

FROST'S VARIETY SELF-CENTERING CHUCK.

We can commend the new chuck represented in the annexed engraving as one of the best that we have ever seen. It embodies a mechanical construction which enables the implement to hold tools of any form of shank; it is perfectly self-adjusting, its wearing surfaces are exceedingly large; it has no gearing or multiplicity of parts; and the way in which the four simple proportions are made to answer all the various requirements strikes us as a remarkable exhibition of inventive ingenuity.

The chuck consists, first, of the outer casing or collar, Fig. 1. In this there is an aperture which receives the screw,

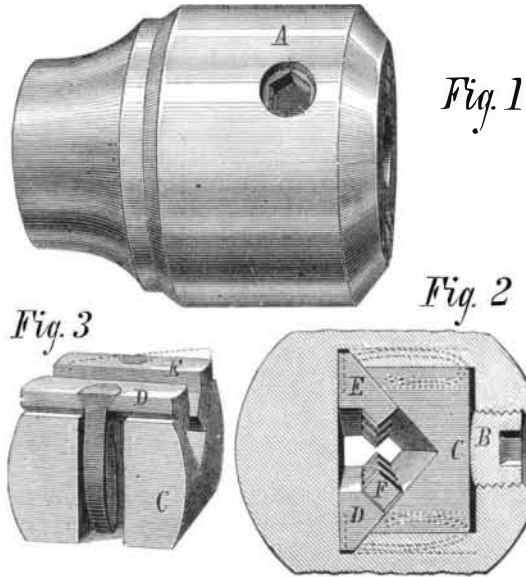

B, Fig. 2. Said screw has a square recess in its head, and is turned by an ordinary key. The lower end of the screw bears on the jaw, C, Fig. 3. The under face of this jaw is V-shaped. In each of its sides is a recess to accommodate the bent springs, which are attached to the jaws, D and E. These jaws bear flat against against the case, and, by their inclined sides, bear also against the V of jaw, C. They are provided with projections at F.

From Fig. 2 it will be evident that, if the jaw, C, is pressed down, its inclined faces, acting on the upper inclined sides of jaws, D and E, will force said jaws together, and as contact becomes closer, the projections, F, on the latter will interlock. The square-shanked tool will then be held on two sides in the V of the jaw, C, and on the other sides by the proximate parts of jaws, D and E; and the tool will be the more tightly held as the screw, B, is turned down. When the screw is relaxed and the tool removed, the springs on jaws, D and E, will expand, and the jaws will thus be carried back to their former places. It will be observed that these springs have no actual duty to perform. There is no strain upon them, and their only office is to draw the two light pans back again into place.

Now if a tapered tool be inserted, in order to fit its shank, the two moving jaws, D and E, must assume an angular position. This they can easily do, because their springs are single and attached to them directly at the middle of their length, so that they can pivot on the springs. Also the upper jaw rolls on the screw end; and there is abundant space between its top and the casing to allow of considerable angular movement. Its front sides, as shown in Fig. 3, are curved,

Fig. 4.

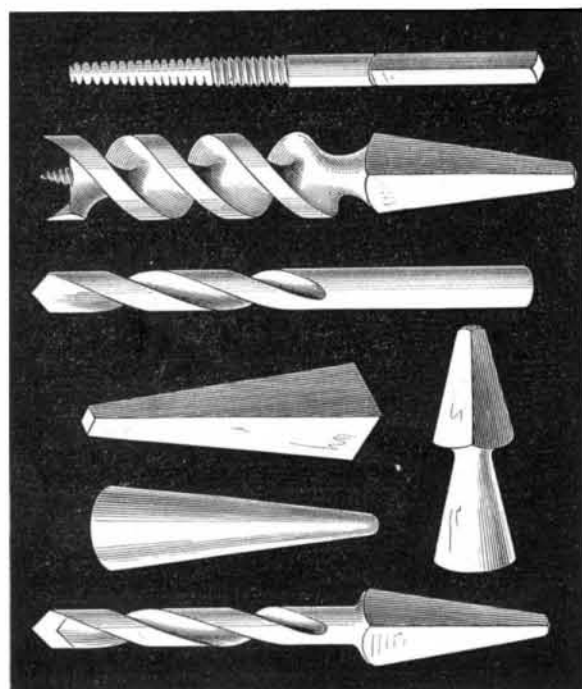

so that this radial or balancing movement does not alter the length of the aperture which it aids in forming. The device is one of those which, although comprehensible at a glance, is difficult to explain; but the shape of the tapered orifice formed will, we think, readily be understood from Fig. 2. As the jaws adjust themselves, being perfectly free to adapt their movement to any shaped object placed between them, it is no longer material that tools be provided with a uni-

form shank. In Fig. 4, we have represented a variety of forms covering those in common use. These we have tested in the chuck, and it holds them all with equal facility, accurately, and in true center.

For further particulars address the inventor, Mr. William Frost, 53 Dartmouth street, New Bedford, Mass.

Application of Electricity in Dyeing.

According to the *Bulletin de la Société Industrielle de Mulhouse*, Goppelsroeder has observed that if an electric current is passed through aniline dye becks decoloration ensues, with formation of colorless salts of lenkaniline. If yarns or cloths are steeped in the liquid they absorb it, and on subsequent exposure to the air they become colored, just like the goods drawn out of an indigo vat and exposed to the air. The colors thus obtained are said to be faster than those produced by the ordinary method. Whether this principle of dyeing will prove practically useful remains to be seen.

A NEW METHOD OF SECRET WRITING.

The annexed engraving represents a simple device for purposes of secret writing, by means of which may be prepared communications intelligible only to persons having a similar apparatus, and impossible to be deciphered by any one else. The device is simply a sheet of metal upon which the alphabet is written in two parallel rows, and beneath each letter an opening is made. The plate is inclosed in a suitable frame. It will be seen at once that, if this apparatus is laid over paper, and dots made on the latter through the apertures—under A, B, C, for example—the marks when the paper is removed will have no signification. If, however, the recipient of the communication should place over the paper an apparatus of precisely similar construction, then the dots would of course show through the apertures under A, B, C; and he would know that those letters formed the message. It will readily be seen how words can be indicated in this way. In cases where letters are placed in inverse order, a small inclined line is drawn through one of the side slots in the frame. This indicates the mode in which the letters should be read. Double letters are indicated by vertical lines in place of a simple dot, and words are separated by a horizontal dash. The invention seems excellently

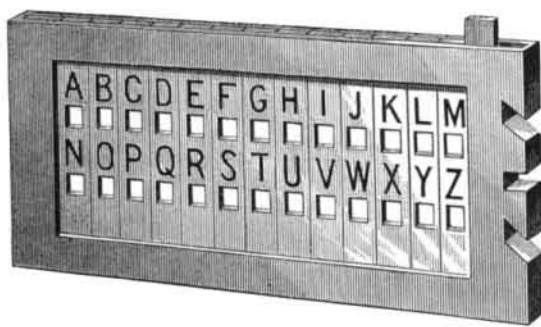

adapted to the purpose, and might preferably be used in lieu of cipher codes.

Patented December 26, 1876. For further particulars, address the inventor, Rev. Alexander Berghold, New Ulm, Brown county, Minn.

Captain Burton's Discoveries in the Land of Midian.

A correspondent of the *London Times*, writing from Alexandria, informs the public that Captain Burton, the African traveler, has made a "find" of unusual interest. At the request of the Khedive he has visited the land of Midian, the desolate region on the eastern side of the Gulf of Akabah, the easternmost of the two long and narrow estuaries in which the Red Sea ends.

Accompanied by M. George Marie, a French engineer, Captain Burton landed in Midian on 2d April, and in an exploration of some weeks explored a region full of ruined towns, built of solid masonry, with made roads, aqueducts five miles long, artificial lakes and massive fortresses, all marking a wealthy and powerful people. Their wealth was based on mining operations, and Captain Burton reports the existence of gold, silver, tin, antimony, and turquoise mines. The auriferous region is extensive; indeed, the discoverer believes he has opened up a California, and the Khedive proposes to have the country worked by European capitalists.

It will be remembered that in the Bible, Midian is always described as a land full of metals, especially gold, silver, and lead. It is more than probable that Solomon's Ophir was situated there, as the small ships in which he imported gold, ivory, and peacocks were launched at the head of the Red Sea. Midian is part of the Egyptian Viceroyalty.—*London Spectator*.

IMPROVED BALLASTING TUBE FOR VESSELS.

The invention illustrated herewith consists in providing vessels with a series of pipes extending from their bottoms to the depth of about thirty feet. The pipes are telescopically constructed, so that they may be easily lowered below or raised up within the hull of the vessel. The inventor claims that this device, as it enables the ship's center of gravity to be lowered, will prevent vessels rolling or capsizing, check their leeway, and obviate the use of ballast or drags.

The construction of the tubing is shown in Fig. 1. Fig. 2

exhibits its application to the vessel. A large pipe, A, extends upward from the keel to the spar deck and serves as a well. Through a suitably packed collar in the lower portion passes a second tube, B; and through the latter, a third tube, C, in the bottom of which is a valve, held down by a spring which yields and allows the valve to open when the tubes descend, so that they may become filled with water. A chain, attached as shown to tubes, C, serves to raise and

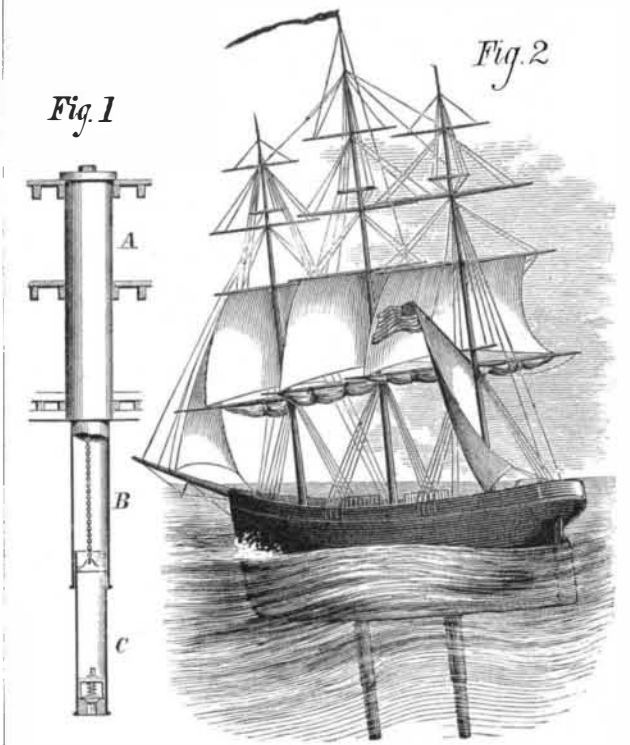

lower the device as desired. The tubes may be arranged to pass directly through the keel, or they may be disposed on each side of the same.

Patented April 10, 1877. For further particulars, address the inventor, Rev. Alexander Berghold, New Ulm, Brown county, Minn.

IMPROVED GAUGE.

Mr. Benjamin F. Stoner, of Rockford, Ill., has patented through the Scientific American Patent Agency, May 1, 1877, an improved instrument, which may be used as a gauge for all irregular surfaces and for work which an ordinary gauge cannot reach. It may also be used as a marking gauge, as a try square, and as a trammel.

A represents the head, which is rectangular in form, and may be plated with metal to prevent wear, and which receives the rod, B. The latter is secured in place adjustably by a set screw, a'. C is the pivot finger of the trammel, which is made with a globe socket upon its base to receive the rod, B, and is secured adjustably upon said rod by a set screw, c'. D is the marking needle, which is passed through a hole in the rod, B, near its outer end, and is secured in place adjustably by a set screw, d', passing in through the end of the said rod, B. The needle, D, may be made short, as shown in Fig. 1, for convenience in using the instrument as an ordinary

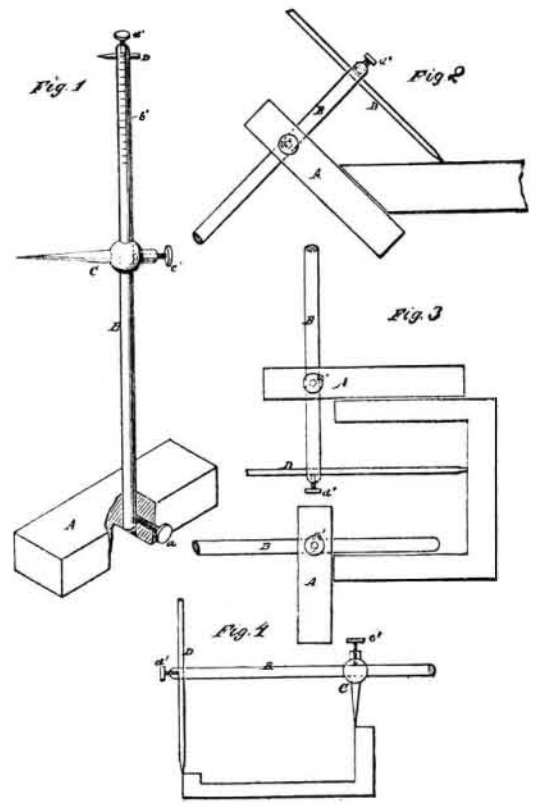

marking gauge, or long, as shown in Figs. 2, 3, and 4, to adapt it for use for gauging irregular surfaces, and for use as a trammel. Upon the rod, B, is formed a scale, e, of division marks. When the instrument is to be used as a square, the rod, B, can be adjusted to any desired length, and can be used where the blade of an ordinary square would render it inconvenient to use it, or prevent its use.