

NEW FEATHERING PADDLE WHEEL.

Mr. Henry Williams, of Milwaukee, Wis., has patented through the Scientific American Patent Agency, April 3, 1877, a new paddle wheel in which the paddles or floats are feathered in passing into and out of the water. As shown in the engravings, the wheel carries a number of journaled radial arms, *b*, having at their outer extremities paddles or floats, *B*, which are turned through a quarter of a revolution by T levers, *c*, attached to the inner ends of radial arms, which carry a friction roller, *e*, at each end. These friction rollers move in a cam, *C*, of peculiar construction, which turns the T levers, and consequently the floats or paddles, at the proper instant.

The feathering part of the cam, *C*, is placed so that the paddles are turned at right angles to the plane of rotation as they enter the water, but are turned edgewise or parallel to the plane of rotation before they begin to rise in the water.

The Scientific American.

"THE SCIENTIFIC AMERICAN for last week contains some excellent illustrations of the great engineering work of the Delaware, Lackawanna, and Western Railroad in tunneling Bergen Hill, also a description of its progress and the expense of constructing this great addition to the railroad interests of our State, together with many other matters of interest. Mechanics and artisans, and indeed professional men generally, who desire to keep well posted in the science of mechanics, and thus attain greater usefulness in their respective professions, can make no better investment of a few dollars than by subscribing to so valuable a periodical as the SCIENTIFIC AMERICAN."—*Somerset (N. J.) Gazette.*

WILKINSON'S IMPROVED LIQUID MEASURE.

We illustrate herewith a convenient apparatus for grocers' use, designed for drawing kerosene oil in the store directly from the barrel in the cellar. It is so made that the hands need not come in contact with the oil; and it saves the time of traveling to and from the cellar whenever oil is to be drawn. At the same time, it affords an accurate means of measuring out the liquid, even to the smallest quantities; and it prevents evaporation of the same, and also chance contact with fire during handling.

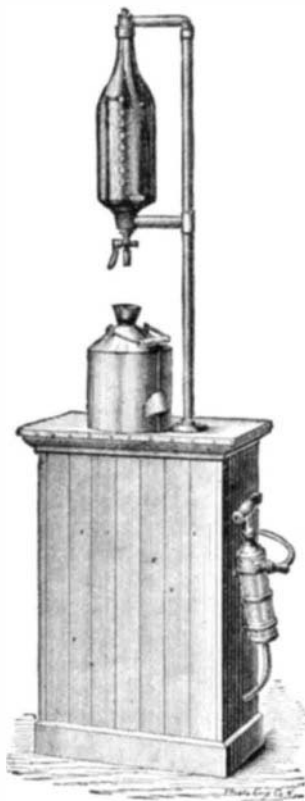

The device consists of a pump, shown beside the stand in the engraving, which is connected to the oil cask by a tube which extends upward and communicates with the upper portion of a glass measure, which is marked with a graduated scale to represent gills, pints, quarts, etc. The construction is such that, when the stopcock is opened to draw off the fluid, a valve is also opened, and air is admitted to the top of the receptacle. When the measure is being filled by pumping the fluid into it, the air will open the upper valve and escape, the valve afterwards closing and preventing evaporation. The apparatus is made in any desired size and with any graduation.

Patented June 13, 1876, by Mr. J. W. Wilkinson. For further particulars, address the manufacturer, Mr. H. J. Appleby, 911 Market street, Meadville, Pa.

Science in Mexico.

We are indebted to the Hon. C. Vincente Riva Palacio, Minister of Fomento, of the Republic of Mexico, for a copy of the first volume of the *Anales* of that department. It is a very handsomely printed document of 208 pages. President Diaz has directed the publication, under the above title, of such scientific matters as the Minister may deem to be of public interest.

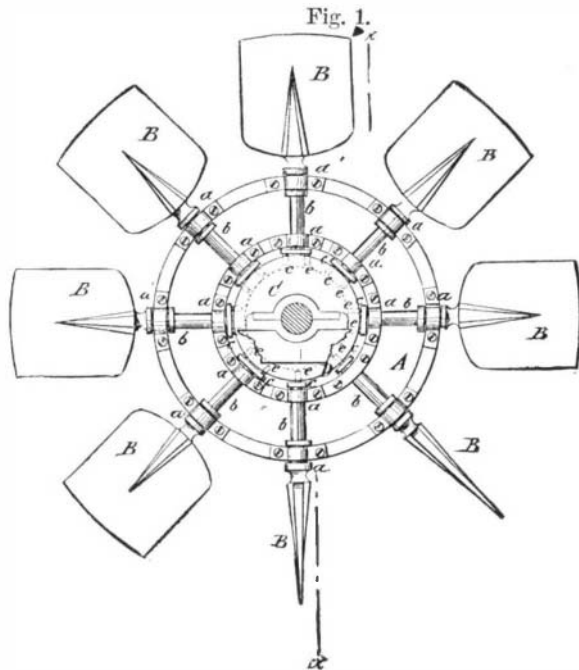

WILLIAMS' FEATHERING PADDLE WHEEL.

It would appear from this publication that President Diaz is a zealous friend of Science, and that he is disposed to do all within his power to advance the cause of scientific progress in Mexico. One of his earliest proclamations was in relation to the formation of a national astronomical observatory. The elegant palace of Chapultepec has been permanently dedicated to this purpose. A meteorological and magnetic observatory has also been provided for on the same premises. The plans for construction are practical and effective. The situation is one of the finest in the world for an observatory. Excellent lithographic plans of the projected new observatories are given, also a telegraphic map, with an account of the Mexican system of telegraphs, about eight thousand miles in extent, worked chiefly by the government. President Diaz also recently ordered a survey for a new branch canal, to facilitate the transportation of produce from the narrow country near Mexico to the railway, and Mr. Edward Davis, C.E., has surveyed an effective and economical route therefor.

Some very interesting information is given concerning the earthquakes of Jalisco, with particulars of the volcano of Ceboruco, which latter has been in a state of constant eruption since 1870. The members of the Scientific Commission established themselves for two weeks at the rancho of Uzeta, 2,000 feet distant from an approaching bank or stream of lava; and here, during day and night, they instituted observations and made surveys. With incredible difficulty they succeeded in ascending the volcanic peak and looking down into the crater, which was divided into three mouths, one of which belched forth flames and stones every eight minutes; the others poured out smoke and ashes; while two lateral streams of lava slowly flowed out sideways from below the peak. The concluding chapter relates to the Mexican department of the Philadelphia Exhibition, gives the names of Mexican exhibitors, etc.

Value of the Scientific American.

"THE SCIENTIFIC AMERICAN, published by Munn & Co., of New York, is without a rival as a scientific paper, and to the mechanic is simply invaluable. We honestly believe any mechanic would derive information from a year's reading of the SCIENTIFIC AMERICAN which any amount of money could not buy. Some of our enterprising mechanic citizens, we hope, will try the experiment of reading this really valuable and practical journal one year. We know they would never give it up."

[Notices similar to the above (from the Glasgow Weekly Times) often meet our eyes in looking over our exchanges. We thank our contemporaries for their good opinion of the SCIENTIFIC AMERICAN, and wonder why the class of persons referred to above do not all subscribe and gain the benefit which they are assured would be theirs.—Eds.]

Electrical Treatment of Wounds.

M. Onimus has lately observed that the suppuration of wounds or ulcers may, by means of continuous electric currents, be increased or diminished, according to the direction of the current. The descending current, that is, when the positive pole is placed near the nerve center and the negative at the periphery, increases the suppuration, but, at the same time, the phenomena of nutrition are more considerable, and the fleshy pimples are formed with great rapidity. On the other hand, with the ascending current, the suppuration disappears very quickly. A small crust forms on the wound, which is difficult to remove, and under it there is a cicatrization.

IMPROVED MACHINE FOR SHAPING SPRINGS.

Mr. E. C. Lewis, of Auburn, N. Y., has patented through the Scientific American Patent Agency, March 27, 1877, a novel machine, which we illustrate herewith in plan and section, for automatically shaping or fitting springs in perfect and quick manner, by any unskilled workman, so as to supersede the present imperfect method of pinching the heated spring leaves or plates into form by means of tongs.

A represents a solid former, and A' a flexible former, which are both supported on a bed plate, *B*, the solid former being secured thereto by a screw bolt, *B'*. The bed plate, *B*, rests on suitable supporting standards, *C*, which carry at one side an upright arm or post, *a*, with screw cam or knuckle device, *E*, and at the opposite side posts, *b*, to which a solid drop, *F*, with handle, *F'*, to operate the same, is hinged, and supported in upright position by an arm, *F''*, of the bed plate. The drop block serves to straighten the edges of the plates in conjunction with the bed plate, while they are shaped by the formers. The solid former, *A*, may be interchanged for the purpose of shaping springs of different sizes, while the flexible former, *A'*, is adapted to fit any size and shape of springs. The flexible former is constructed of a number of steel lugs, *d*, which are riveted to a band, *e*; or when the shaping machine is made in larger size, the lugs are connected in such a manner as to form a continuous chain, each lug forming a link. A second band, *f*, bears on the back of the first band, or directly on

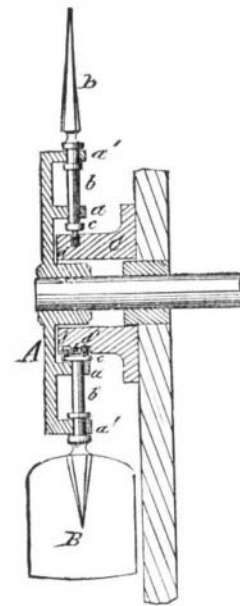

the connecting links of the lugs, and is attached at the ends to a rigid bow-shaped bar, *G*, to the center part of which a compressing screw bolt is applied. The lugs are channeled along the center, the channels running in the direction of the longitudinal axis of the former. The object of the channels is to produce the instant chilling of the edges of the

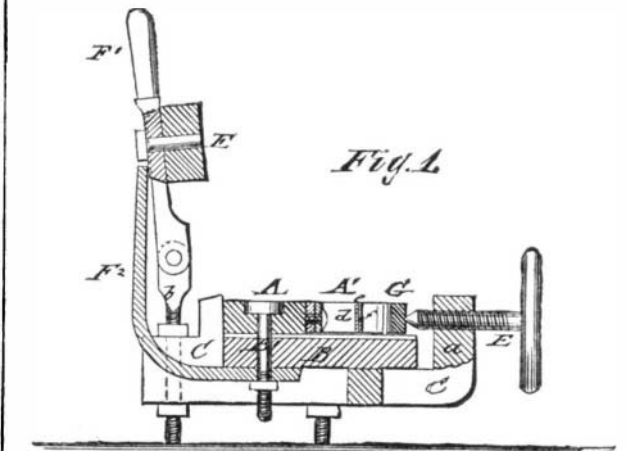

leaves or plates, while leaving them slightly warm at the center to draw down the temper somewhat. The heated plates are placed on a center pin of the solid former, and then exposed to the action of the cold formers, which are

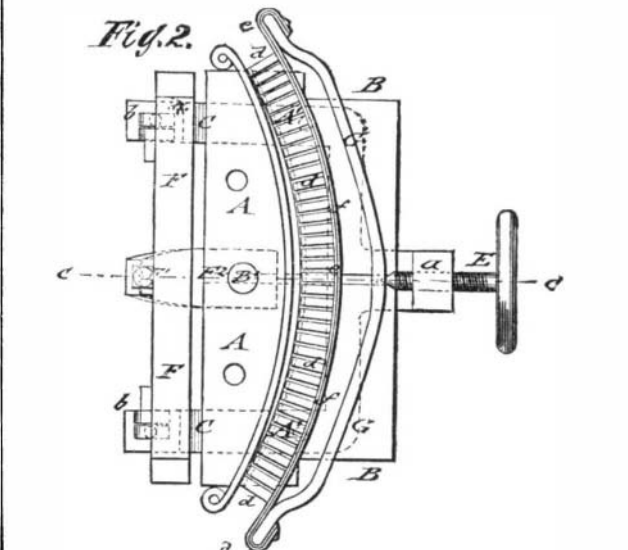

strongly pressed together by the screw, so as to shape, chill, and temper the hot plate. The plates, when taken from the shaping machine, are ready to be bolted, and require no further manipulation.

PROFESSOR TAYLOR, of Chicago, accompanied by Lieutenant Wood, U.S.A., with all the instruments for scientific exploration, recently left Victoria, B. C., for Sitka, to make a survey of the famous snow peak, Mount St. Elias, and ascertain its altitude. It is situated 350 miles north of Sitka, and has never been ascended yet, and its height has not been determined. The result of the exploration will be reported by the department at Washington.