

**A SCREW SNOW PLOW.**

Mr. Robert G. Little, of Halifax, Nova Scotia, is the inventor of the novel snow plow herewith illustrated, which was patented through the Scientific American Patent Agency, January 30, 1877. The new feature is the screw fan, A, projecting in advance of the plow on a horizontal shaft, which assists in throwing the snow off at and back along the sides of the plow. On each side of the plow there are fans, D, to receive the snow from the front and project it off at the sides, said fans being turned by a shaft arranged transversely of the machine. The side fan shaft is geared by countershafts with the front axle of the plow. If preferred, an engine may be mounted in the cabin of the plow specially for driving the fans, steam being furnished to it from the boiler. K and L are cutters attached to the plow for cutting the snow when packed hard.

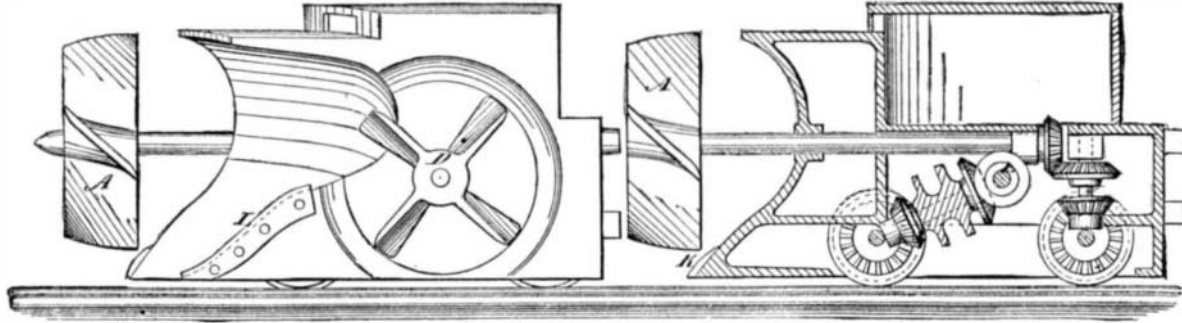

LITTLE'S SNOW PLOW.

**PHOTOGRAPHER'S RETOUCHING DESK.**

This is a desk for artists' use, which enables the retoucher to see perfectly his work, get at it with ease and facility, and continue working with precision and comfort, and it must materially tend to excellence in result. It is the invention of Messrs. Burrows & Colton, and is manifestly the outcome of experience, the invention of one who has felt what was wanted. The engraving will give an idea of the general arrangement.

The retoucher may as easily sit upright to the work as in a leaning, round-shoulder-inducing position. The base contains a drawer for holding loose portions of the desk, pencils, etc., and is provided with a pencil sharpener in a handy position. The desk proper can be placed at any suitable angle. It is provided with a circular revolving inner frame, with clamping screws, sliding in a groove to permit them to hold firmly negatives of various sizes. Behind a central aperture in this revolving table or stage is an attachment on the principle of a series of revolving diaphragms, containing three apertures, any one of which can, on revolving the disk in which they are contained, be brought immediately behind the aperture in the desk, over which the negative rests during retouching. This affords facility for modifying the lighting through the negative. In this revolving disk, in each of the three apertures, is a different kind of glass—one plain, clear glass, one fine ground glass, and one opal glass. This arrangement enables the manipulator to judge with ac-



curacy as to the effect of his work on the negative, and guides him in modifying the amount or style of the work he is applying. Placed underneath the desk is a concave silvered reflector, for throwing up a satisfactory light on the negative; this is of great value, either for daylight or artificial light. As the circular table or stage in the desk readily revolves, the artist is enabled to bring the negative in a moment into a satisfactory position for working on. By no means the least important adjunct to this desk, says the *British Journal of Photography*, is the magnifying glass, attached to a steady, movable arm of brass, with adjustment to place it in any position and at any focus to suit the artist. The importance of steadiness in the position of the magnifier cannot be over-estimated in saving the eyes of the workman.

**A Large Snake at the Zoo.**

That enthusiastic naturalist and writer, Frank Buckland, describes (in *Land and Water*) the recent arrival in London of an anaconda from South America. He says:

"This immense snake is now safely housed in the snake house in the Zoological Gardens, under the parental care of Holland, who has for many years so ably managed the snakes, poisonous and non-poisonous. Our visitor arrived at Liverpool in a large box. Intelligence was given to Mr. Bartlett, who proceeded to Liverpool to inspect him, a matter of considerable difficulty. It will not do to buy an expensive snake of this kind without a warranty. Snakes are very liable to canker in the mouth. The gums get swollen and flabby, and completely conceal the teeth, so that the beast cannot feed. Again, if snakes are injured in the capture, they frequently die in consequence. It was necessary to

examine the snake as to these two points. Having been shut up for several months without food, and in the dark, the anaconda was not in a good temper. When the lid was opened Mr. Bartlett caught him tight round the neck with both hands; it was not necessary to open the mouth, as the savage snake did that soon enough of himself, in true anger. A moment's inspection showed he had no disease of the

gums. It was with some difficulty that Mr. Bartlett got his head back into the box, without letting out more than a foot or two of his body. The anaconda has not poisonous teeth, but has great and dangerous powers of crushing. The box with the snake weighed over 2 cwt. It was with much dodging that Anaconda was conducted by two keepers to his new quarters, where he at once retreated into a bath of warm water, from which as yet he has only emerged once or twice. It is difficult to give the exact length of the snake, as he is not to be measured with as much facility as a fathom of rope. He is now lying in three parallel folds in his bath; we know the length of the bath, and we calculate his length to be between eighteen and twenty feet—a tremendous fellow! It was impossible to get a tape measure round him; but having measured his diameter in his thickest part, we conclude that he is over two feet round the body. At present he is thin, and his skin fits him very loosely. It is hoped that he will soon begin to feed. Mr. Bartlett, with his usual ingenuity, has found out how to make Mr. Anaconda feed. He covers his bath over at night, and puts therein with the snake a duck. The duck is always gone in the morning, and the snake appears fatter. Anaconda is decidedly nocturnal and aquatic in his habits. Like our own British snake, it is found in marshy, damp places, and he feeds upon animals which come down to drink at night. Mr. Bartlett has ascertained that the last meal of this snake had consisted of a young peccary, the horny part of the hoofs having been discovered in the stones at the bottom of the cage; there are also the hairs of another animal, which has to be diagnosed by microscopists. This tropical American snake is also called the *aboma*. The provincial name is *el traga venado*, or the deer swallower. He never interferes with men, although of course he will take his own part if attacked. It is greatly to be hoped that this magnificent snake will in time get an appetite and recover from his travel-worn appearance. His color may be described as buff, with very dark markings on the upper parts. His companion in the cage is a magnificent reticulated python (*ular sawa*), caught at Penang. He has been at the gardens since August, 1876, and has not eaten anything since he arrived. He shed his skin recently, and is now most lovely to behold. It would be impossible to describe the tints of the new skin (a splendid lacing of bronze, blue, gold, and black), except by saying that they are quite as gorgeous as a peacock's plumage.

"I have had some snake skins tanned, a lady having promised to wear a dress ornamented with them. Eve dressed in snake skins is too good a point to be overlooked."

**A Fountain on a Spire.**

The Virginia (Nev.) *Enterprise* of March 6 says: "Last evening, about 4 o'clock, the eyes of hundreds of persons on the streets were directed towards the top of the spire of the new Catholic church, where was seen a fountain spouting numerous jets high in the air. A large iron pipe is carried up through the steeple and up the large cross surmounting the same. The pipe then takes the form of the cross, behind which it is hidden, and from holes perforated at proper intervals the jets are sent up. From the top of the cross and from the end of each arm large streams ascend to the height of about 25 feet, and between these are thrown up a great number of smaller jets. The height of the top of the cross from the ground is 170 feet, and last evening, the air being calm, the numerous jets spread out in the shape of a fan. The rays of the declining sun fell upon the jets and spray at just the proper angle to light up and bring out the whole in a beautiful roseate glow which surrounded the top of the cross like a glory. This novel fountain was not constructed for mere ornament. It is intended for use, in case of the breaking out of a large fire, as a protection to the spire and roof of the church. It is but the work of a moment to turn on the water and drench the spire. The height to which the water is thrown above the cross shows the great force of the water works of the city."

Now is the time to purify your chicken houses to prevent disease. Burning sulphur in the houses; sprinkling with carbolic acid; whitewashing with hot lime; cleaning out frequently; providing new nests; providing liberally, ashes, charcoal, burnt oyster shells, lime, gravel, pure water, will all aid in stopping or warding off disease.

**How to Photograph Microscopic Objects.**

Dr. Fayel lately presented to the Academy of Sciences, Paris, the details of a new method of micro-photography. He placed upon a window sill the microscope he employs for the purpose, which had over the top a small wooden box supported on a tripod. This wooden box is the camera, which can be fitted and removed at pleasure, and has a plano-convex lens inside the camera, moved by a screw. By calculation the author had determined, first of all, and noted upon the exterior, the different heights that the camera, should occupy, in order to secure enlargements with the various powers employed, the image refracted by the lens being projected upon the focussing screen of the camera of the same size exactly as it is seen with the eye. Matters thus regulated, M. Fayel takes the microscopical preparation

it is desired to enlarge, and reproduces and examines it under the microscope; and when the latter has been properly focussed, the camera is put in its place, without touching either the microscope or the preparation, the eyepiece remaining in its place. He brings the lens down to the point corresponding to the scale referred to above, and, without even taking the trouble to look at the image upon the ground glass, he forthwith proceeds to put a sensitive plate into the apparatus. When the exposure is at an end, the *cliché* is developed in the ordinary way. The advantages claimed by Dr. Fayel for this mode of operating are the following: 1. It furnishes to the physiologist the possibility of taking a photographic image of any object visible under the microscope, no matter to what scale it is enlarged. 2. It permits the production of an image without touching the microscope or the object or preparation under it—there is no need even to focus after the camera has been adjusted, because this is done automatically, and always remains the same. 3. It yields an image of the dimensions precisely of that seen through the eyepiece; and, finally, it allows one to transfer to a competent operator all the photographic labors connected with the affair. The micro-photographs presented to the Academy of Sciences as the fruits of this apparatus were of a most interesting and remarkable character.

**A NEW SODA-CARBONATING APPARATUS.**

James McCloskey, of East Cambridge, Mass., has patented through the Scientific American Patent Agency, January 30, 1877, a new apparatus for carbonating soda, which we illus-

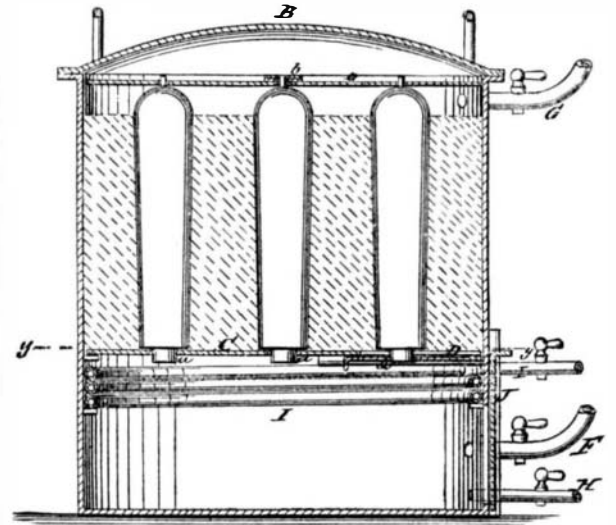

trate herewith. It consists of a chamber, A, having a horizontal perforated partition, C, near its base, and a number of removable shouldered pins, E, that rest in the perforations of the partition, and are removed when the chamber is filled with soda ash, leaving corresponding openings in the contents of the chamber. F and G are gas pipes, and H is a steam pipe, for introducing steam into the chamber for facilitating the process of carbonizing. I is a coil of steam pipe for heating and drying the soda, should it become too moist to grind.

The manner of using the apparatus is as follows: The cover being removed, and the pins, E, being in their places, chamber A is filled up to the rounded portion of the pins, E, with soda ash. The pins are then removed, leaving openings through the soda ash above the perforations in the partition. The cover, B, is placed and sealed, and carbonic acid is introduced through either or both of the pipes, F G, and more or less steam is also admitted through the pipe, H. The openings left by removing the pins, E, expose a great amount of surface to the action of the gas; hence the process is facilitated.

The advantages claimed for the apparatus are that, with it the process is completed in much less time than by the ordinary method, and the discoloration commonly produced by the wooden trays is entirely obviated.

**BODY COPAL VARNISH FOR COACHMAKERS' USE.**—Fuse 8 lbs. fine African gum copal, add 2 gallons clarified oil, boil slowly until quite stringy, mix with 3½ gallons turpentine, and strain. The boiling will take 4 or 5 hours.