

IMPROVED SELF-DISCHARGING COAL HOD.

We illustrate herewith an improvement in coal hods, designed to facilitate the discharge of coal into the stove, and to obviate the clumsy and awkward exertion with which every one is familiar. A rock shaft, B, is journaled in bearing plates, D, below the bottom of the hod, and is provided with a handle, E, in the rear and a crank in front. This crank is connected through the rod, C, with an eye, F, which latter passes through a narrow slot in the hod, and is riveted to a sliding shovel, A. By tilting the hod and twisting or rocking the shaft, B, to and fro, as in Fig. 1, the shovel, A, slides back and forth under the coal, and discharges it smoothly and uniformly into the stove without spilling. The additional cost to a hod is but trifling, as all the parts necessary to fit up an ordinary hod are shown in Fig. 3, namely, a shovel, A, formed of one half pound of No. 17 sheet iron, and one half pound of malleable iron castings, B C D E F, costing in all about ten cents. The invention is a cheap, simple, useful, and apparently practical one. It adds but imperceptibly to the weight of a hod, and does not interfere with the holding capacity of the same. It is attachable to any of the hods in use, and does not destroy the utility of the hod even if the devices become broken. It avoids battering the end of the hod, and dispenses with the rear handle. It does not soil the hands while operating the hod, and its attachment to the hod involves no change in the shape of the latter which would prejudice its popularity.

Patented through the Scientific American Patent Agency, February 9, 1875, and March 16, 1875, by Edward W. Byrn, 309 C street, N. W., Washington, D. C. Correspondence is solicited with manufacturers with a view to effecting a sale or manufacturing on royalty.

IMPROVED WRENCH.

Mr. Wilbur J. Squire, of East Haddam, Conn., has patented (March 14, 1876) through the Scientific American Patent Agency, a novel form of wrench, engravings of which are given herewith. The jaw head, A, is constructed with a circular base, B, and a circular groove, C, on each side, also with pin holes, D, in the base. The handle is made in two parts longitudinally, which are grooved to receive the base and have a curved flange, E, to fit in the grooves of the head and secure it when the parts are fastened by screws, F. The parts of the handle are also grooved to receive the stop pin, G, and the spring, H, which are used for fastening the jaw head. These are notched to let the thumb studs, I, project sufficiently to pull the pin back for releasing the jaws. The latter are dovetailed on the inclined forks, L, of the head, to slide forward and backward so as

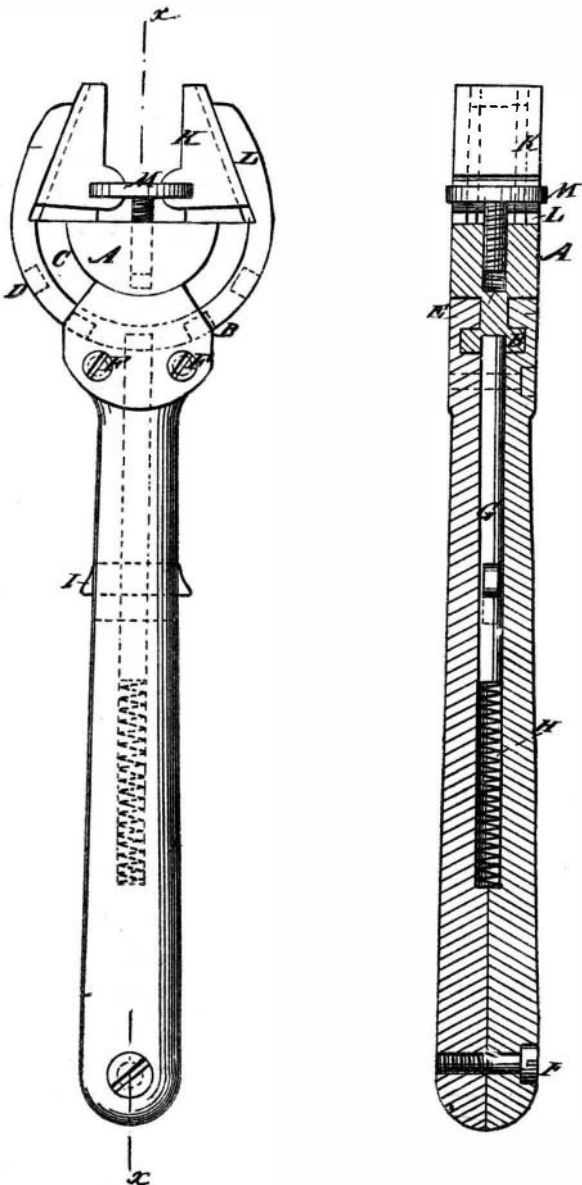

to be adjustable for different sized nuts. The disk-headed screw, M, is notched in the jaws and screwed in the head so as to work the jaws backward and forward.

Injections of Carbolic Acid in Rheumatism.

Injections of carbolic acid have been used with benefit to relieve the pain of acute rheumatism, by a hospital surgeon, Dr. A. Scharpringer. The method is similar to that practised at St. Francis' Hospital, and consists in using an aqueous solution, containing from three to five per cent of the acid. About twenty minims of this solution are used at each injection in the neighborhood of the affected joint, and the results, though not permanent, are sufficient to relieve the patient temporarily. In regard to this species of medication an important question arises, and it is this: Does the relief come from the water of the solution, or from the contained acid? When it is remembered that a large

ened or spread. To bend the shoe, the long jaw, C, is placed within the shoe, with the end of the arm, D, resting against the arm of the shoe to be drawn inward or bent, and with the short jaw, E, resting against the outer corner of the heel of the said arm of the shoe. Then, by moving the handles toward the heel of the other arm of the shoe, the said shoe will be bent or contracted.

Water Melons.

Mr. George R. McKee, of Georgia, writes as follows: "We do not market more than one third of the melons that we can produce, the balance being virtually wasted. It is with a view to utilizing this wasted crop that I request the subject continued."

To this, the *Maryland Farmer* replies: "There has been so little done in this direction, and so little experience had, that we can only give our own operations. We peeled off the rind, took out the seeds, and then crushed the melons in a cider press, squeezing out the juice; then boiled and evaporated it, in the same way as we do the sap of maple or the juice of the sorghum, and each operator will know when he has boiled it to the consistence or thickness desired; and then it should be stirred in shallow pans—like milk pans—over a gentle heat, until it becomes granulated, or "sugared off," as they say in the maple sugar works, when sirup is converted to sugar.

"We can give our readers another useful hint for utilizing their surplus water melons. It is this: Last year we saw some Virginia farmers feed water melons to their milch cows, when they came up at night, with very good effect, by increasing the quantity and improving the quality of their milk. In other instances we have seen the good results of feeding cows sound water melons; after standing in the stall or yard over night, they eat melons with avidity in the morning."

NEW METHOD OF MOLDING CYLINDERS.

The method ordinarily employed for hardening the surface of cast iron cylinders consists in casting them in iron molds with thick sides. Besides possessing a large number of other disadvantages, this system does not allow of deep tempering, since the mold itself heats very rapidly and does not serve to cool the cylinder cast in it. The method devised by M. A. Tuck, of Donawitz, Austria, says the *Bulletin du Musée*, and in which water is employed to cool the cylinder, allows of continuing the cooling process as long as is desired, and of carrying the temper as far into the interior of the cylinder as the same is generally possible by outside refrigeration.

This result is obtained by a circulation of water outside the mold. The shell, f f, or rather the part of the same which surrounds the body, a, of the cylinder to be tempered, has double sides, so as to receive the water; the trunnions, b, have single sides. The interior envelope, that is to say, the real mold, f is of thick boiler plate. Its joints are welded, and it is provided with strong welded rings of wrought iron. This mold is placed vertically and surrounded by a cylindrical cover of wood, g, the heads of which are made watertight. As shown in the engraving, the tube, i, leads the water into the lower part of the mold, and the water enters by the openings, h, becomes heated, rises, circulating between the envelope, f, and the wooden wrapper, and leaves by the tube, k, at the upper portion. The trunnions, b and c, of the cylinder, which are not to be tempered, are cast in molds, e and d, and in earth, placed with great care so as to prevent any possible contact of the molten iron with the

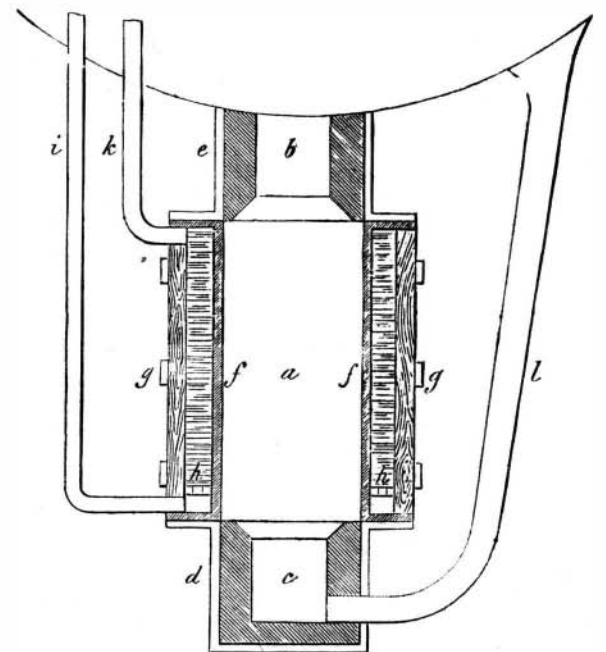

water. The molten metal is conducted in the ordinary manner by a conduit, l, which terminates at the lower portion of the lower trunnion, e. In the same way as the cooling can be regulated by the length of the water circulation, so can its intensity be varied by regulating the temperature of the water used.

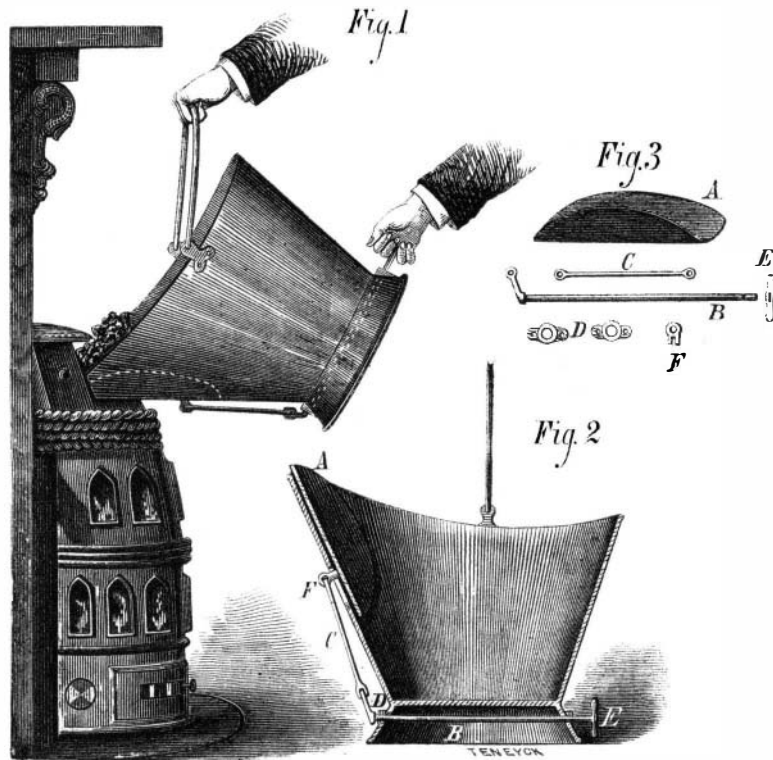

BYRN'S SELF-DISCHARGING COAL HOD.

number of cases have been reported in which water alone proved sufficient to relieve paroxysms of pain for a short time, it would seem that our knowledge of the effects of hypodermic medication is by no means complete, and that further observations are necessary in this direction.—*New York Medical Journal*.

IMPROVED TOOL FOR BENDING HORSESHOES.

Mr. William Ray, of Poplar Post, Ohio, has invented a tool for straightening and bending horseshoes, of which Fig. 1 is a side view, shown in position for straightening a shoe. Fig. 2 is a side view of the same, shown in position for bending a shoe. A and B are the two handles of the tool, which are pivoted together in a manner similar to a pair of pliers. Upon the forward end of the handle, A, is formed a

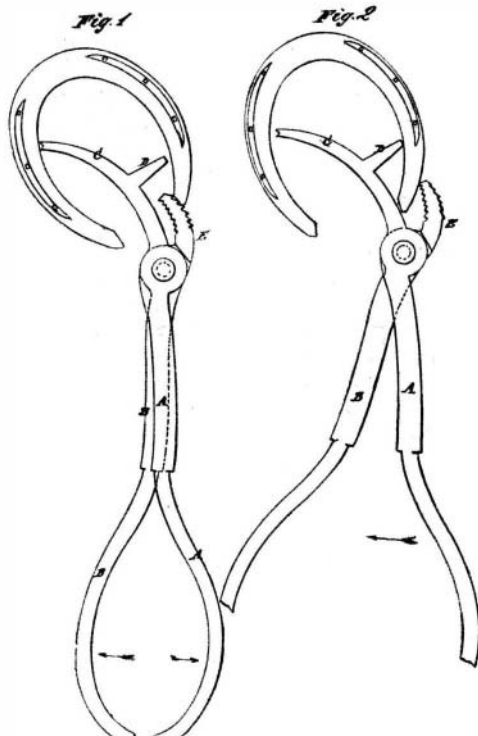

long jaw, C, which is curved outward, and its end is notched to cause it to take a firmer hold upon the edge of the shoe. Upon the middle part of the inner or convex side of the jaw, C, is formed a short arm, D, projecting at right angles, or nearly at right angles, with the jaw, C. Upon the forward end of the other handle, B, is formed a short jaw, E, which is curved inward, and has teeth formed upon both its inner and outer sides, to cause it to take a firmer hold upon the end or heel of the shoe.

In use the tool is placed between the ends of the shoe, with the end of the long jaw, C, resting against the inner edge of the shoe between the first and second nails, or thereabout, and the short jaw, E, resting against the inner corner of the end of the shoe, as shown in Fig. 1. Then, by drawing the handles, A B, apart, the shoe will be straight-