

IMPROVED LOCOMOTIVE AND CAR STEAM BRAKE.

An ingenious brake mechanism has been devised by Mr. T. J. Shellhorn, of Marquette, Mich., and patented through the Scientific American Patent Agency, September 5, 1876. The steam cylinder, A, as shown in the illustration, is placed midway between the driving wheels of a locomotive or the wheels of a car truck. The steam is admitted to the cylinder by a pipe, a, entering midway between the cylinder heads, and acting simultaneously upon two pistons, B, that are arranged symmetrically in the cylinder, and acted upon by volute springs, B', of considerable power. The steam pipe, a, is carried up the boiler head to the steam dome, and the admission and exhaust of steam is controlled by a three-way cock. A drip valve, b, is arranged at the bottom of the cylinder, A. The piston rods are pivoted at their outer ends to brake levers, C, which force the brake heads and shoes, D, against the driving wheels, the leverage being obtained by the fulcrum rods, E; said rods are pivoted to the lower ends of the brake levers, and connected by a sleeve or nut, d, with interior right and left hand screw threads, for the purpose of adjusting the levers, C, from time to time, as required by the gradual wear of the shoes, and also for providing for the distances between the driving and other wheels in different locomotives and cars. The right and left hand sleeve or nut, d, is held in stationary position by jam nuts, d'. The brake heads, D, are fulcrumed at some distance above the fulcrum rods to the brake levers, and further connected to the same at their upper ends by pivoted clearance links, e e. The links, e e, are intended for the purpose of carrying back the brake heads or shoes, with the brake levers, out of the line of friction with the wheels when the brakes are released. The release of the brakes is effected jointly by the exhaustion of the pressure in the cylinder, the action of the volute springs upon the pistons, and the gravitation of the brake heads. The brake levers, C, are not made straight, but with an obtuse angle, and formed by the heel or part below the fulcrum of the brake head with the upper part. By this means the strain of the wheels is thrown upon the top of the axle boxes instead of upon the sides.

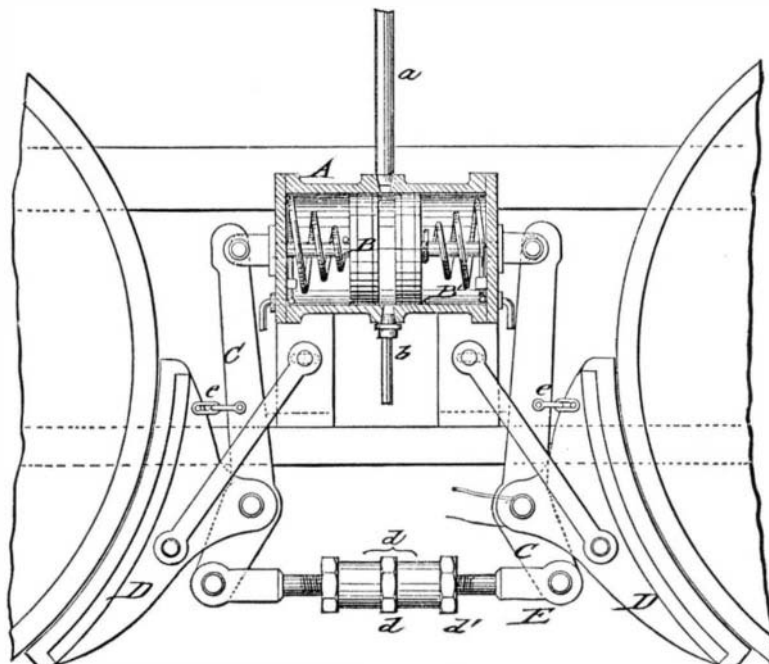

SHELLHORN'S LOCOMOTIVE AND CAR STEAM BRAKE.

IMPROVED NAIL EXTRACTOR.

Mr. William H. Tinker, of Springfield, Mo., has patented through the Scientific American Patent Agency, August 22, 1876, an improved nail extractor, by which the nail is drawn with great facility without being bent, and which is illustrated in the accompanying engraving. B is a sliding handle weight, by which the jaws, C, are driven in the ordinary manner into the wood below the nail, to be then applied to the same by the double foot or leverage of the jaws. The jaws are fulcrumed to the lower part of the handle, and provided with symmetrically extending levers, D, that are opened by spiral springs, C'. The jaws, C, have shoulders, a, in the upper part, that come in contact with the handle or stock, A, and define the position of the levers. The double

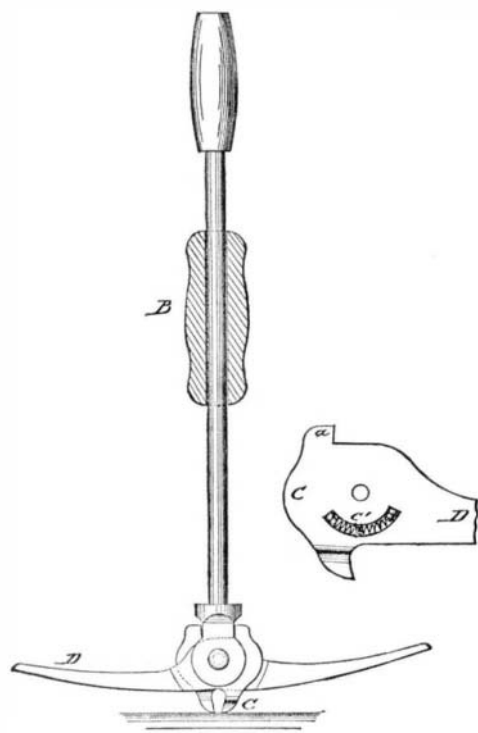

leverage admits the pulling of the nail in two different directions without removing the instrument. This allows the withdrawing of nails from hard or soft wood in an easier manner without bending the nail, as the same may be first loosened and afterward extracted.

Capital and Labor.

Ask any economist, and he will tell you that capital is the accumulation of past labor, intended to move or assist labor, and that it is either a transient or a permanent assistance, the former requiring constant renovation, the latter being of an enduring character. Ask him what labor is, and he will tell you that it is the power which intelligence gives man over the properties of matter and life by which muscular effort can make matter useful. It will be added that this power which the laborer is able to exercise over matter may be either the direct action of the man, or may be indi-

rectly exhibited upon certain inorganic and organic powers: in other words, that the workman may be plying his own muscles, or may be guiding animal power, or be using steam, wind, or any other natural motion which man is able to control and direct for his own ends. In technical language, economists speak of fixed and circulating capital, of muscular and nervous labor. All these definitions and distinctions, however, are not fundamental, but only denote tendencies under which the same facts appear in different forms, or in which one of the circumstances which accompanies the fact is exhibited in different degrees of intensity. Thus the labor of a manager is said to be nervous, that of a workman muscular. But unintelligent effort is of no avail, even for the commonest acts, nor can the sharpest intelli-

gence give effect to its thoughts, except by means of muscular effort. No labor appears to be more characteristic of the brain than the thoughts of a poet or musician are, but both these personages must at least exercise the mechanical function of writing or speaking. Again, it is true that capital is the accumulation of past labor, embodied or condensed in material objects. With one exception, namely, land available for occupation or cultivation in densely peopled countries, there is no object whatever, which possesses value, that has not obtained its value by reason that labor has been expended on it. A sack of wheat, a bale of cotton, a barrel of wine, a wedge of gold, a house, or a spinning machine, possesses whatever value the market assigns to it by reason that labor has been expended on its production. It signifies nothing, from this point of view, whether the article is movable or has been gifted with qualities which cannot be recovered or resumed in their original form. In every case it is labor, and labor only, which confers on these objects those properties which economists recognize and comment on.—*Professor Thorold Rogers.*

The Electric-Harmonic Telegraphic System.

Although there has not been much said of late in regard to the electric-harmonic telegraph invention of Mr. Elisha Gray, constant progress has been made towards developing and perfecting it. Within the past year very important improvements have been made, which materially increase its value and reliability. Mr. Gray has been for several weeks past engaged in demonstrating the system on the wires of the Western Union Telegraph Company, and has certainly shown some remarkable results. On September 21, by invitation of that gentleman, we were present at an exhibition of it in the Western Union building, which was very successful. But one wire was employed, yet it required sixteen operators, eight at each end, to work this single wire. The wire employed was one of the Western Union wires between this city and Philadelphia.

The most important improvement effected by Mr. Gray, since we last noticed his invention, is the successful duplexing of his apparatus, so that messages can be sent simultaneously from each end of the line. With the apparatus manufactured at the present time, four messages can be sent simultaneously from each end of the wire. Upon the occasion mentioned, four operators were engaged in sending and four in receiving, and the same number were similarly employed in the Philadelphia office at the same time on the one wire. Thus eight messages were being simultaneously transmitted and received, at a speed equal to that obtained in ordinary working of a single circuit on one wire, without the slightest interference with each other. The principle upon which this system is based is that of the number of vibrations required to give a musical tone. By very ingenious and simple apparatus, this principle is utilized for the transmission of telegraphic signals simultaneously on a number of circuits over a single wire. The receiving instrument, for instance, which is adjusted to receive the vibrations required to constitute the musical note represented by A, will pick up the signals sent by the corresponding transmitter, but it is not affected by those transmitted at any other pitch.

It is impossible to give a very satisfactory description of the system, apparatus, and connections, without diagrams. We propose, before long, to give a full and accurate description, with the latest improvements, properly illustrated

of this system, which will doubtless be of great interest to all telegraphers. The importance of this invention can scarcely be overestimated. Although eight circuits only have been actually operated by it as yet, there seems to be no reason to doubt but that these may be increased, even to as many as thirty-two: that is, to as many as there are tones and semi-tones in the musical scale. It in fact already duplicates the quadruplex in actual operation, and is more reliable and less difficult to operate than the quadruplex. Mr. Gray has spent several years in developing and perfecting his invention, and there can be no doubt but that it is destined to play an important part in the telegraphy in the future.—*The Telegrapher.*

Our Silk Industry.

The English *Textile Manufacturer*, reviewing the progress of the silk industry in the United States, says that our manufactures of ribbons, etc., for 1875, were double those of 1874; and while other branches of industry were in a crippled state, the silk trade could offer occupation to a greater quantity of able regular workmen than usual, besides being able to afford higher prices. As characteristic of the increased activity of the manufacture in Paterson, N. J., last year, the immigration of English and French workmen is noted. The latter possess their own looms, which they take with them to work on their own account. The import of raw silk, in 1875, was 50 per cent greater than in 1874, and exceeded by 38,807 lbs. the corresponding exports of 1871: the amount in the latter year being the largest yet attained, except that in 1875.

Utilizing Unmarketable Cocoons.

Mrs. Bladen Neill, of London, England, has invented a new utilization of cocoons which are adjudged unfit for use in silk making, and has philanthropically turned her invention to such account as to make it the basis of remunerative labor for women. A certain proportion of every crop of cocoons is rejected, because, the chrysalis having become matured, the moth has made its escape, and thus the filaments at one end of the cocoons are cut through. The continuity of the thread being broken, it loses its value and is useless for reeling. Mrs. Neill sends to various parts of the world and gathers these faulty cocoons, boils them, and reels off the fragmentary filaments. These are sent to the spinners and made into a handsome silk yarn, which is dyed as required, and the material is issued to poor women who convert it into knit goods. The fabric thus produced is of such excellent quality that the demand already has far exceeded the supply.

A NEW FODDER FORK.

Mr. William M. Scotten, of Hall, Ind., is the inventor of an improved fodder fork, patented through the Scientific American Patent Agency, August 8, 1876. The object is to enable the substance to be firmly grasped and securely held while being handled. A and B are the two prongs or tines of the fork, which are pivoted to each other at their bases.

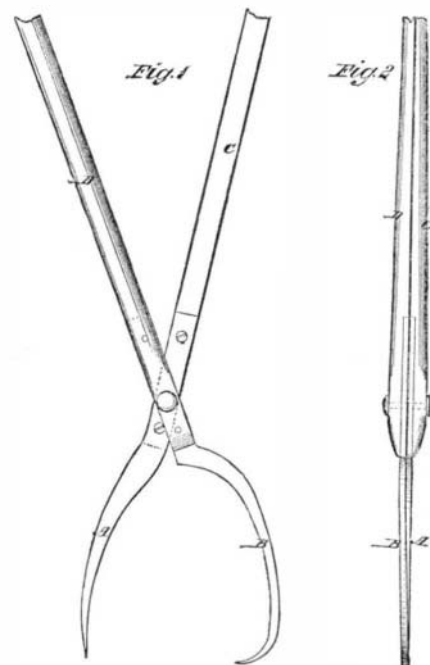

The prong, A, is slightly bent; and the prong, B, is made longer, and its point is bent inward into hook form, so that when brought together the points of the two prongs may meet. To the shanks or bases of the prongs, A B, are attached the handles, C D, which are made half round, so that when brought together they may form a round handle, as shown in Fig. 2, and so that the gripe upon the said handles may hold the prongs together. In using the fork, the prongs are opened, as shown in Fig. 1; the prong, A, is then thrust into the load, the hook prong, B, is closed upon it, and the load is taken to the desired place.

THE American Fish Commission recently held a convention in the Maryland State building in the Centennial grounds, at which Professor Baird stated that 8,000,000 young shad and 8,000,000 young salmon have been distributed in this country in the past year, and 600,000 eggs sent abroad. Mr. Livingstone Slone has just brought 4,000,000 salmon eggs from California.