

IMPROVED CONSTRUCTION OF STABLES.

Mr. Frank M. Dixon, of Jefferson City, Mo., has recently invented a contrivance for hitching a horse and fastening a stable door in such a manner that the horse will be freed and the stable door opened in case of fire in the stable, and a contrivance for sounding an alarm at the same time. The engraving shows a transverse section of a stable having the improved appliances. A cord, of cotton or other combusti-

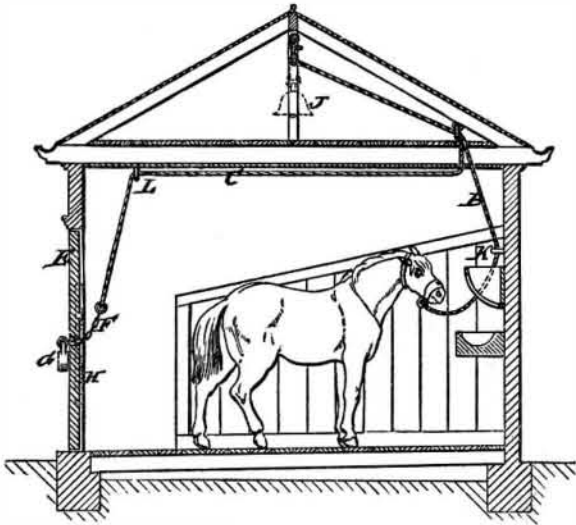

ble material, is stretched along the space above the stable, from side to side, to which the halter of the horse is attached, A cord, C, holds the door, E, shut—say, by a chain, F, and a padlock, G—and the door has a spring, H (dotted line), to throw it open when the cord is released. There is another cord, extending along the space above the stable, from side to side, and connected to an alarm bell, J, and also having the halter and the door cord attached; so that when the cords are burned off by fire, the door will spring open, the horse will be released for escape, and the alarm bell will sound. The halter will pass down from the space above, where it is attached to the cord through guides, K, and the door cord will pass along through suitable guides. The invention was patented on July 18, 1876.

The United States Patent Association.

This society meet on September 7, 1876, at the Franklin Institute, Philadelphia, Pa., for the purpose of suggesting means for the improvement of the patent system and the formation of an international association for promoting uniformity of patent laws in all countries. Among the members present were Hon. J. M. Thacher, ex-United States Patent Commissioner; Professor Hedrick, of the United States Patent Office; W. C. Dodge, of Washington, and John S. Perry, of Albany, N. Y., President of the Association.

President Perry called the meeting to order, and read an address, in which he took as subjects of consideration: First, the importance of the patent system in general; and, second, that of the United States in particular, viewed both in respect to the development of original invention and as inciting inventors to persevere in the perfecting of their plans. He showed the benefits which have arisen from the patent system by a review of the condition of Europe before the patent law was recognized. So long as the laws of property were neither recognized nor properly defined, there could be little incentive to invention or the pushing forward of appliances for the better comfort of mankind. Often an individual, like Roger Bacon, would be on the eve of an invention, and often for that matter did invent; but, well knowing that his rights would be unrecognized, he failed to make it public. Indeed it is well known that several inventions and discoveries of great value, which have since been re-invented, were really made, but suffered to die with the inventor or discoverer from this cause. The first trace of patent law is, he thought, to be found in the reigns of Henry III. and Edward IV., of England, in the thirteenth and fifteenth centuries, about which periods the services of the villains or serfs gradually became less onerous and uncertain.

He furthermore said: "Patents are sometimes characterized as monopolies and even as vicious monopolies. With equal reason might the possession of wealth honestly acquired be denounced as a trespass upon the rights of others. To take money unlawfully is called stealing; to appropriate an invention is not by some considered very dishonorable. The public seem to have lost sight of the fact that the inventor has taken nothing which it had before; that he has from his own brain brought into existence and perfected, at his own cost of labor and money, a production as new to the world, and perhaps as useful, as the gold which the miner brings forth from the hidden recesses of the mountains. The most bitter opposition the patent system meets is from the agriculturists, and they of all men are the most benefited by its provisions. With the high cost for labor that has existed during the past twelve years, the business of farming could not have been carried on without the improved machinery that inventors and progressive manufacturers have provided.

"The importance of the patent system in general is shown in that a vast number of articles have been through its instrumentality added to the means of human happiness, of which the latter must otherwise from necessity have been deprived. In reference to the importance of the patent system in the United States, the speaker argued that the history of patent protection is almost coincident with our existence as an independent nation. The law of patents, as it now stands in the United States, rests on the statutes of

February 21, 1783, and April 7, 1800. These statutes have been modified several times, yet our patent law as it now stands is far from being perfect, and it is in the hope of aiding in correcting its errors, and in giving it a wider scope, that the United States Association has been formed."

REMARKS: These views are in the main sound, although tinged with a few misconceptions. Patents, the chairman assumes, are not monopolies, but inherent rights. The poor miner, who controls the gold that his industry brings from the rocks, is just as much of a monopolist, he tells us, as the wealthy patentee, who compels every poor woman to pay him forty dollars royalty, for the privilege of earning her living by means of his patent sewing machine. Such reasoning, Mr. Chairman, will not do. The people know better. They know by actual daily experience that patents are monopolies, some of them of the most oppressive kind; and no sugar-coating by any Patent Association will alter the fact. It is because patents are monopolies of the vicious kind, that they are valuable, and in such great demand. Of what account would a patent be, if the patentee were not clothed with authority over his fellow creatures to enforce his private demands, in respect to his patent? Of none whatever.

According to President Perry, the miner who first discovered gold in the Rocky Mountains was the natural patentee of the entire range, as respects the precious metal. He takes nothing that the public had before; on the other hand, by his discovery, he contributes to the general supply of gold. Therefore, no one but the discoverer, or the favored few whom he permits, ought to be allowed to work at gold mining on the premises. This is poor logic for the United States Patent Association to promulgate.

Patents, as we have stated, are pure monopolies. They are only tolerated and granted for reasons of public policy. They are issued solely as rewards: for the mere purpose of stimulating people to discover, invent, and study out new forms of industry. The general weal is promoted by increasing the number and variety of industrial arts, which all the people may freely and equally enjoy. Instead of rewarding the inventor by paying him a sum in cash from the collected taxes in the treasury, the government gives him a patent, or, in other words, makes him his own tax gatherer; and authorizes him to compel the people, by force if necessary, to satisfy his demands.

The redeeming feature of our patent monopoly system is that it effects its object, it brings out new improvements, and is limited to a brief period. Our patents run for seventeen years—a short time in the life of a nation; the inventions then become public property, and everybody may enjoy them, free from the annoying whip and spur of any wealthy private corporation or patent holder. Great as are the inconveniences of our patent system, the benefits are amazing, and greatly exceed the drawbacks. So long as this continues to be the case, the patent laws will stand.

A PAPER EGG CUP.

Here is a new APPLIANCE of that all-useful commodity, paper, to the purposes of table furniture. Mr. R. M. Washburn, of Burlington, Iowa, has patented a paper egg cup, which, besides being a really ingenious idea, is based on sound theory, inasmuch as paper is a non-conductor of heat; it is elastic, so that one cup will hold securely an egg of any size; and it is molded in corrugated form, so that there is always a

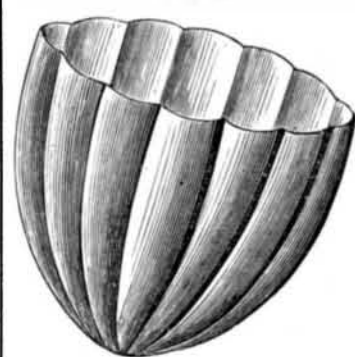

circulation of air between the egg and its vessel, which is represented in our engravings as empty in Fig. 1, and holding an egg in Fig. 2. The same cups may be used over and over again, or may be thrown away after each meal, their cheapness allowing of this latter disposition. They are handy for picnic parties or for persons traveling, and as novelties for hotels, restaurants, and even private houses. The material may be paper, muslin, or almost any fabric. Tinted of different colors, the cups would be quite ornamental; or they might serve as a medium for advertising, so that the person using them may have food for digestion mentally as well as physically. The invention is one likely to be remunerative. It is just such cheap and simple devices which, now-a-days, are most in demand, and produce the largest profit. Those desiring to negotiate for the right to manufacture can obtain further particulars by addressing the inventor as above.

Fig. 2.

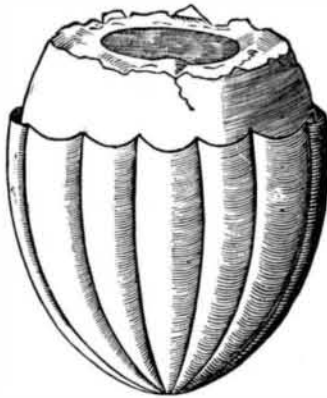

A SIMPLE DIVIDING MACHINE.

Among the exhibits of the Massachusetts Institute of Technology, at the Exposition, is a novel instrument devised by the professor of physics, to be used as a dividing machine for graduating scales of equal parts. It can be

constructed for a trifling outlay by any one who understands the use of tools, and by its aid scales can be laid down with considerable accuracy. It consists of two strips of wood, A, B, which slide in a wooden frame, E. The ends of a cord are fastened to these strips, the cord being fastened, as shown in the engraving, to the weight, C, which is heavy enough to slide the strips along the frame. The slips can, however, be kept in any desired position, by placing weights upon them.

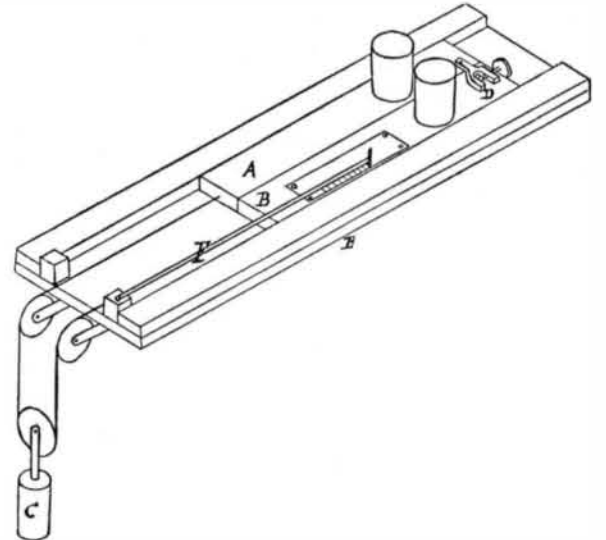

At the upper extremities of the slips is a fork-shaped piece of metal which is secured to the strip, A, by a pin, on which it can turn; and a pin on the strip, B, engages the fork, allowing a certain amount of play, which can be varied at pleasure by the adjusting screw, as shown in the engraving. An arm, F, is attached to the frame by a pin, and has a pencil at the end, this being the marker for constructing the scale on a piece of paper which is fastened to the strip, B. To show the action of the instrument, suppose the adjusting screw is turned so that the play of the fork is $\frac{1}{100}$ of an inch. A piece of paper is secured to the strip, B, and a mark made upon it with the pencil. The weight is then lifted from the strip, B, when it will be slipped along a distance equal to the play of the fork, or $\frac{1}{100}$ of an inch, and a second mark is made with the pencil. Then the weight is replaced on the strip, B, and that on the strip, A, is removed, when B will be slipped along until it is square with B, a stop preventing the fork from turning back any further. The weight is replaced on A, the other removed from B, a third mark made, and so on, alternately moving each strip through the required distance, until a sufficient number of divisions is obtained. R. H. B.

NEW COMBINATION TOOL.

Mr. Lester Beach, of Derby, Conn., is the inventor of a novel and ingenious combination tool, an engraving of which is presented herewith. The body of the tool consists of two parallel bars, connected at their ends, and at suitable distances apart between said ends by crossbars, so as to

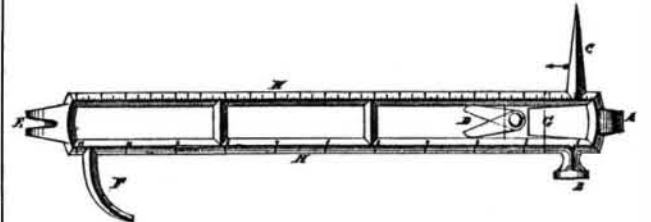

make the tool light and at the same time strong. Upon one end of the tool is formed a screwdriver, A, near which is a hammer head, B; and upon the other edge is an ice pick, C. To one of the crossbars are attached two small steel plates, D, arranged at an angle, so that they may be used as a knife sharpener. Upon the other end of the tool is formed a notched claw, E, for pulling tacks and for lifting stove covers. Upon the edge, diagonally opposite the ice pick, C, is formed a curved finger, F, which may be used as a poker and as a pot lifter. At one end the space, G, is made slightly tapering, and the inner edges of the side bars are flattened, to adapt said space to be used as a wrench for turning various sized nuts. Upon the side bars of the tool are formed division marks of inches and parts of an inch, to adapt the tool to be used as a rule, H. Patented through the Scientific American Patent Agency, August 1, 1876.

The East River Bridge.

Chief Engineer Roebling now intends to hoist a carrier rope of $1\frac{1}{2}$ inches diameter, instead of $1\frac{1}{4}$ inches, as originally intended, between the towers of the East river bridge. The increased weight will prevent the carrier rope from being hauled across by the traveler ropes now in place; and it will have to be carried across the river in a scow and hauled taut between the towers, as was done in the case of the first traveler rope. Two $1\frac{1}{2}$ inches carrier ropes will be placed in position; and then the cradle and foot bridge ropes will be hung on them by pulleys. The carrier ropes are of chrome steel wire, and will weigh about 22,000 lbs.

A Statue of Lafayette.

The French republic has recently sent, as a gift to the citizens of New York, a bronze statue of Lafayette, the renowned soldier whose zeal in the cause of republicanism brought him to this country 99 years ago, and enlisted him in the army which achieved our independence. The statue has been erected in Union Square, looking down Broadway; and it was unveiled on September 6, with appropriate ceremonies.