

**THE LIDGERWOOD ROTARY ENGINE AT THE EXHIBITION.**

We have already explained the construction of this machine and some of its other forms, in previous issues. It is sufficient here to point out some of the advantages of the type illustrated, which is designed for hoisting in mines and quarries, and represents one of eight similar engines lately completed by the manufacturers for Messrs. L. B. McCable & Bro., of Baltimore, Md., for use in the permanent water supply tunnel of that city. The machines, being reversible, are each connected with two elevator platforms, one of which ascends while the other descends. They lift 6,000 lbs. with a single rope at a speed of 200 feet per minute, and at about 60 lbs. steam pressure. Larger sizes of the engine are capable of hoisting up to 7 tons, at 250 feet per minute. There are no centers, and by manipulating the single lever the steam is made to hoist, lower, or hold the load.

Small hoisting engines of the Lidgerwood type are now in use on board steamers for raising coal, ashes, etc., and have found a wide utilization in quarries and along docks where cargoes are constantly handled. The portable engine and boiler, which is the third form in which the machine is constructed, is a very completely arranged apparatus, containing everything in the shape of necessary fittings, including a compact heater for the feed water. It is made self-propelling if desired. Still another form is the adaptation of the rotary engine to platform elevators, such as are used in hotels, warehouses, stores, etc. This has compound gearing, which runs noiselessly, and a brake on the flywheel for controlling the load, manipulated by the same lever that governs the engine. There is also a governor for regulating the rate of speed in hoisting or lowering, and the construction throughout renders the machine well adapted for the especial purpose for which it is built.

All of the above forms may be seen at the Centennial Exposition. The small hoisting engines will be found at work raising ashes in each of the three boiler houses. Several other Lidgerwood engines are at work at the Centennial.

Another adaptation of the rotary engine, and one which has deservedly attracted considerable attention of late, is to the propulsion of small steam yachts or launches. We are informed that in this particular the Lidgerwood machine has attained considerable success. Nine boats, varying in length from 28 to 50 feet, have been fitted with the engine; and one, now in process of building, which is to be 42 feet long, with 6 feet beam, and 3 feet 6 inches depth of hold, is to be propelled at the speed of 12 miles per hour by a Lidgerwood engine equal to a 5x6 inch reciprocating machine.

Among the other advantages of the device, not yet noted, are its simplicity, it having but eight pieces exclusive of bolts, its smoothness and rapidity of action, the fact that its working parts are covered, the absence of brakes, except of course in the elevator engine, and its general utility for all purposes of hoisting or elevating.

Further particulars may be obtained by addressing the Lidgerwood Manufacturing Company (P. O. box 2,132), 165 Pearl street, New York city.

**WOOD'S IMPROVED PISTON.**

We illustrate herewith a universal expanding device for

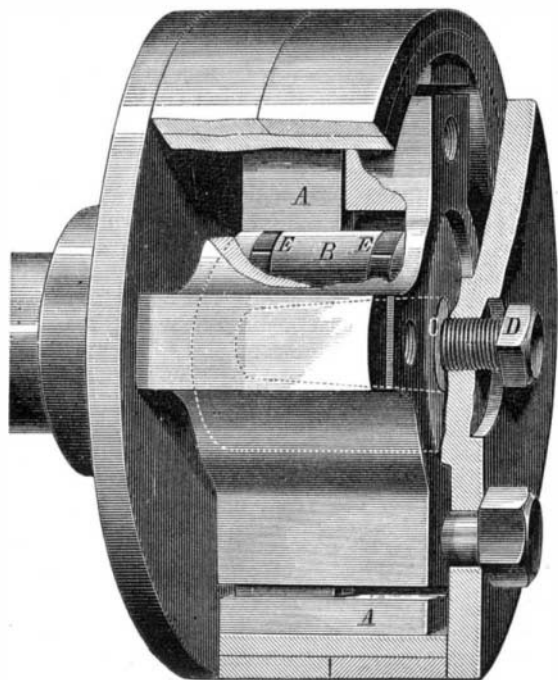

the pistons of steam engines, which is capable of expanding the packing rings equally with a positive motion; so that, while the piston can be adjusted as desired, it acts, while working, like a solid piston. While, therefore, it can be regulated so as to take up the usual wear, it will not ac-

commodate itself to the inequalities of the cylinder, nor wear more in one place than in another. A further advantage offered, as will be seen from the following description, is that the necessity of removing the follower in order to adjust the packing, is obviated.

At A are the followers, which slide in suitable ways in the piston head. B is a central core or cylinder, which is bored out conically, as indicated by the dotted lines, and which is provided with a conical plug, C, which is forced in by the screw, D. The core is made in segments held together by circular springs, E, placed in grooves on its exterior. The followers abut upon this core, and also have feet which press against the packing rings, so that, when the plug, C, is forced in by the screwdriver, the core is expanded, and the followers, driven outward, produce a uniform ex-

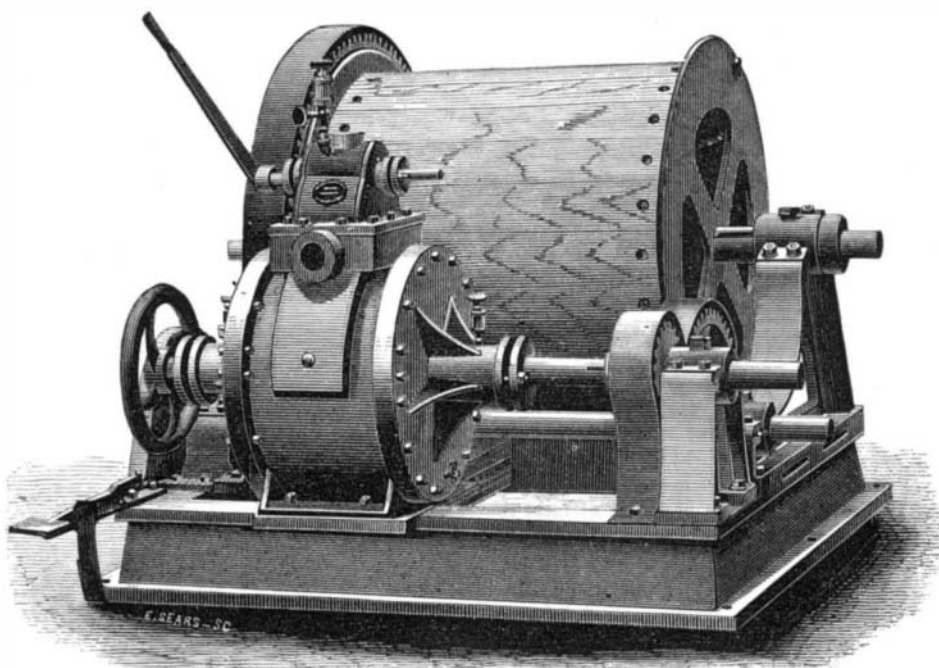

**THE LIDGERWOOD ROTARY ENGINE.**

pansion of the rings. The piston rod, instead of passing through the head, is screwed into a boss cast on one side of the head, and the plug, C, may be easily removed when desired.

Patent pending through the Scientific American Patent Agency. For further particulars address John Wood, Jr., Conshohocken, Pa.

**BEDELL'S SEWER GAS TRAP.**

We illustrate herewith a recent invention in a very important department of sanitary engineering, that which re-

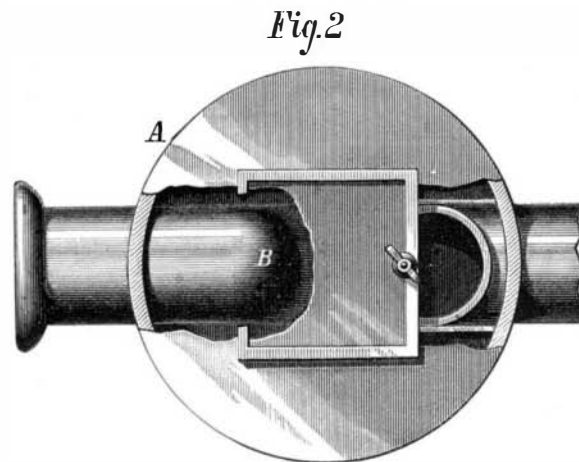
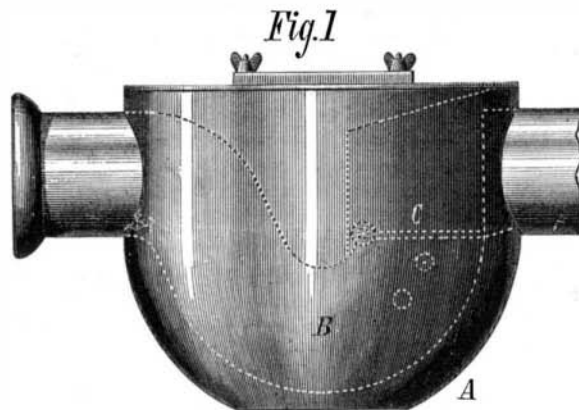

lates to house drainage. It consists of a terra cotta tank, A, 18 inches deep by some 16 inches in diameter by 1/4 inch thick, inside of which is a U-shaped pipe, B, 6 inches in diameter, also made of terra cotta, the pipe and the tank being cast or molded in one piece. A little below the bottom of the outlet or discharge pipe, this siphon is closed by a copper valve, C, which, when down, is entirely under the water which fills the whole interior of the tank to a height of some two inches above the valve. The tank again is sealed perfectly watertight, the cover being molded on the tank before it is baked, and the opening (shown in Fig. 2) closed by a thick plate of glass imbedded in putty and held down by thumbscrews. Around two sides of the valve, as shown in Fig. 1, are sheets of copper or tin, so that, when

the valve is up, all connection with the tank is cut off, and the sewage thus prevented from entering the tank and forced to go out by the discharge pipe.

The action of the trap, then, is this: The matter to be discharged enters through the pipe, which is provided with a flange or lip, flows down the siphon, and lifts the copper valve, which, as it rises, cuts off, with the two copper sides placed at right angles to it, all connection with the tank, and forces the sewage to pass out through the discharge pipe. When the matter has passed out, the valve falls, closes the opening in the pipe, and thus the process known as siphoning, by which the water is so often drawn off from similar traps, and the gas from the sewer thus allowed to pass up through the house, is prevented. The gas which comes up the discharge pipe from the sewers can, by this arrangement, get no further than the tank, for the siphon is closed by the metallic valve lying two inches under water, and the tank is filled with water to a few inches of the cover, and hermetically sealed, and the small amount of gas that does find access to the tank cannot escape either by the pipe or the tank cover.

It is well known that a sewer gas trap, to be of any service whatsoever, must accomplish two things: it must render impossible the process known as siphoning, and must offer a mechanical resistance to the pressure of sewer gas, to prevent the gas being forced through the water. These two important features are claimed to be accomplished by the invention described. We are informed that the time required to set one in perfect working order is ten minutes.

For further particulars address the patentee, Mr. William Bedell, 985 Eighth avenue, New York city.

**Sensible Assertion.**

The Colorado Farmer, published at Denver, utters the following truthful sentiment: Now is the time when the intelligent and educated farmer is going

to have the advantage over the one who does not keep himself posted. When times are good, any one who knows how to raise good crops makes money. But when the country seems to have too much of everything in it, the man who picks up the improvements first, and who has raised good big crops cheap, is the man for the times; and we have to say that no man of brains, who has taken up farming for a business, should quit it now; for he cannot sell out without loss, and the time is sure to come when he will do well.

**HOSE ATTACHMENT FOR FAUCETS.**

It has been well said that few great conflagrations have ever occurred which a pail of water would not have extinguished, had it been on hand at the proper time. There are so many causes of little fires which may easily grow into great ones, in every dwelling, that it is a good plan to have the needful pail of water, or its equivalent, always ready; but as filled pails are not handy articles to leave promiscuously about a house, especially where there are children, the ingenuity of inventors has been taxed to supply some other means for a prompt water supply. Such a device is that herewith illustrated, it being nothing more than a length of hose provided with a nozzle, as shown, and coupled to an enlarged portion of the ordinary basin faucet. The hose is long enough to lead to any part of the adjacent room or rooms; so that in case a coal falls out of the grate and sets the floor on fire, or a curtain blows out the gas flame, or a lamp upsets, or any similar accident occurs, it is not the work of a minute to lead out the hose, turn on the water, and at once play on the incipient blaze.

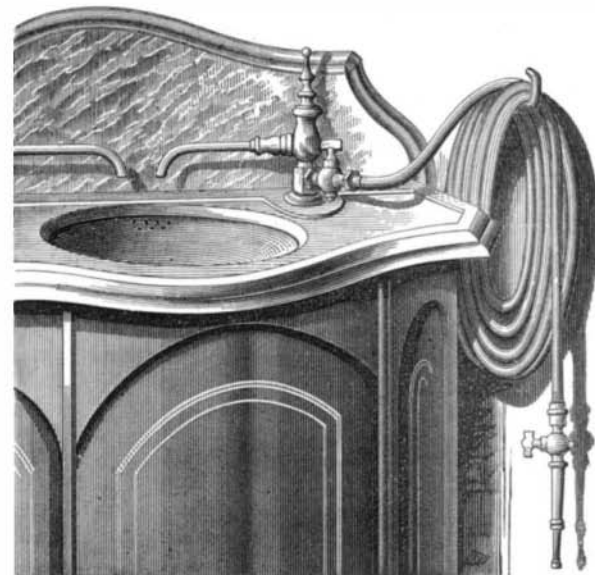

The device can be used wherever there is a water pressure whether derived from a tank on the roof or from the town mains. It will also be found useful for shampooing purposes. It is one of those simple yet handy little inventions which may often be the means of saving valuable property. Patented July 18, 1876. For further particulars relative to sale of rights, etc., address the inventor, Mr. D. G. Tremole, 103 South Fourth street, Brooklyn, E. D., N. Y.