

**HANGINGS FOR SLIDING AND SWINGING GATES.**

The invention herewith illustrated is an improved attachment, or iron, for that class of gates which are opened by sliding them back upon a proper bearing surface in the gate post until a balanced position is reached, and then swinging them round upon the bearing as a center. The device is composed of two cast iron brackets, a transverse slotted swivel, and a bearing wheel, all as shown more clearly in Fig. 2. The brackets, A, are provided with projections having suitable bearing openings for the iron which revolves therein. The projecting portion of the brackets, it will be observed, extends in a diagonal direction from the face of the post. The bearings are thus adapted to permit the iron held thereby to lie parallel to the side or face of the post, as may be desired. The swivel iron, B, consisting of a casting provided at each end with bearing studs, rests in the bearing openings of the brackets and turns therein. The bearing wheel, C, the circumference of which is less than the inner circumference of the circular opening in the swivel, is provided with journals which rest upon bearings at the bottom of the vertical slots.

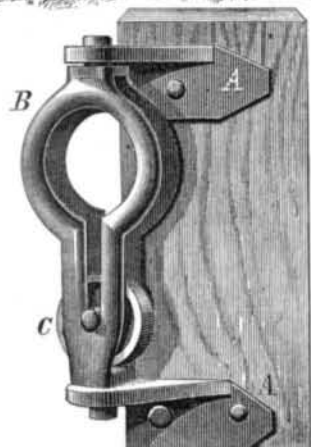
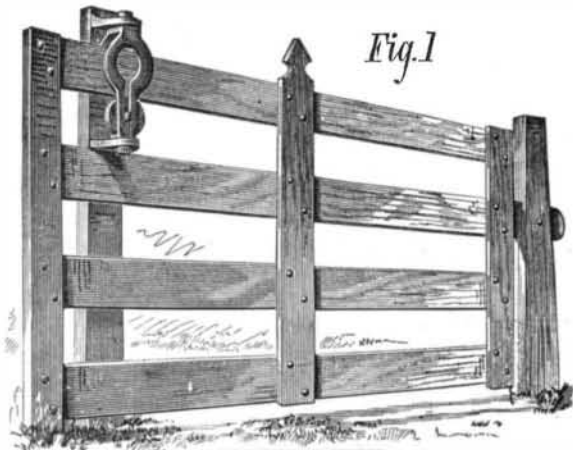

The gate, Fig. 1, is constructed as desired, and one of its bars is held in the slot, passing through the swivel iron and resting upon the bearing wheel. The operation of the gate is similar to others of its class already noted. It is closed, of course, by the opposite movement. Some of the advantages claimed for the described construction are as follows: By constructing the iron with the large circular opening and vertical slots, the bearing wheel may be readily inserted in its place and be securely held there without the necessity of drilling journal holes or inserting pins. The extended bearing surface, also furnished by this form of casting, serves to hold the gate bar always in line with the bearing wheel, so that the tendency to cramp or pinch when the gate is longitudinally moved is avoided. The attachment as a whole is strong, durable, and simple in its construction, it being complete and ready for use when cast, without drilling or finishing of any kind, so that it can be made at a small cost.

We are informed that farm gates put up with this device need no bolting nor bracing; and as they rest with each end squarely on the gate posts, they will neither warp nor sag. They can be raised up so that sheep or hogs can pass under them. The gate may also be placed on the side of a steep bank or over snow drifts.

This invention was patented July 25, 1876, by Elias Shopbell, of Floris, Iowa, by addressing whom further particulars may be obtained.

**Coal Dust as Fuel.**

The use of dust and pea coal has been thoroughly tried at the Ocean Mills, Newburyport, Mass., for the past year and a half, with the following result: For years they have kept an actual account with scales of every barrow of coal wheeled into the fireroom, and the average weekly consumption shows forty tons of broken coal on 18,000 lbs. of cloth, average costing \$7 per ton, or \$280 per week, which makes the cost of fuel per pound of cloth over 1 1/2 cents; under the present arrangement, the weekly consumption is only thirty-six tons of pea and dust on 20,000 lbs. of cloth, costing \$3 50 per ton, or \$126 per week, which makes the cost of fuel per pound of cloth less than six mills, showing a saving of nearly one cent per pound. This mill is run entirely by steam, and the cost of one and a half cents per pound in burning large coal does not vary from the cost of other mills in the same vicinity. Beyond the saving of fuel, the fire is much easier on the boilers, brickwork, and fronts of furnaces, no repairs having been made on any of the above since the arrangement was put in; and the grates are as perfect as new. This one item almost pays the expenses of the arrangement. The labor is not near as hard on the

firemen, and the engineer has the steam under entire control. Again, if steam is drawn down rapidly, as in dye works, it can be brought up again in a quarter of the time.

The want of market for dust, heretofore, has caused its being dumped off on to the dirt piles at the mines at a much greater cost than if loaded into cars; and the accumulation at the shipping ports has been of such inconvenience that thousands upon thousands of tons have been dumped under the docks to get rid of it. Much of the pea coal has been thrown, also, upon the dirt piles, all of which will now be carefully saved, and shipped to market, the present arrangement developing more steam from one ton than we got from the same quantity of any larger sized coal.—*Boston Transcript.*

**Action of Impure Rain Water on Lead Pipes.**

In a paper lately read before the American Chemical Society, Professor Paul Schweitzer says: The laboratory of the University of Missouri is supplied with rain water, which collects in a tank in the upper part of the Scientific Building, and is carried to the working tables of the students by lead pipes, which are furnished by brass stopcocks. In using this water for ordinary analytical work, as, for instance, saturating it with sulph-hydric acid, it was soon found to be unfit for such purposes, on account of the quantity of metals it had dissolved, after standing in the pipes only a short time. It is a well known fact that pure water attacks lead much faster than water containing a certain quantity of mineral salts, and this seems to be also the case with rain water, which contains invariably ammonia, nitrous and nitric acid: some sulphuric acid was also found in this water, derived from the smoke and cinders which fall on the roof of the building from the coal fires that heat the rooms. The following quantities of metals were found in one United States gallon, 231 cubic inches, of the filtered water, that had stood in the pipes for one month: 1.079 grains metallic zinc, 0.537 grains metallic iron, 2.503 grains metallic lead, 0.082 grains metallic copper, 0.049 grains metallic arsenic. Total, 4.250 grains.

Arsenic, copper, and probably iron, are derived from the lead pipe, manufactured from an inferior quality of lead, and zinc from the lining of the tank. In supplying private houses or institutions with water through a system of pipes, care should be taken to find out whether the water to be supplied be pure or not: in the former case, and when rain water is the source of supply, as it is in many sections of our State, lead pipes should be discarded, and tin-lined lead pipes substituted for them.

**A MARINE SAFE.**

Few of the great ocean steamers now leave our ports without carrying large amounts of bullion and specie. In case of the wreck of the vessel, this precious freight is likewise lost, since its weight and that of the heavy safes in which it is inclosed necessarily carry it to the bottom when the ship breaks up. Sometimes, and of course only when the disaster occurs in comparatively shoal water, a buoy is attached to the safe, and the latter, if time permits, is thrown overboard. The location of the buoy then marks that of the sunken safe, and it is not difficult to regain the latter.

A much better plan than this, and one that is well worth the attention of ship owners, insurance companies, and others, has lately been patented through the Scientific Ameri-

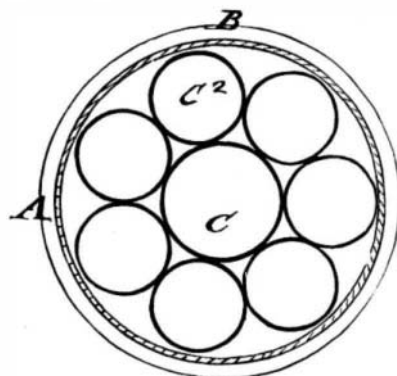

can Patent Agency (August 1, 1876) by Mr. J. L. Gouley, of New Orleans, La. This inventor proposes to make the safe itself a buoy, in the manner exhibited in the annexed engraving.

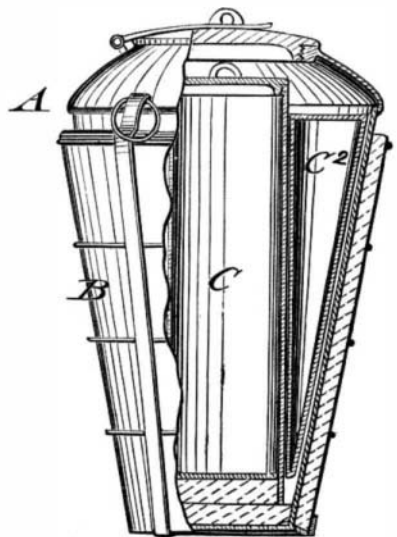

ings. A is a sheet copper vessel, the lower part of which, B, is covered with rubber so as to resist the shock of being tossed on breakers. Inside the vessel, A, are a number of

compartments, those marked C<sup>2</sup> being hermetically sealed and containing only air, while the center one, C, is designed for the reception of treasure. There are two covers: one for the center compartment, the other for the main vessel, as shown, the latter being provided with suitable locks. It is intended to mark the safe conspicuously with the name of the owners, and then, in case of wreck, throw it overboard, so that, if not washed ashore, it is certain to be picked up at some time.

**THE ACME AUTOMATIC DRAFT REGULATOR.**

We illustrate herewith a novel and ingenious device for regulating the draft of a fire, and which also is claimed to obviate the danger arising from overheated flues. Generally, all smoke pipes are provided with a common close damper for regulating the draft. When this damper is closed, or partially so, the combustion is slow and imperfect, the gases accumulate, and when there is not a free exit they become forced into the rooms. The common damper likewise requires frequent manipulation by hand, to suit circumstances, while the present device does not at any time retard the free exit of smoke and gases, but allows them to pass into the flue as they are generated; it likewise is self-acting in its operation so far as not to require frequent adjusting and so as always to permit the necessary amount of draft for the proper combustion of the fuel.

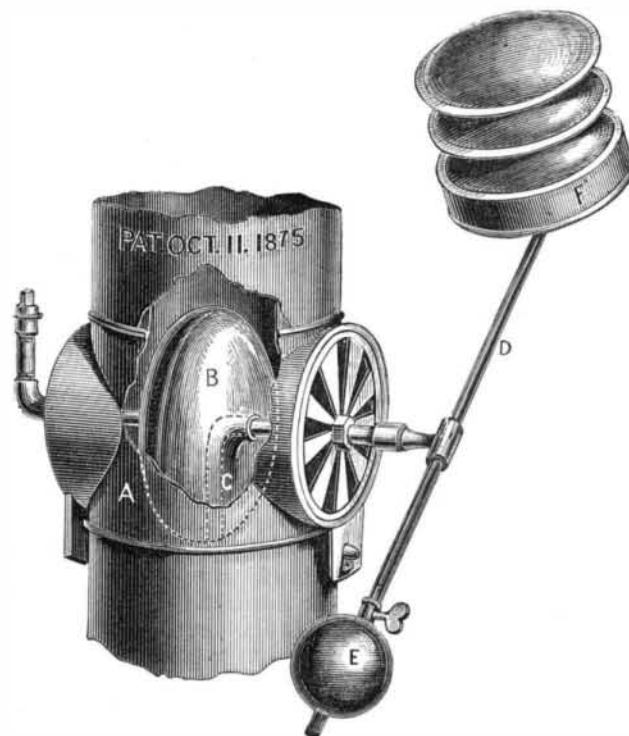

A is a cast iron collar that fits on the smoke pipe, with double open and shut valves. B is a small cast iron boiler without joints, suspended within the pipe in such a manner and of such shape as not to impede the passage of smoke or gases. C is a siphon pipe, leading from the bottom of the boiler to the exterior lever arm, D. This lever, D, is a continuation of the siphon pipe, weighted at one end with the weight, E; at the other end it carries the metal receivers, F. It is connected as shown with the valves in the collar, A.

The action is as follows: With a moderate amount of heat passing up the chimney, the water in the boiler remains at or near the boiling point, and the valves remain closed; but as soon as the volume of heat is materially increased, steam is generated, which forces a portion of the water through the siphon pipe into the lower metal receiver. The latter then partially overcomes the weighted end and the disk descends, partly opening the air valves in the smoke pipe, admitting a current of cold air which serves to reduce the force of the draft in like proportion. Any further increase in the volume of heat passing into the smoke pipe will likewise increase the steam pressure, forcing a greater weight of water into the receivers and opening the air valves wider and reducing the force of the draft to its lowest point necessary for combustion. As soon as the fire is checked and the smoke pipe cools, the water gradually returns to the boiler, reversing the action; and the draft is gradually increased until the process is again repeated. Thus the fire itself is the agent for regulating its own draft.

There is claimed to be no danger of explosion, for, as state the manufacturers, were the boiler to become red hot, the water would be forced out of it into the receivers, and cannot return again until it has cooled. Though the air valves are self-regulating, and are acted upon by the force of combustion, they can be manipulated by hand if desired, by simply sliding the weight on the arm of the lever, which will open or close the valves, as may be desired.

The device can be readily applied to any stove or furnace, where the smoke pipe is over five inches diameter, either on a vertical or horizontal pipe. Patented October 11, 1875. For further particulars address the S. J. Gold Heater Company, 93 Liberty street, New York city.

**Joint Stock Maternity.**

A Welsh correspondent sends to *Nature* an interesting instance of a joint stock concern in the poultry yard: "Two hens sat on, or by, one nest, and thus between them hatched one chick. They have since, for some weeks, been parading the yard, each clucking and manifesting all the anxiety and care of a true mother over this one. The hens never quarrel, or show the least appearance of jealousy or rivalry."