

**IMPROVED PIPE CUTTING AND THREADING MACHINE.**

Messrs. Joseph B. Eaton and Charles Latham, of Shamokin, Pa., have patented (July 4, 1876), through the Scientific American Patent Agency, an improved pipe cutting and threading machine, that may be worked effectively in a very narrow space, so as to produce a saving in time and labor in the digging and the working of the machine. Fig. 1 is a top view of the cutter and threader, and Fig. 2 a sectional end view of the same.

The shell or casing, A, is made of two hinged sections, which are applied around the pipe to be worked upon, and locked firmly together by a suitable device. The threading dies, B, and the cutters, C, are guided in interior recesses of the shell, and adjusted or fed forward to the required depth of cutting by means of set screws worked from the outside of the shell. The shell is cast at the ends with raised ratchet teeth, D<sup>1</sup>, along which an operating handle, D, is guided at both ends by an outer arc-shaped part, b, and an inner concentric piece, d, that slides in a recess of the shell below the ratchet. The outer guide pieces of the handle, D, lock, by spring pawls, D<sup>2</sup>, into the ratchets, to take hold of the shell, and turn it in one direction, while releasing it when turned back in opposite direction. A drawing pipe, with threaded end, fits into the threaded end of the shell, and is attached by clamp screws tightly to the pipe to be threaded, drawing by the screw the threading machine forward for cutting the thread on the pipe.

When the pipe is threaded, the machine is returned for clearing the thread by a semicircular handle with hook end, that is inserted into the small socket holes, e, of the shell.

It is claimed that thus a deep or shallow thread may be cut on water and gas pipes of different sizes with ease and rapidity while the cutting is done in perfect manner without leaving a shoulder at the end of the pipe.

**South African Railways.**

A line of railway 120 miles in length was recently opened between Cape Town and Worcester, South Africa. The road is an extension of the Cape Town and Wellington Railway, purchased by the government some years ago, and is part broad and part narrow gage. It is intended eventually to make the whole line of the latter description. Railway work in other parts of the colony is being vigorously prosecuted; 65 miles of road are nearly complete on the eastern line from Port Elizabeth, 60 miles on the border line, from East London, will be ready by the end of the year, and a similar distance on the Midland line will shortly be finished. The estimated cost of the new works was about \$30,000 per mile, but this has been exceeded by as much as \$3,500 per mile in some cases, the increase being accounted for chiefly by the deficient supply of labor, enhanced rate of wages, and high cost of provisions.

**Meteoritic Iron in our Church Steeples.**

On August 10, the earth passed through the great belt of meteors; and on about November 13, it will again plunge into the midst of these vagrant bodies. People who are curious about meteoritic iron, or who desire to investigate that substance, will probably therefore find the present a good time to look for it. M. Tissandier has lately shown that the metal is constantly found in the cosmical dust, which often may be collected from rain, and which exists in the atmosphere of elevated regions. Most of the meteors which strike our atmosphere are at once dissipated by the heat of intense friction, and the iron, melting, falls like shot, in the globular or nearly globular form in which M. Tissandier has found it, and which, he thinks, is one convincing proof of its celestial origin. M. Yung recently told the French Academy of Sciences that the best places in which to look for meteoritic dust is an old church steeple. Collect all the dust which has become deposited in out-of-the-way corners, where the wind has not been able to reach it, and examine it under the microscope. Apart from learning how many curious things are floating about invisible in our atmosphere, the student may be able to get together sufficient of the iron to examine it by chemical means.

**IMPROVED SAND AND GRAVEL SEPARATOR.**

Builders, masons, roadmakers, contractors, and others will doubtless be interested in the invention herewith illustrated, which is adapted for screening sand and separating gravel, overcoming the slow and tedious process now in use. It is claimed to screen sand, no matter how wet, when it cannot be screened by any other process. It separates the gravel entirely from the sand, and deposits the roofing gravel and

coarse gravel for walks, etc., in separate places from the sand, thus saving the necessity of a second screening when roofing gravel is in demand. It can be worked to screen thirty yards a day, by one man throwing the sand and a boy to turn the crank. It works rapidly, and will supply any grade of sand.

A is a coarse screen on which the sand is thrown and which keeps large pieces from passing into the machine. The sand passes down to the feeder, B, which carries it

The manufacturers also make a large-sized machine to be run by horse or steam power, having one elevator to raise sand and another to carry the sand into bins, cars, or other places of deposit.

For further information address the manufacturers, Messrs. Chambers & Quinlan, Decatur, Ill.

**The Human Voice Transmitted by Telegraph.**

Several weeks ago we gave a sketch and description of the thread telegraph, consisting of two small tin or wooden cylinders, each having a membrane stretched over one end, the two membranes connected by a stout thread. Two persons may readily communicate the sounds of the voice by means of these instruments over a thread fifty or a hundred feet in length. The person sending speaks within one of the cylinders, which causes the membrane to vibrate; the vibration passes along the stretched thread to the membrane of the other cylinder; which being held to the ear of the person receiving the message, the vibration is duly heard, or, in other words, the voice of the sender is made audible.

Professor Graham Bell, by a device somewhat analogous, has succeeded in transmitting the tones of the human voice by telegraph. Instead of the thread he connects the membranes of the two cylinders or drums with the armatures of the electro-magnets, one drum being placed at each end of the telegraph wire. In fact, he not long ago demonstrated the possibility of conveying vocal sounds by means of the ordinary telegraph wires and special appliances for transmitting and receiving the sounds. The apparatus used by Professor Bell is thus described: Two single-pole electro-magnets, each having a resistance 10 ohms, were arranged in circuit with a battery of five carbon elements—the total resistance being about 25 ohms. A drumhead of goldbeater's skin, about 2½ inches in diameter, was placed in front of each electro-magnet, and a circular piece of clock spring was glued to the middle of the membrane of each drumhead. One of these telephones was placed in the experimental room, and the other in the basement of an adjoining house. Upon singing into the telephone the sounds of the voice were reproduced by the instrument in the distant room; and if two persons sang simultaneously, the two notes were audible at the other telephone.

At the time of the lecture, an experiment was made to show the transmission of articulate speech, an assistant going into the adjoining building where one of the telephones was placed. Several familiar questions were, it is said, understood after a few repetitions. The vowel sounds alone are those faithfully reproduced; diphthongal sounds and round vowels are readily distinguished, but consonants are generally unrecognizable. Now and then, however, a sentence comes out with almost startling distinctness, the consonants as well as the vowels being clearly audible. Professor Bell stated that telephonic effects can be produced with three varieties of currents—the intermittent, the pulsatory, and the undulatory. The first are characterized by the alternate presence and absence of electricity in the circuit; the pulsatory current by sudden changes in intensity, while undulatory currents are obtained by gradual changes analogous to the changes of density of air produced by vibrations of a pendulum.

The most recent trial of Professor Bell's instrument was at his residence, Brantford, Canada, August 11. The Toronto Globe states that instruments were placed, one in the porch of the residence and the other in an outhouse on the grounds, and communication between these made by ten miles of wire. Musical notes, the human voice, and songs spoken and sung before one instrument were plainly audible by placing the instrument to the ear at the other. By this invention, too, any number of messages can be conveyed over one wire in either direction, provided they have a different pitch; the tones of the voice can pass over the electric wire, enabling the hearer at any distance to hear distinctly what is said, and to distinguish the voice of the speaker. On August 10 the professor had communication made with his instrument on the common telegraph wire between Brantford and Mount Pleasant (five miles), and was spoken with, while in Mount Pleasant, by Professor D. C. Bell and Mr. Griffin from the Dominion office in Brantford. On the evening of August 12, the professor tried a new experiment, having had an instrument made so that three persons could sing different tunes or different parts of the same tune into the instrument at the same time. The trial was perfectly successful, the different voices coming

Fig. 1.

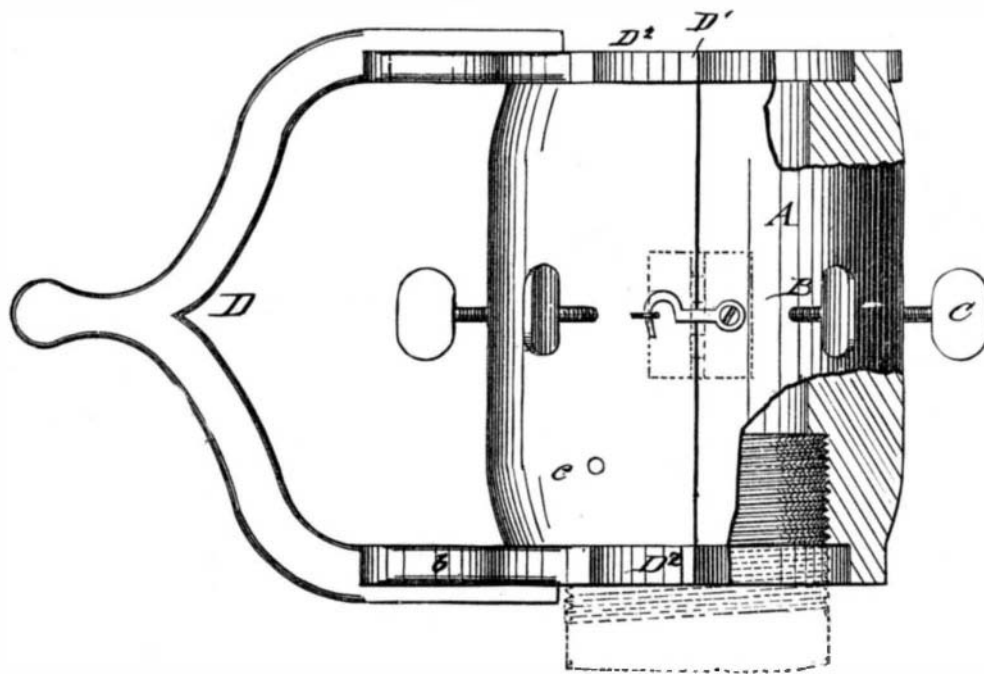
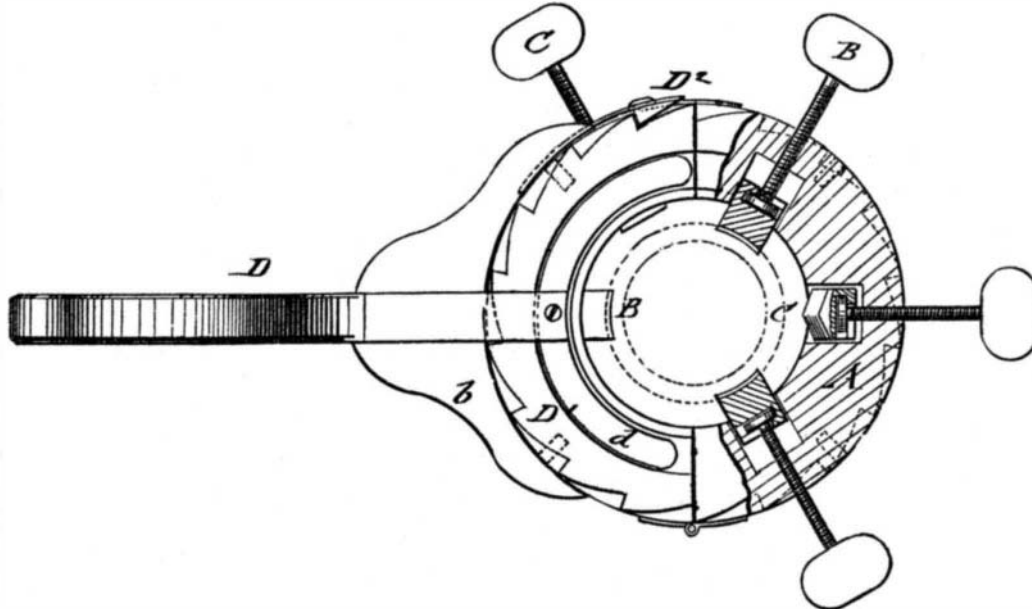
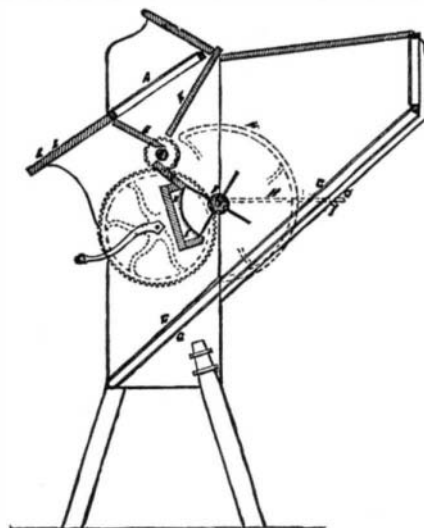

Fig. 2.



**EATON & LATHAM'S PIPE CUTTING AND THREADING MACHINE.**

down to the cylinder, E. The latter is made with four rows of pins, and revolves with velocity, spreading and separating the sand and gravel and throwing it against the screens, G G. These screens are placed one over the other. The roofing gravel and sand pass through the upper screen (which is made of half inch mesh or any other size needed) to the lower, which is six meshes to the inch, or any size required. The roofing gravel passes down between the legs, which are inclosed, and the sand through the fine screen. The coarse gravel passes down in front of the machine. H is a wrapper or beater, which strikes eight times with every revolution of the crank, against the under part of the screens, and loosens any sand that may stick to the screen. K is a feed



board which can be raised or lowered to regulate the flow of sand to the machine. L is a shelf for carrying off coarse gravel. A single screen is made of four meshes to the inch, or any other size required, to be used for screening sand when roofing gravel is not wanted, allowing all the gravel to pass down in front of the machine.

distinctly over the wire at the same time, so that they could be separately distinguished by the listener. The practical exemplification of the lately discovered system of telephony made by the professor afforded much pleasure and information to those present.

### Correspondence.

#### The Moon's Longitude and Solar Retrograde Motion.

To the Editor of the Scientific American:

In the SCIENTIFIC AMERICAN SUPPLEMENT (page 492, volume I), you state that a paper by Professor Newcomb, on "Inequality of the Moon's Longitude," was read at the June meeting of the Royal Astronomical Society, and that several of the more notable members of that scientific body expressed themselves as being at present quite unable to tell the cause of the phenomenon. Allow me to advance the following, which, I think, points to the cause.

The sun, his planets, and their several satellites are all distinct members or wheels of the great, grand celestial machine called the solar system; and unless we look upon the whole as a machine, and trace the effects which the retrograde motion of the largest one has upon the smaller ones, and these upon the smallest ones, we shall never be able to tell the cause of the phenomenon now under consideration, nor the cause of kindred phenomena in other moons; for they all move more or less ahead of their times while in one side of their respective orbits, and lag behind while on the other side, just as the earth herself and every other planet does, and must do, although practical astronomy has not yet discovered the facts.

To explain. We take the sun, or main wheel, first: His orbit is to be considered the rim of the wheel; the center of his orbit, the center of the wheel; and he (the sun) fixed, as it were, on or in the rim. That wheel turns on its axis retrogressively; and the rim, and the sun, of course, retrograde at the rate of nearly  $50\frac{1}{2}''$  annually. Now, by virtue of the earth being carried retrogressively by the sun, she, too, retrogrades annually, as it were in her own orbit, nearly  $50\frac{1}{2}''$ . Could we stand at the center of the sun's orbit, and view clearly the longitude of the earth at the moment she reaches  $180^\circ$ , we would find that she had fallen behind her sidereal place in the heavens, that is, the point at which she was when she came to  $180^\circ$  the previous time, say  $50\frac{1}{2}''$ ; and when she came to  $0^\circ$ , she would be  $50\frac{1}{2}''$  retrogressively in advance of where she was at the moment she came to the same point in her orbit one exact year before. In other words, she would be behind time on one side of her orbit, and in advance of time on the other side of it.

And it is exactly so with the moon. In one exact terrestrial year the moon retrogrades in space to the same exact amount; or, in other words, her orbit, as a whole, is carried retrogressively in space nearly  $50\frac{1}{2}''$ , annually, or about  $4''$  for every revolution she makes. It seems easy to see, then, that, in consequence of her retrogression in space, caused by the retrograde motion of the sun, she must be behind time, while on that side of her orbit which is outside of the sun's orbit, and *vice versa*.

I submit the above to the consideration and amendment of the wise and learned.

Gloucester City, N. J.

JOHN HEPBURN.

#### Professor Crookes' Radiometer.

To the Editor of the Scientific American:

On page 116 of your current volume, Mr. Joseph Delsaux, of Louvain, Belgium, presents some interesting experiments upon the radiometer. As I have not a radiometer at hand, I assume that the described tests were correctly made; and feel that there is good cause to suspect a coaction of forces to move the electrometer vanes. Could it not be settled beyond a doubt by charging the radiometer globe from an electrical machine, to the same tension and with the same kind of electricity as the globe contained after being submitted to the radiation of the sun or any source of light, and then ascertain if the action of the radiometer were the same?

Some other phenomena could be investigated in this connection. For instance, it is well known that selenium varies in electrical resistance from 15 to 100 per cent, inversely as the intensity of light to which it is subjected. It is also an established fact that on telegraphic circuits the speed of signaling is decreased during the middle portion of the day, and improved at night. Mr. R. S. Culley, the well known English electrician, called attention, in 1872, to this retardation, and said that the cause was not clear, but attributed it to "the ordinary diurnal variation of earth currents and to the increased resistance of the wires from increased temperature." As Mr. Culley has drawn no line between warm and cold weather, it would be well for Mr. Delsaux and other skillful experimenters to take the matter up, and apply the electrometer to things in the light and in the dark. We may perhaps thus be informed of what we are seeking to know.

Chicago, Ill.

F. W. JONES.

#### Test Colors.

To the Editor of the Scientific American:

In No. 7 of your current volume, I notice a report of a discovery of new test colors from the iris and violet. I have found the blue convolvulus major, or morning glory, of considerable practical value as a test for acids and alkalies. In the first place, the flower itself is very sensitive, indicating the trace of nitric acid in rain water after a thunderstorm. The flowers show red spots wherever the rain water has

wetted the surface after a shower during the night. A few of the flowers rubbed in a glass of water will give a bright blue liquid, which will instantly redden if a drop of nitric or other acid be put in; and the blue will be restored by neutralization. But if the alkali is much in excess, it will turn green and return to blue on neutralizing again. Water colored by the red convolvulus will turn blue on the addition of an alkaline salt, but is not so sensitive as the blue.

Milledgeville, Ky.

M. W. VENABLE.

#### Some Notes on Potato Beetles.

To the Editor of the Scientific American:

It is not often that you are caught napping, and you are more apt to be so caught when lounging in the field of natural history than in any other. In your issue for July 29, you copy an article from the SCIENTIFIC FARMER, entitled "Facts about Potato Beetles," in which, among the prominent statements offered as "facts," we are told that the potato beetle (by which of course is meant the well known immigrant from Colorado, and not any of the other beetles that affect that plant) does not fly till night and does not eat. Both these statements are incorrect. The *doryphora* 10-lineata, like most of the species of its family, flies readily in the daytime, but not at night; and it feeds freely upon the various plants of the nightshade family besides the potato, and sometimes does considerable damage in spring long before the larvæ appear; though it is not as voracious as these and seldom abounds on a plant to the same extent. Reasoning from his "facts," the writer of the article goes on to say that "any mode of destroying the beetle, practised by the farmer here and there, is only lost time \* \* \* therefore let the beetle alone"—an erroneous deduction naturally following from the erroneous premise, and very unsound advice. It is in fact all important, from the practical view, to destroy the first beetles and thus prevent the laying of eggs and the subsequent injury; for while it is true that they may continue to fly in from neighboring fields, the fact nevertheless remains that the more you kill the less you have. Many experienced farmers in this part of the country justly consider the destruction of the early beetles important enough to warrant the laying of traps before the potatoes begin to put out of the ground; and they do this by dipping slices of the tuber in Paris green and laying them about a field where no domestic animal can get at them.

There are other errors in the article in question, but of minor importance. For instance, every one who has had much experience knows that the third or last brood of beetles is fully developed and flies around for weeks or even months before seeking winter quarters, and that they hibernate in the perfect state, ready to awaken in the spring and fly about again for a few weeks before procreating. The species is, also, northern, not southern, in habitat, and, while spreading east along certain parallels, has not extended south. The talk, therefore, about the insects remaining dormant through the winter merely "because the temperature is too low to perfect the insects," and about the probability that, if they reached a tropical climate, their "transmigration (transformation) will be uninterrupted"—is "misty," to say the least. The hibernating state is induced not alone by cold, and many insects prepare for it and cease multiplying months before winter sets in; and *doryphora* is one of them.

St. Louis, Mo.

C. V. RILEY.

[For the Scientific American.]

#### THE CALORIMETER OF THE MASSACHUSETTS INSTITUTE OF TECHNOLOGY.

Among the drawings displayed by this institution at the Centennial is one of the calorimeter used in the mechanical laboratory of the school, and a description of it by the professor of engineering may be found on one of the tables. A courteous attendant is usually on duty also, who takes pleasure in answering the questions of visitors. Profiting by these sources of information, the writer has prepared a description of the apparatus, which will doubtless be of interest to engineers.

The general use of the calorimeter is to measure the quantity of steam condensed in it in a given time, and the amount of heat imparted to the condensing water by the steam. In this connection it is valuable for determining the quality as well as the quantity of steam evaporated by a boiler, the steam required per horse power per hour by an engine, the condensation in the cylinder, the total and latent heat of steam at different pressures, the transmission of heat by different conductors, and numerous other problems of a similar character. Its great value in teaching the students right methods of investigation will be obvious, and at the same time practical questions of importance to steam users can be examined. The calorimeter to be described was used by Mr. Dixwell in his experiments on condensation in steam cylinders, a notice of which will be found in the SCIENTIFIC AMERICAN for March 11, 1876.

The essential features of the instrument are a tank containing a condensing coil, a tank for the condensed steam, scales for determining the weights, and thermometers for ascertaining the temperatures. Steam enters the condenser, which is arranged so as to drain thoroughly, and after being condensed is discharged into a small tank where the weight and temperature are noted. The large tank is filled with water, the weight and temperature of which are noted at regular intervals. The small tank is closed at the top by a floating cover, secured to the edges by a rubber diaphragm. The large tank is also closed at the top, but provision is made for expansion by an expansion tank placed above, and having a floating cover. Each tank rests upon a pair of platform scales, and all connections to the tanks are made

by means of rubber pipes, which only change their direction slightly during an experiment, and consequently do not sensibly affect the weights. The large tank has a circulating pump which is worked at intervals during an experiment, so as to make the temperature of the condensing water uniform in all parts of the tank. To illustrate the use of the apparatus, suppose the exhaust pipe of a steam engine to be connected with the condenser, and that the consumption of steam per indicated horse power is to be determined. The large tank is filled with water, until the cover in the expansion tank floats, and the weight and temperature of the water are noted. The engine is then started, and at regular intervals indicator diagrams are taken, and the weights and temperatures of condensing and condensed water are noted, the temperature of the water in the large tank being equalized by the aid of the circulating pump before it is recorded. The result of a series of operations shows that a certain weight of steam of a known pressure imparts a definite amount of heat to the condensing water, and from these data the quality of the steam can be calculated.

The reader is doubtless familiar with other calorimeters, as they are frequently used by engineers. A large one was employed for two years at the fair of the American Institute in tests of steam boilers, the weight and temperature of the condensed water being noted, and a somewhat similar apparatus was used on a later occasion for testing the amounts of steam required for several rotary engines. The difference between these calorimeters and the one described above seems worthy of notice. In the one case the calculations are made by observing the successive changes in temperature of a definite weight of water which is used throughout the experiment, and in the other the condensing water flows away continually, so that the temperature of the discharge does not vary much during a test. It will be seen that, where a definite volume of water is heated by condensing steam, the amount of heat thus measured is not all that has been given up by the steam, since some of the heat is absorbed by the apparatus; while in the other form of calorimeter, if a definite temperature is reached before commencing an experiment, and is afterwards maintained, no more heat will necessarily be absorbed by the apparatus. Of course, in the form of apparatus used at the Massachusetts Institute of Technology, the amount of heat absorbed under various conditions might be determined, and the necessary corrections applied. Perhaps this has already been done, but it does not appear in the account given by the professor of mechanical engineering, who is quite minute in describing the tests of gages and thermometers. It may be, however, that the correction would generally be unimportant.

As appears from the descriptions of the use of this apparatus, the students are well drilled in some special tests of testing apparatus. This is one of the most important points in the engineer's practice, and it seems to be duly appreciated at the school. Experience shows that physical apparatus cannot be made free from defects, but that, if the amount of error is determined, corrections can be applied which will give accurate results.

R. H. B.

Philadelphia, Pa.

#### A Useful Tree.

Mr. Morgan, an English consul resident in Brazil, cites, in a recent report to his government, the carouba tree, a species of palm (*copernicia cerifera*) as one of the most valuable vegetable productions of the country. It flourishes without culture at Bahia, Rio Grande do Norte, and other well known localities, resists drought, and always appears green and luxuriant. Its roots possess properties similar to those of the sarsaparilla. The trunk furnishes a superior fiber. When the tree is young, it yields wine, vinegar, a saccharine matter, and a species of gum closely resembling sago. Its wood is excellently suited for the manufacture of musical instruments, as well as for tubes and conduits for water. The pulp of the fruit is very palatable, and the oily nut roasted and pulverized is a good substitute for coffee. The trunk also yields a flour similar to maizena. With the straw, hats, brooms, and baskets are made, and over half a million dollars worth of it are exported to England yearly. Lastly, a wax, used in the manufacture of candles, is extracted from the leaves.

#### The Cause of Asphyxiation.

Dr. Blandet, in the French *Gazette Medicale*, denies that carbonic acid gas has any toxic effect in cases of asphyxiation, and claims that it simply suffocates by filling the lungs to the exclusion of oxygen. Persons partially asphyxiated by carbonic acid gas can usually be restored by inhalations of oxygen. The true cause of bad air poisoning, Dr. Blandet thinks, is carbonic oxide, which is disengaged prior to carbonic acid. This does not diffuse itself in the blood like the latter, but remains and destroys the hemoglobine and the hematine.

The best remedies are not only inhalations of oxygen, but friction of the skin with oxygenated water and decomposable oxides, such as those of manganese and of cadmium. It is also suggested that sulphurate of ammonia, administered hypodermically, might decompose the carbonic oxide.

A CANADIAN sportsman declares that the speckled trout in Ontario have been killed by warm water. The woods have been cut down, and the sun, shining upon the water from morning till night, heats the streams. He asks the farmers to plant willow limbs along the water's edge to shade the brooks and give the trout a chance—to be caught by anglers.