

IMPROVED TURBINE WHEEL.

The object of the invention herewith illustrated is to overcome the well known defect of the turbine, namely, a diminished percentage of power when less than full gate is used. To this end, the wheel is made adjustable, and may, without variation of its assigned proportions, by a combined inner and outer gate, have its capacity altered in accordance with the changes of the gates and chutes, and with regard to the power required or modifications in the head. This is claimed to be accomplished without loss in coefficient of useful effect. Fig. 1 represents the wheel complete, and Fig. 2 is a section, showing the inner gate broken away and partly open.

To the crown plate, A, which is cast on the hub, are bolted the annular plates, B, to the lower of which are attached a series of partitions, C, Fig. 2, which form the curved channels or bucket spaces. The casing consists of a dome, as shown in Fig. 1, supported on a curb whose bottom flange rests on the foundation and supports the spider, D, Fig. 2. An adjustable step rests on the center of the spider and forms the lower bearing of the main shaft. The upper flange, E, of the curb is indented, and, inclining downward outwardly, forms the bottom of the chutes. From the edge to the vertical part of the curb extend a series of slots, corresponding in shape to the chute guides, F, and through which the said guides move freely in a vertical direction (dotted lines) when the gates are elevated or depressed. The dome is secured to the curb by pillars, and its bottom edge is beveled inward to repel any obstacles that may collect on the upper side of the gate rim. The outer gate consists of a vertical ring, with a small flange at the top and an indented rim, G, below, having a narrow flange projecting slightly inward under the inner gate. This flange and the edge of the curb beneath it form the shutting surfaces of the outer gate. The width of the small upper flange is proportioned so that the pressure of water under it may counterbalance the weight of the gate and its appendages. It slides on the inner surface of the dome and is packed watertight. The rim forms the upper surface at the mouth of each chute, and it curves downwards so as to direct the water into the chutes and permit sediment to be carried off.

The inner gate, H, is connected by a perforated plate to the hub. Its bottom is made with slots corresponding to the partitions, C, not fitting watertight, however, but having clearance enough to admit water above the plate.

At I is a screw rod, supported in a frame as shown, and operated by the hand wheel.

This fits into a corresponding female screw in the hub, and is attached to a spider from which depend rods, secured to the flange of the outer gate. To the hub of the spider, by a ball and socket connection, is attached a rod, J, which passes within the tubular shaft, and is secured to the hub to which is attached the plate of the inner gate, I. The rotation of the hand wheel thus elevates or depresses both gates simultaneously; and the ball and socket connection permits the inner

wheel by friction against it. In order to facilitate the discharge, the lower plate, B, which forms the bottom of the buckets, inclines downward at its inner edge. This form of bucket is applicable to both inward and outward discharge wheels. The guides, F, are arranged around the wheel, so as to throw the water to the center. Through these guides and the other surfaces bounding the chutes, the elevation or depression of the outer gate increases or diminishes, not merely the gate area at the opening and shutting edges, but the entire capacity of the chutes.



WALTON'S TURBINE WATER WHEEL.

The shallow grooves, shown cut in the tops of the partitions, C, permit water to pass from one bucket into another over the diaphragm, to balance the pressure from below, and keep it equipoised at any elevation in the bucket. The bolt heads, by which the upper plate, B, is fastened to the crown plate, form stops, which prevent the diaphragm from coming into contact with said plate, and preserve more or less space and water passage at all times in the upper part of the bucket.

It will be observed that this arrangement constitutes a device which operates both outer and inner gates, which enlarge and diminish alike the chute and bucket spaces simultaneously, while the wheel is in motion or at rest. The wheel is thus kept properly proportioned and the inlet current maintained constantly at the same angle. The result, as already stated, is the full percentage of power at all elevations of the gate.

Patented July 14, 1874. For further information, address the inventor, Silas Walton, Moorestown, Burlington county, N. J.

IMPROVED BALANCED SLIDE VALVE.

We illustrate herewith an improved balanced slide valve,

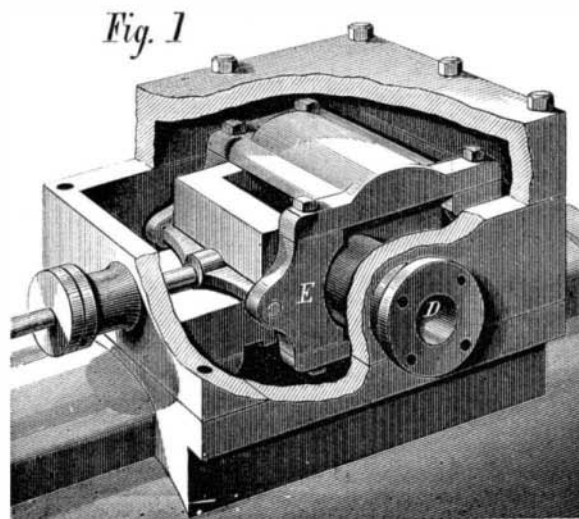

The principal advantages claimed are that there is very slight pressure of the valves on their seats, and that, through there being double steam and exhaust ports, the steam acts more rapidly on the piston, and is exhausted more rapidly, with less back pressure.

A perspective view, with the chest broken away to show the valve, is given in Fig. 1. Fig. 2 is a vertical section and Fig. 3 a plan view, the cover being removed. The steam ports, A, lead into the passages, B, Fig. 2, at each end of the cylinder. Each passage, therefore, has a double port. The exhaust ports, C, lead into a common exhaust, D. The two slide valves are constructed in the usual manner and are connected by bolts, as exhibited in Fig. 1, said bolts passing through projections on the valves and supports, E. Upon each bolt is a spring to permit the valves to open and discharge condensed water from the cylinder, thus preventing the bursting of the latter. As shown in Fig. 2, steam is entering on the right hand side.

The valve obviously is little subject to wear. It is especially adapted for engines the motion of which it is desirable frequently to reverse, as locomotives and hoisters, since the engineer is afforded control of the machine without requiring steam to be shut off. The valves and ports, being parts of the steam chest, are easily detached, and thus may be readily and economically repaired.

Patented April 7, 1874. For further information relative to sale of rights, territory, etc., address Messrs. Wisner & Strong Pittston, Pa.

Sinking of an Hotel into the Earth.

The St. Louis Journal relates the following occurrence, that happened in that city on May 12: "Considerable excitement was created in East St. Louis, yesterday morning, on the discovery that Belleville House, a two-story frame building, just south of the Pittsburgh Railroad and Coal Company's dike, near the southern limits of the city, had disappeared in the quicksand. The circumstances connected with the unusual occurrence are as follows: The house, which is used as a hotel, was built on piles, and but a few days before showed evidences of an inclination to sink into the earth. On Thursday night it sunk about two feet; but the proprietor, Mr. F. Decker, not apprehending anything serious, paid very little attention to the matter. On Friday night, the guests went to bed as usual; but at a late hour the clerk, Mr. George Huebner, discovered that the premises were getting rather unsettled, and gave the alarm. Before the inmates could realize what was going on, the building had sunk forty-eight feet, carrying with it ten persons. After considerable difficulty they were all rescued, badly frightened but not hurt. The back water from the river soon surrounded the place where the house stood, and would very probably have carried it away if the gable end, all that is visible, had not been securely fastened to terra firma. Mr. Decker's loss on the building is about \$6,000, and on furniture about \$1,990. The house was recently purchased

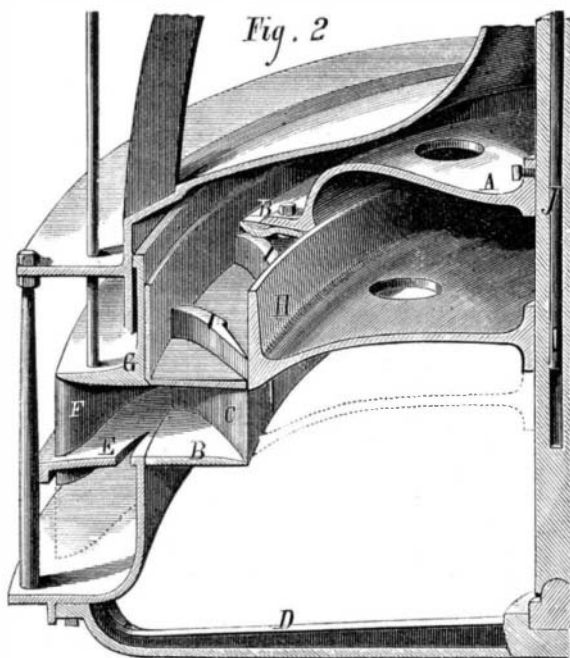

gate to rotate with the water wheel, while the movement of the outer gate is only vertical.

The impact side of each partition, C, is curved inward to a distance somewhat greater than the width of the chutes, and extends thence so as to form a smooth, continuous surface throughout its whole length. The convex side forms a thin edge with the concave side, and curves inward on a different center from the latter. A recess or offset is then produced, and the remainder of the partition is a thin-edged plate. The recess prevents the discharging current from coming in contact with the curved side of the partition after passing the annular point, so that the issuing liquid vein passes clear of the wall of the succeeding bucket, and does not retard the

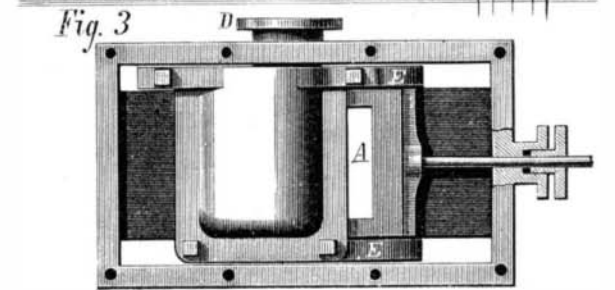
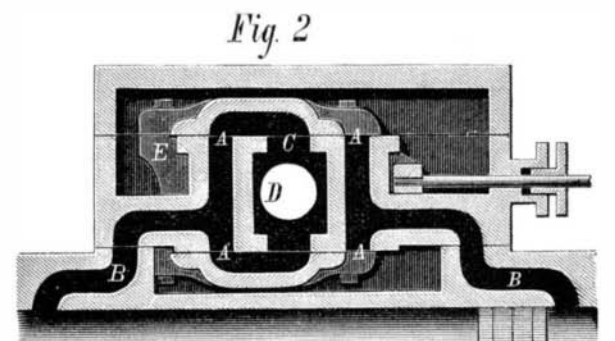

by the present proprietor; and in all probability it entirely disappeared last night, as very little of it was visible at a late hour."

Powder for Producing Ozone.

In order to produce artificial ozone, Mr. Lender makes use of equal parts of peroxide of manganese, permanganate of potash, and oxalic acid. When this mixture is placed in contact with water, ozone is quickly generated. For a room of medium size two spoonfuls of this powder, placed on a dish and occasionally diluted with water, would be sufficient. The ozone develops itself; it disinfects the surrounding air without producing cough