

**IMPROVED LEATHER AND CLOTH ENAMELING MACHINE.**

The annexed engravings represent a machine for enameling cloth and leather, which is capable of a great variety of useful applications, such as spreading waterproofing and other compounds on textile fabrics. The inventor gives the following description of the machine, as illustrated in the engraving. Fig. 1 is a view of one side; Fig. 2 is a central vertical longitudinal section; and Fig. 6 is a top view of a portion of the machine.

The cloth or other material to be enameled or to be covered with waterproof or other substance is wound around the beam or roll, *c*, and is then made to pass, by the power communicated to the machinery, under the bar, *d*, and over the top of the bar, *d'*, the corrugated, toothed, or grooved surface of the bars, *d d'*, serving to smooth and evenly spread to its full width the cloth or other material, which is then fed along over the rod or bearing, *r*, and below the hopper, *k*, from which the enameling, waterproofing, or other substance or compound is deposited upon the cloth or other material, and regulated in its delivery through an opening or throat in the bottom of the hopper, *k*, by the action of the sliding gate, *h*, which is raised or lowered by the operation of the lever arm, *l*. The cloth or other material is then carried along between the smooth rollers, *t t'*, which are kept moistened by the dripping of water or other liquid contained in sponges or other suitable substance held in the trough, *v*. The cloth or other material is then brought over the cushion, *H*, and under the blade, *F*, which is raised or lowered by the action of the lever arm, *E*, so as to accommodate itself to the thickness of the cloth, etc., which is then fed over the upper surface of the corrugated, toothed, or grooved bar, *d'*, and thence between the cushion, *H'*, and blade, *F'*, and is then carried between the smooth rollers, *x x'*, whence it is delivered and placed upon drying racks. The blades, *F F'*, serve to spread, distribute, and incorporate the enameling or other mixture evenly upon the entire surface of the cloth, etc., upon which it is firmly and evenly pressed by the action of the rollers, *t t'* and *x x'*. The bars, *d d' d''*, may, if desired, be arranged with heating chambers, and may have either the upper or under surfaces formed with corrugations, teeth, or grooves, and the cloth, etc., be made to pass over or under them, as may be required. Either one or more troughs, or one or more sets of rollers and blades, may be used. The invention may be operated by hand, steam, or any other suitable motive power.

Patented September 3, 1872, to Luther L. Allen, Hallowell, Me.

**IMPROVED PROCESS OF CAPSULING MEDICAMENTS.**

M. S. A. A. Limousin, of Paris, France, has patented, through the Scientific American Patent Agency (February 8, 1876), an improved mode of capsuling medicaments, by which druggists may furnish them in a neat and readily made up form to the public, to be taken in an easy and convenient manner. Disk-shaped wafers, *A*, of different sizes, according to the quantity to be enclosed by the same, are made with concave

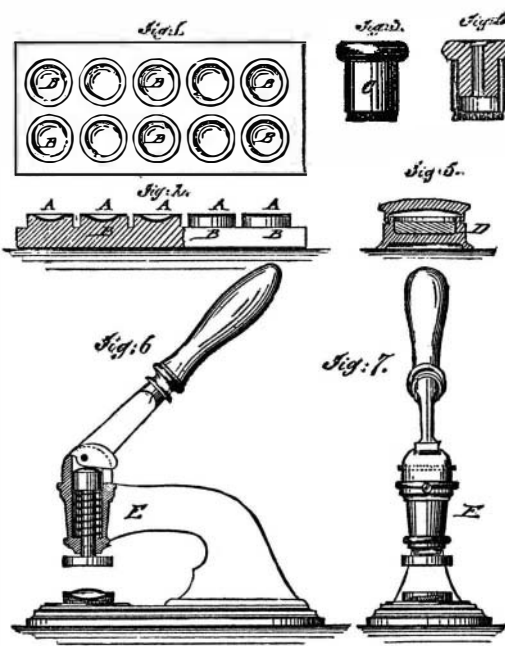

central parts, which may be at the same time embossed with the name, address, etc., of the druggist, and the name and quantity of the medicament contained therein. A number of concave stamped wafers are first placed on a series of concave disks, *B*, of the same size and shape, so as to fit exactly thereto, the disks forming the support for the wafers, which are then filled by a graduated measure with the exact quantity of the medicament. The outer edges of a corresponding number of wafers are then moistened by the device, *C*, which consists of a double metallic tube with

interior filling of suitable fabric that retains and distributes the water, taking it up by dipping it in a dish, *D*, with spongy material saturated with water. The main object of the dish and moistener is to supply only so much of the moisture as will be sufficient to produce the adhesion of the edges of the wafers when placed one on the other. The second series of wafers, when moistened at the edges, are then placed on those supplied with the medicaments and transferred with them to the lever press, *E*, to be firmly closed at the edges. The press, *E*, has concave metal disks, corresponding in size and shape to the wafers, so that only the edges are compressed, while the central part of the wafers

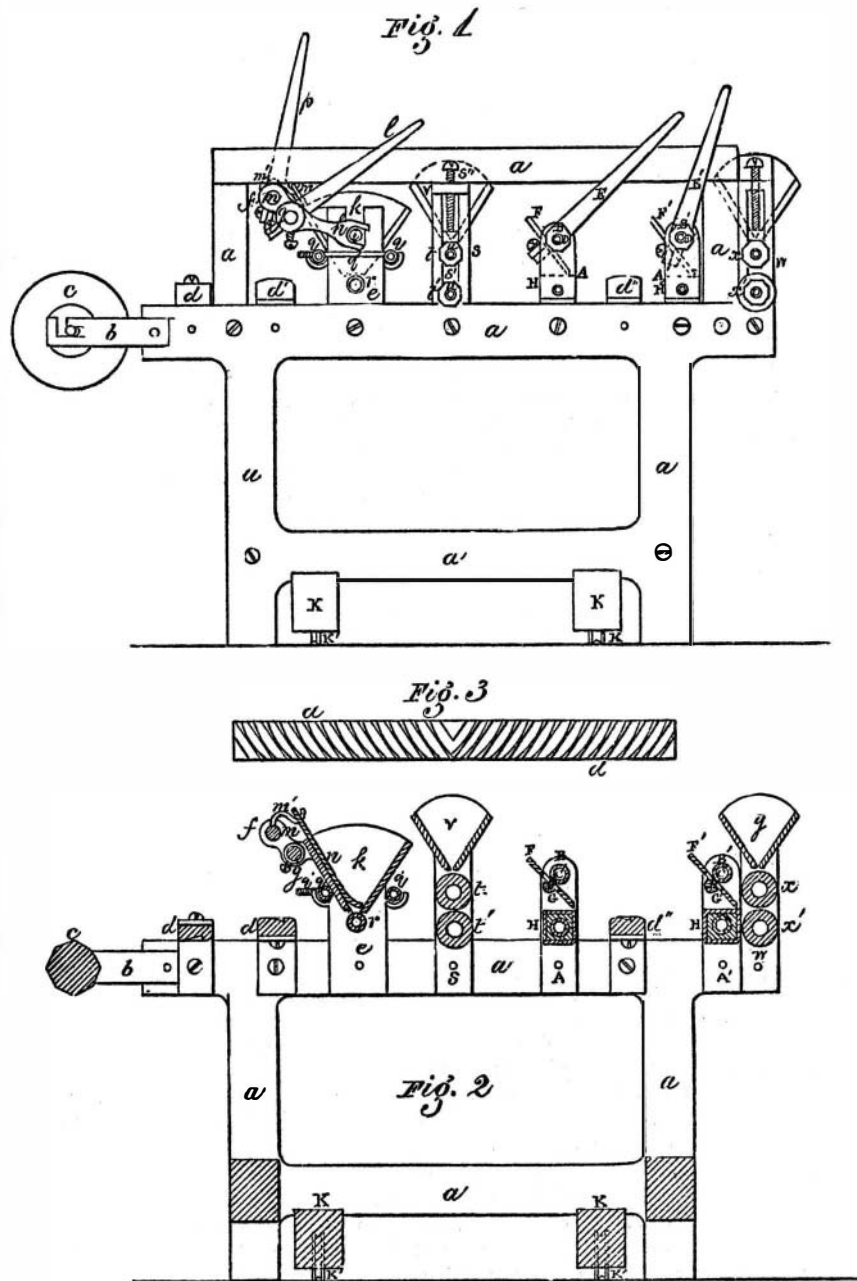

**ALLEN'S CLOTH-ENAMELING MACHINE.**

is not interfered with. The jointed wafers form a lens-shaped central space in which the powders are contained and held securely enclosed by the wafers.

Any medicament taken in the form of a powder may be made up in this manner, and kept on hand for any length of time without deterioration.

**IMPROVED ELECTRO-MAGNETIC DENTAL ENGINE.**

Mr. Elihu Pettit, of Philadelphia, has patented a simple contrivance for coupling a magnetic engine to a dental engine, for use instead of the foot power for driving it.

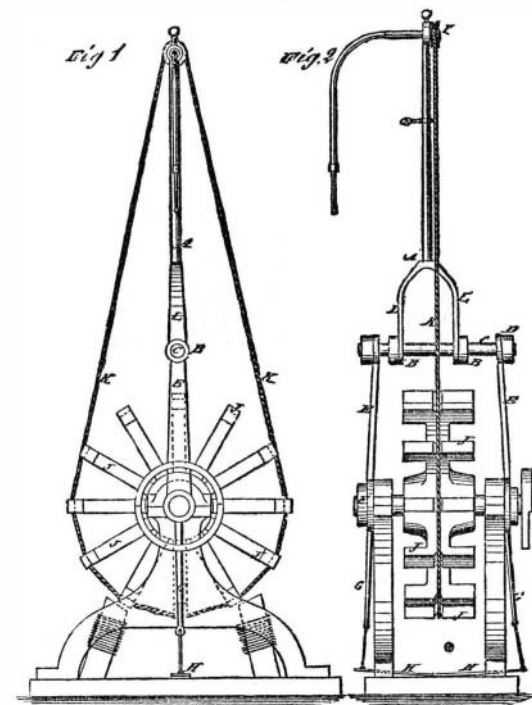

The armature wheel of the magnetic engine is employed in the place of the driving wheel of the foot power for running

the band, and the standard of the dental engine is mounted on the shaft of the armature for its support. Fig. 1 is a side, and Fig. 2 a front, elevation.

*A* is the crotched standard of the dental engine, which is cut in two just below the bearings, *B*, for the shaft of the driving pulley. The latter is worked by the foot treadle, and fits on a shaft, *C*, which is mounted in bearings, *D*, of standards, *E*, secured to the projecting ends of the armature shaft, *F*, with extensions, *G*, to the base, connecting with a spring, *H*. This serves to keep the standard upright, but at the same time allows it to vibrate for swinging the top forward and backward, as may sometimes be required in the manipulation of the tools. The shaft pulley, *I*, is thus brought directly over the armature wheel, *J*, so that it may serve for the band wheel, for which *V* notches are made in the armature for a round band, *K*, and flat bottomed notches for a flat band.

In making new machines for connection with a magnetic machine, the crotch, *L*, of the standard will be extended so as to serve for the standards, *E*, and fit the bearings, *D*, on the armature shaft, thus dispensing with the shaft, *C*, which is only necessary in the connection of dental engines made for foot power.

Patented through the Scientific American Patent Agency, February 22, 1876.

**Lightning Rods.**

The committee appointed by the Prefect of the Seine to superintend the construction of lightning conductors in Paris has been changed into a permanent one. A sum of \$40,000 has been appropriated by the municipal council for reconstructing all the lightning conductors in Paris, or at least all those which may be found defective or inefficient. This sum is a first instalment, as the whole of the work, it is supposed, will cost \$250,000, although the committee do not recommend the use of copper conductors.

Until the appointment of the committee, lightning conductors were constructed by ordinary blacksmiths, under the superintendence of architects who knew nothing of physics. A competitive adjudication took place recently, between a number of competent electricians, for the construction of all the lightning conductors on the Paris municipal monuments. The successful competitor is M. Grenet, the well known electrician. A list of instructions with seventy carefully drawn provisions has been published. The continuity must be tested yearly, and the contractor will be paid by instalments; so that his claim will be cleared up only when the efficiency of his work shall have been tested during a certain number of years. The platinum cone has been abolished and replaced by a copper cone. The quality of the iron, as well as of the copper and solder, is to be tested by chemical analysis. The insulation of rods has been abolished as being useless. The committee has diminished the diameter of protection area, which was supposed to be twice the height, and has reduced it to 1.45. The consequence is that rods are to be multiplied — *Nature*.

**NEW PROCESS OF PRESERVING WOOD.**

The annexed engraving illustrates a recently patented pro-

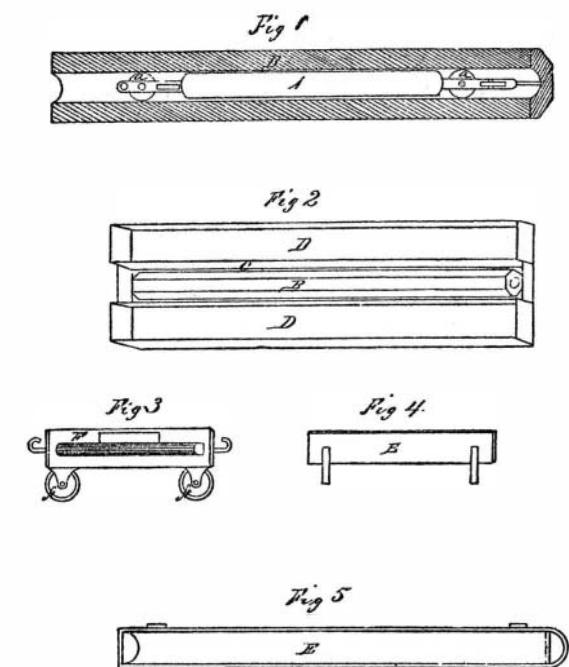

cess of saturating wood with any liquid which will fill the pores of the wood and solidify on cooling. The method consists of heating the wood till all moisture is evaporated and the pores opened, and then plunging the wood while hot into a suitable liquid. Fig. 1 shows a bored section of a pump log, *B*, cut in half longitudinally; and *A* is the heating apparatus, having a coal fire within it. It will be seen that the cylinder, *A*, is kept from immediate contact with the bore of *B* by the rollers, *a*, which are slightly larger than the cylinder, *A*. The heating cylinder can thus be