

**TESTING BOILERS.**

An English firm (Messrs. Howard & Co., of Old Hill, Worcestershire) is now making boiler shells with welded seams, a form of construction involving some difficulty in manufacture, the trouble of which will be amply repaid by the improvement in strength and durability of the boiler. Hydraulic pressure is used for testing the soundness of the welds, and for this purpose Messrs. Tange Brothers, of Birmingham, have designed and constructed the machine herewith illustrated. It is capable of testing shells up to 4 feet in diameter and 35 feet long, at a pressure of 200 lbs. to the square inch.

The appliance, the engraving of which we select from *The Engineer*, consists of a fixed hydraulic cylinder, 12 inches in diameter and of 12 inches stroke, connected to a traveling head by rectangular wrought iron bars, 5 inches by 2½ inches, pierced with cotter holes of 11 inches pitch; the platen attached to the hydraulic ram slides along the bars. When a boiler shell is to be tested, the traveling head is run out of the way along the line of rails, and the shell is run in on a truck, the head is brought back to its place, and the cotters are inserted in the nearest cotter holes. Pressure is then applied to the cylinder by means of hydraulic pumps; the ram forces the platen against the end of the shell, and the joint is thus made tight, ready for testing. The shell is then filled with water from a tank by means of a flexible hose inserted into a passage in the platen, while the air escapes by the tube, marked B, in the traveling head; this tube is made to slide diagonally, so as to suit any sized shell. The tube is then closed by means of a cock, and the test pressure is applied by the hydraulic pumps.

The boiler seams are welded by means of a gas furnace placed over them; and special machinery has been made for planing the plates, bending them into the form of tubes, and facing the ends of the latter, as well as for testing them by the machine now under notice.

**ATKINSON'S IMPROVED DESK.**

Any person that has spent an hour or two bending over a sitting desk, steadily writing, knows what a wonderful relief is experienced when he can transfer his work to an upright standing desk and straighten the painful stitch out of his back. To afford this relief, and to add many conveniences not heretofore embraced in a single desk, are the objects

Fig. 1

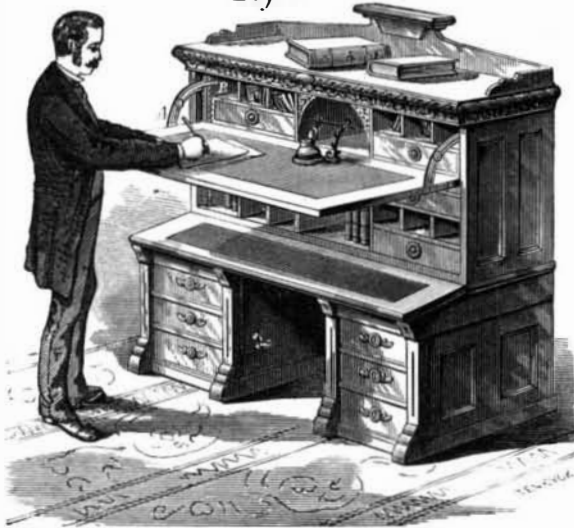

of the invention illustrated herewith. This desk is readily changeable from a sitting to a standing desk, or vice versa, by simply raising or lowering the table, which can be adjusted to any height; and besides, it can be placed at any angle desired. The movable table is pivoted to sliding pieces which travel in vertical guides on each side of the frame. Its weight is balanced by metal counterpoises which are se-

Fig. 2



of the invention illustrated herewith. This desk is readily changeable from a sitting to a standing desk, or vice versa, by simply raising or lowering the table, which can be adjusted to any height; and besides, it can be placed at any angle desired. The movable table is pivoted to sliding pieces which travel in vertical guides on each side of the frame. Its weight is balanced by metal counterpoises which are se-

cured by chains to the upper part of the slides, which chains pass over pulleys, so that the counterpoises hang inside the desk out of sight. The curved arms, A, which support the outer portion of the table, are also secured to the slide. These arms serve as guides for a third arm, B, which has projections on its inner end which engage in the rack teeth shown in Fig. 1, so as to aid in holding the table in whatever position it may be adjusted. The appearance of the desk with the table closed is shown in Fig. 2.

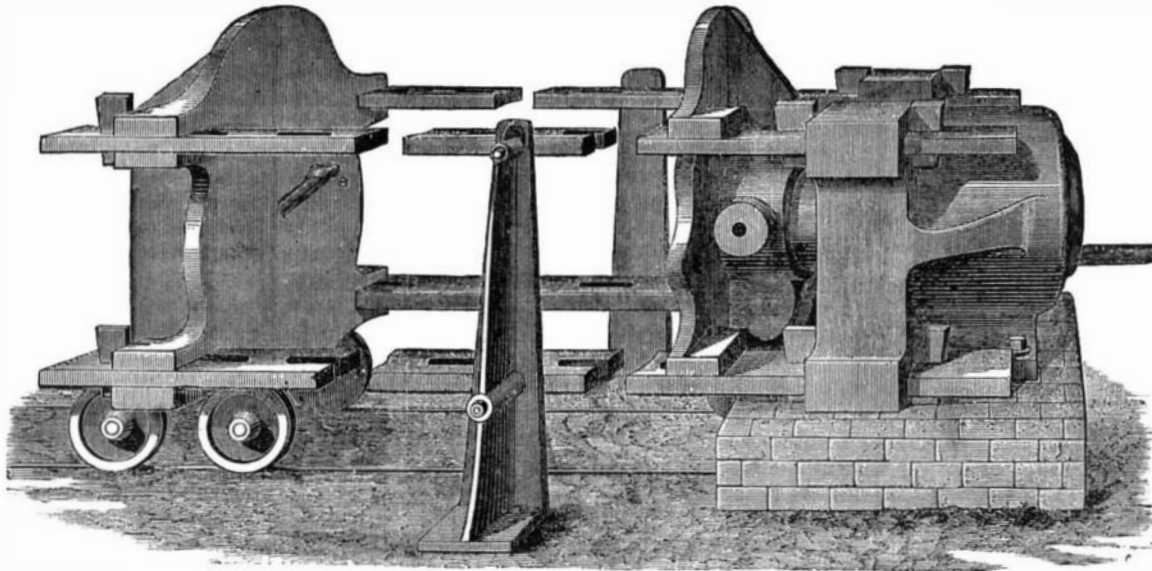

**HOWARD & CO'S BOILER TESTING MACHINE.**

The invention has a compact and ornamental shape, rendering it a handsome article of furniture for the library. Patented through the Scientific American Patent Agency, March 7, 1876. For further information relative to rights

The board which indicates danger, in moving, excites an electric current which leads to an apparatus placed in contact with the locomotive, and which produces a loud whistle. As soon as the indicator no longer indicates danger, the current is intercepted, and the locomotive may come in contact with the apparatus without causing a whistle. These experiments have been made during snow, and have invariably succeeded, the warning being given at a sufficient distance to allow of a train, running at full speed, being pulled up in time.

Fig. 3

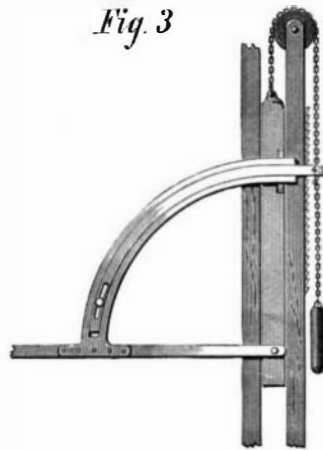

to manufacture, etc., address Chas. A. Atkinson, 2 Clinton Place, New York city.

**IMPROVED MUCILAGE BOTTLE.**

George R. Wight, of New York city, has recently invented a mucilage bottle, so constructed that the mucilage may be applied without a brush or any detached instrument. The bottle has a metallic cap, provided with an S tube and sponge.

A represents the bottle or cup; and upon the neck of the bottle, A, is formed a screw thread to receive the screw thread formed upon the inner surface of the flange of the metallic cap, B. In the center of the cap, B, is formed a hole, in which is secured the upper end of the small metallic tube, C.

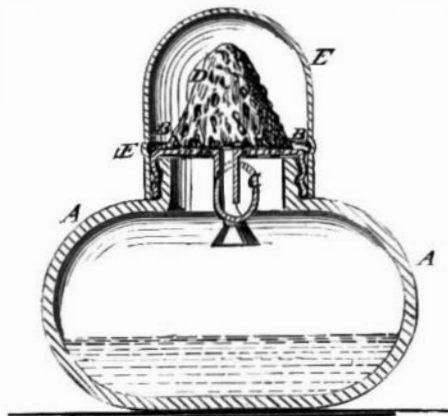

The tube, C, is bent into an S shape, so as to prevent the air from entering the bottle, and to keep the mucilage close to the sponge. D is a sponge cut into a tapering or conical form, the base of which is secured to the cap, B, by sewing, small holes being formed through the cap for convenience in securing the sponge in place. E is a cap, made of such a size as to cover the sponge, D, without touching it, which fits snugly and airtight upon the outer surface of the cap. In using the device, the sponge should be kept moist with water to enable the mucilage to pass through it freely. To apply mucilage, the cap, B, is removed, the bottle is inverted, and the sponge, D, is rubbed over the place to which the mucilage is to be applied, care being taken to replace the cap, E, to prevent the sponge from becoming dry and stiff.

**French Railway Signals.**

The Paris correspondent of the London *Times* says: "The French Minister of Public Works has addressed a circular to the railway companies, calling their attention to an apparatus designed to prevent the terrible accidents resulting from the inefficiency of danger signals. The question is of immediate interest on account of the lamentable accident at Abbot's Ripton, and the ministerial circular deserves, therefore, the greatest publicity, I wished, before transmitting it, to obtain information personally as to the efficiency of the system patronized by M. Caillaux. The results communicated to the companies by the circular may be considered conclusive, and seem destined to make up for the inadequacy of optical signals, which are naturally thwarted by fog or by a sharp curve, an inconvenience which it has been attempted to remedy by fog signals. In England a mechanical contrivance has been devised putting in motion a rod which, being struck by the engine, produces a whistle; but the recent accident has proved that this device is not infallible. The system indorsed by the Minister of Public Works seems, on the other hand, to meet every objection. It can be placed at any distance, as it acts simply by laying down a wire

it, to obtain information personally as to the efficiency of the system patronized by M. Caillaux. The results communicated to the companies by the circular may be considered conclusive, and seem destined to make up for the inadequacy of optical signals, which are naturally thwarted by fog or by a sharp curve, an inconvenience which it has been attempted to remedy by fog signals. In England a mechanical contrivance has been devised putting in motion a rod which, being struck by the engine, produces a whistle; but the recent accident has proved that this device is not infallible. The system indorsed by the Minister of Public Works seems, on the other hand, to meet every objection. It can be placed at any distance, as it acts simply by laying down a wire

**NEW FUSIBLE BOILER PLUG.**

The annexed engravings, taken from the *English Mechanic*, represent a new fusible plug, which is intended to act as an efficient safeguard against boiler explosions. A bulb of gun metal, C, is provided with a screw shank, whereby it may be screwed into the top of the fire box. Through the bulb passes an inclined tapered tube, D, so that the out-

FIG. 1.

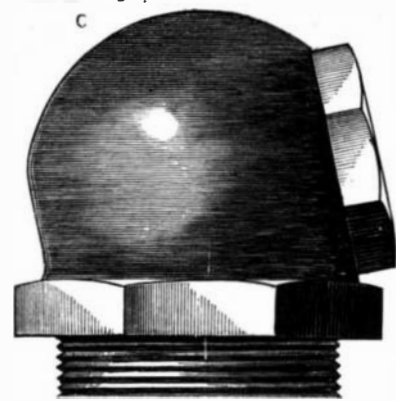

er surface of this tube and the inner surface of the bulb are subject to the heat of the fire, while the exterior of the bulb and interior of the tube are surrounded by the water in the boiler, which circulates through the latter. The tube, D, is slotted, and the slots, E, are filled with soft metal, which,

FIG. 2.

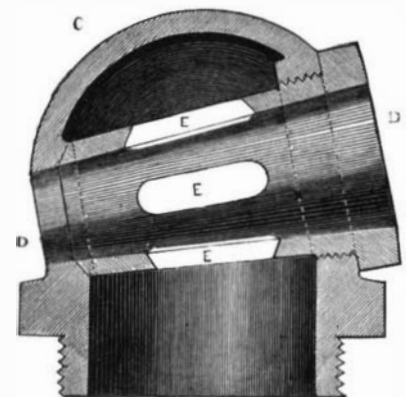

so long as the tube is full of water, is thereby kept from melting; but should the water in the boiler fall below the level of the tube, then the heat of the fire melts the fusible metal, forming apertures through which the steam rushes, thus relieving the boiler of pressure and at the same time putting out the fire. The device is the invention of Mr. T. J. Smith, of North Bow, England. Fig. 1 is a perspective view, and Fig. 2 is a vertical section