

American Grape Vines in France.

Mr. C. V. Riley, State Entomologist of Missouri, has lately returned from France, where he has been on a tour of inspection among the grape-growing regions. He was every where received and treated like a prince, dinners were given in his honor, and every possible attention shown to him in public and in private.

The particular reason for these civilities is the fact that Mr. Riley was the first to call the attention of the French to the fact that a simple remedy for all their troubles in connection with the grape vine disease was the substitution of certain species of American vines, by him named. These, he affirmed, would yield good wine in France and be free from the pest.

Some of the wine growers tried the experiment, which was continued the next year and that following; and the success has become so well established that extensive orders have now been sent to this country for vines. In fact it is believed the demand from France will be so great that our nurserymen will be unable to fill the orders for exportation this season. Mr. Riley saw plantations of American vines flourishing in France, where the native vines had been utterly destroyed.

A NEW CIRCULAR COMPASS.

M. Emile Duchemin substitutes for the ordinary compass needle two concentric circles, A B, in the annexed engraving, connected by a crosspiece, C, of aluminum or other metal. The maximum of magnetization starts from the N. and S. poles, and decreases to the neutral points, *n n*, as is indicated by the dark shading on the circles in the illustration.

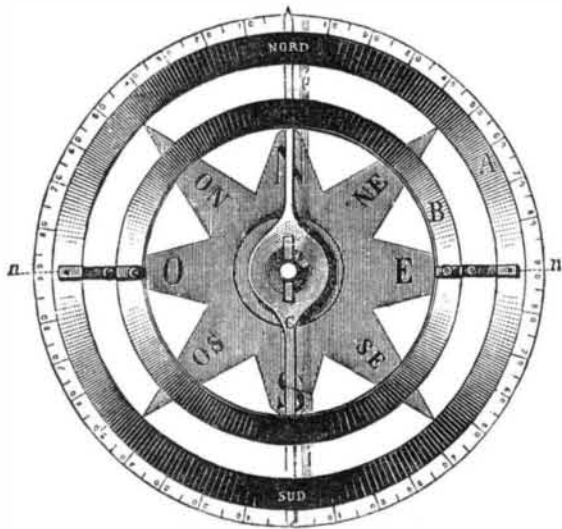

This compass is said to be much more sensitive than the needle, to be less affected by rolling of the ship, and to be much less sluggish than the liquid compass. These facts were adduced by recent French naval tests of the instrument in comparison with compasses of the usual construction.

Centennial Notes.

About \$3,500,000 have been subscribed toward the building fund, leaving a deficit yet to be made up, according to the reduced estimates, of \$2,000,000. This is exclusive of the cost of Memorial Hall (\$1,500,000), which is guaranteed by Philadelphia and the State of Pennsylvania, over and above their subscription. The latter amounts to \$3,575,000 out of the \$3,500,000, leaving \$925,000 as representing the total received from the balance of the Union thus far.

France wants special laws enacted by Congress in order to protect her exhibitors from piracy of their inventions by the "grasping Yankees." The French say that they passed such enactments for the benefit of contributors to the 1867 show and that now we should go and do likewise. If we remember rightly, the French laws did not prevent sundry grasps of American inventions at the 1867 Exposition, and exhibition of the same in French shop windows, for sale, while the owners waited and sought for redress which they never got. We have no illiberal policy which prevents foreigners taking advantage of our patent laws, and thus securing full protection for their ideas with as much facility as our own citizens; and such laws we think will be found to answer every purpose of preventing piracy, without any additional legislative tinkering.

The Director General of the Centennial has issued the following rules for the information and guidance of exhibitors.

The space granted to an exhibitor within the building is available floor space, exclusive of the intermediate passages between the exhibits.

There will be no charge for space, but all platforms, counters, ornamental partitions, show cases, and appurtenances must be erected at the expense of the exhibitor; but they must not exceed the following heights without special permission from the Chief of Bureau:

Show cases and partitions: Fifteen feet above the floor.
Counters: Two feet ten inches above the floor, on the side next the passage way.
Platforms: One foot above the floor.

Exhibitors have the privilege of placing railings of approved design around the space allotted to them, of the uniform height of two feet six inches above the floor level. The floor space granted includes the area embraced by the railing.

Each column within the building will be lettered and numbered, the letters designating the lines of columns, lengthwise, from east to west, and the numbers the lines, crosswise from north to south. Each exhibitor will have his location defined with reference to the nearest column,

and the official directory of the building will give the position according to this system.

Exhibitors having space granted in close proximity to the columns or outer wall of the building will be furnished from the Bureau of installation with drawings showing the form of the columns, the water spouts, and the available wall space. Cards stating the exhibitor's name, class of objects, catalogue number, place of manufacture, and price will be affixed to goods under such regulations as the commission may prescribe.

All products arriving at the doors of the building by rail, wagon, or otherwise, will be received by the Bureau of Transportation and delivered on the space granted.

All exhibits must be arranged, completely and finally in position, not later than May 1, 1875.

WHITTON'S STOP VALVE.

We publish herewith sectional views of two forms of a

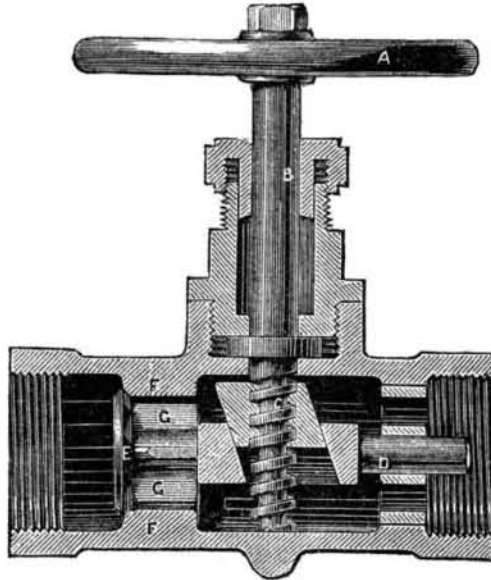

stop valve recently invented by Mr. Whitton, and introduced by Messrs. Low and Duff, of Dundee, Scotland. Its chief characteristic is its powerful closing and opening movement, obtained by a combination of the screw and the wedge. This gives it a ready control over the supply of steam or water under great pressure, and especially adapts it for use as a throttle for a locomotive or as a water hydrant valve.

In Fig. 1, the spindle, B, has a square thread, C, cut upon it, upon which slides a wedge block, moving in an inclined slot in the valve spindle, O, by which arrangement it will be readily understood that the disk, E, is powerfully controlled by the wedge, which is again acted upon equally and uniformly by the action of the screw. It will be seen that the stuffing box and gland, through which the spindle, B, passes, are both screwed into the socket of the valve. In Fig. 2, however, the stuffing box arrangement is improved, the box being driven in tight and screwed down, and the gland being

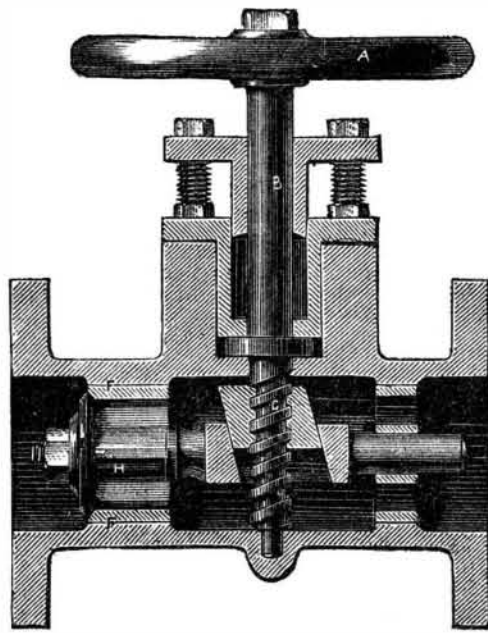

adjusted by studs. The seat of the valve, being put in separately, can be easily repaired. The bottom of the screwed spindle is also recessed into the bottom of the valve, giving lateral support to the spindle.

A New Textile Industry.

The government of India has been encouraging of late the culture of China grass (tschu-ma) or inner bark of the *Böhmia nivea*, which yields a very beautiful fiber, some three times as strong as hemp, and as soft as flax, while possessing a luster equal to that of silk. Although the properties of this fiber have long been known there has been an absence of proper machinery for its preparation, and until quite lately it has been supposed that only the green stem could be operated upon. Since it has been discovered that the dry stems may be treated by ordinary flax and hemp machinery, producing a fiber but little inferior to that obtained from the green plant, their utilization bids fair to constitute an important addition to existing textile industries.

Although the vegetable is indigenous to China, India, Japan, and has been successfully cultivated in Martinique, Ja-

maica, Trinidad, Algeria, Queensland, and Mauritius, and to a limited extent on some portions of our continent, we are not aware of any extended efforts being made towards its acclimatization in the United States. It is said that the plant adapts itself to climatic conditions with considerable facility, and hence it may be inferred that systematic culture in southern states would be attended with favorable results.

THE CATALEPTIC ROOSTER.

There is a curious experiment which any one who is the possessor of a rooster can try for himself with success, and which has never been positively explained. It is an ancient one, in fact it is two hundred years and over old, since it was commented upon by Kircher in 1646. Still it is none the less curious, and almost as much a subject of speculation now as it was when first observed. It is performed thus: Select a dark colored table with a smooth top; place it so that a narrow streak of sunlight will fall across the surface. The sunlight is not absolutely material to success, but we have found the desired result to be more quickly obtained when it is present. Then set the rooster on the table, and hold his head down so that his beak comes in contact with the wood. Now, with a piece of chalk and in the sunlight, draw a line straight from the bird's beak, as represented in our engraving. Move the chalk very slowly, and by the time the line is a couple of feet in length the rooster will fall into a cataleptic or trance-like condition; and although the hands are removed from his body, he will remain perfectly rigid for a minute or two. It is said that a black line on a white surface will produce the same effect. Hens may be similarly treated, but it takes much longer to get them into the trance state, it being necessary to hold the head down several minutes before they come under the influence.

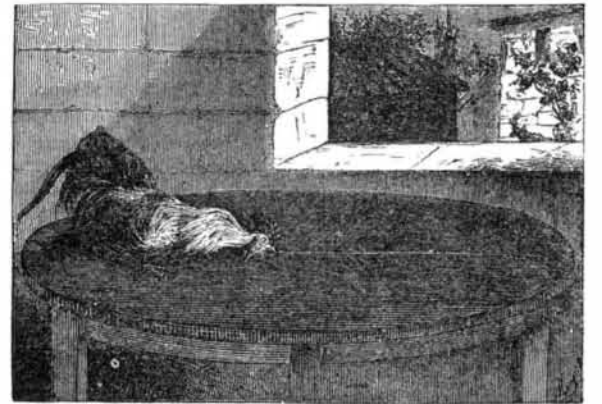

This phenomenon is termed hypnotism, or the result of a curious sleep-producing property incident to the fixation of the attention upon some bright object. It is by some considered a partial paralyzation of the brain. The same can be done upon human beings. The person should fix his eyes steadfastly on any glittering object, say a disk of silver paper, fastened on a black surface and brought within ten inches of his face, for about twenty or thirty minutes. A state of torpor supervenes, during which, if the limbs be gently raised, they will rigidly remain as placed. Surgical operations have been performed under these conditions without causing suffering to the patient.

A Method of Increasing the Solubility of Salicylic Acid.

The solubility of salicylic acid is enormously increased by the addition of borax to the water, so that as much as ten parts of the acid can be dissolved in 100 parts of water, if eight parts of borax be present. This discovery we owe to Dr. H. Bose, assistant in the Surgical Clinic at Berlin, who has contributed a paper of much interest to the *Berliner Klinische Wochenschrift* (No. 28, July 13), to which we are indebted for the following details. The solution should be made by first dissolving the borax with the aid of heat, and then gradually adding the salicylic acid to the boiling fluid. Since commercial samples of both these drugs are not chemically pure, a small amount separates, and requires to be filtered off on cooling. The filtrate is a clear yellowish or light brown fluid, according to its concentration. The proof that the addition of borax does not convert more than a part of the salicylic acid into salicylate of soda—a salt devoid of antiseptic properties—is easily shown; for if we dissolve 6.9 parts of the acid in 100 parts of boiling water, and then add 2.89 parts of bicarbonate of soda, the carbonic acid in the latter is set free, while the soda combines with the salicylic acid, and on cooling there is such an abundant deposition of the excessive acid that the whole liquid becomes nearly solid, owing to the formation of crystals. Now, if the whole be reheated until the acid is completely dissolved, and then 3.58 parts of boracic acid added, no deposit of any kind occurs on cooling. The most suitable strength in which the above solution can be used for direct application to wounds is, according to Dr. Bose's experience, one which contains from 2½ to 5 per cent of salicylic acid, and 2 to 4 per cent of borax. Solutions containing more than 5 per cent of acid are too irritating, and give rise to a very abundant capillary hemorrhage if applied to the surface of a fresh wound. Dr. Bose speaks highly of the result obtained with the boro-salicylic dressing in a number of cases of removal of small tumors. The operations were all performed without the spray, and only the sponges and forceps used were cleansed antiseptically with the above solution. The wound was thoroughly washed with the same liquid, and then a thick layer of salicylic wadding, also soaked with it, was laid on its apposed edges, so as to reach several finger's breadths beyond them