

IMPROVED POWER COUPLINGS.

At the recent meeting of the Iron and Steel Institute of Great Britain, a paper on power couplings for rolling mills and other machinery, the joint production of Messrs. F. H. Varley and Edward Furness, was read; and its chief point was a description of a new means of controlling and reversing mills which receive their power from a continuously and uniformly driven shaft, where the fly wheel picks up the accumulated momentum. This is accomplished by the means shown in our engravings, in which Fig. 1 shows the ordinary reversing gear, the shaft having an hydraulic coupling, the interior of which is shown in Fig. 2. The wheel, W, and the screw-shaped boss, S, is loose on the shaft, A; and the boss acts against a screw-faced cam, S', at the end of the ram working in an hydraulic cylinder, C, the packing, I I, being between the ram, shaft, and cylinder. The ram has lugs, G G, which move in slots which allow the ram to glide into the cylinder, but prevent the rotation of the ram. India rubber balls, F F, are placed in the water of the cylinder. Upon motion being communicated to the shaft, A, in either direction of the arrows, by the clutch, it causes the cylinder, C, and the ram, S', to revolve together and drive the wheel, W, by the screw-shaped faces acting against one another like the horns of a common fork clutch. Now, should there arise any sudden strain on the wheel, W, the shaft, A, and the attachments to it will not receive the shock, but will continue to rotate, and the screw-shaped face, S', of the ram, acting on the similarly screw-shaped boss, S, of the wheel, will force the ram into the cylinder, C, and compress the elastic material placed in the water, which will spread the force of the blow over a period of time and destroy its intensity; and when an equilibrium of power is established, the ram, S', will resume its original position by the screws gliding back over one another in proportion as the strain is reduced. It is preferred to make the pitch of the screws wide, so that the elastic material may be able to better overcome the resistance.

The action of the coupling may be briefly described thus: The screw-shaped faces, S and S', act against one another as a common fork clutch, and when the shaft, A, is in motion it carries round with it the cylinder, ram, and wheel; if the wheel be retarded the shaft will continue to rotate, but in so doing forces the ram into the cylinder until the elastic material is compressed with a force equal to the resistance opposing the rotation of the wheel; when the obstacle is passed, the pressure in the cylinder will be in excess of the work then doing, this accumulated pressure will be given out again and bring the wheel, W, which drives the mill, quickly to its original speed, and this is effected as gradually as the shock of the stoppage had been previously relieved by the form of the screw faces, S and S', so that there is neither concussion nor sudden strain in stopping or reversing.

Figs. 3 and 4 show forms of right and left-handed screws combined, which can be used for forcing the ram into the cylinder, supposing the shaft to be driven in either direction.

IMPROVED BARREL HOOP.

We illustrate herewith a strong and cheap hoop for fastening on kegs, pails, tubs, and other similar packages. The de-

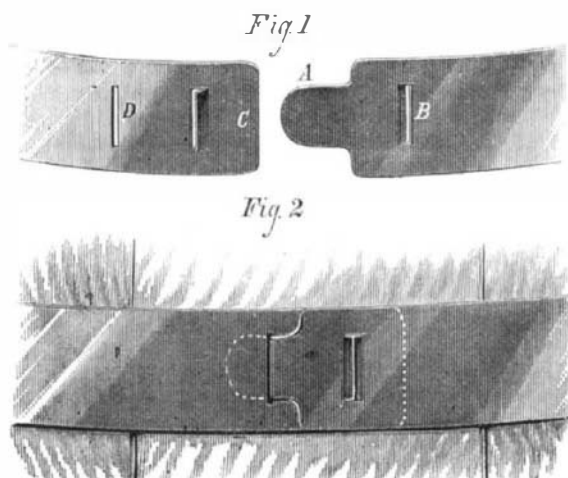

vice, which is both simple and ingenious, may be entirely made by machinery and placed in the cooper's hands complete in itself, no hammering being necessary to put it together for driving on the barrel. It requires no rivets; and hence the labor of making holes and of securing such fastenings is obviated, thus saving time and expense. Fig. 1 shows the manner in which the ends are formed, and Fig. 2

represents the extremities locked together. One end has a tongue, A, and a slot, B, the projecting piece caused by the cutting of said slot at three sides being bent to the rear. The opposite end has also a slot, C, similar to B, the piece being, however, turned to the front, and another opening, D, from the interior of which the metal is altogether removed. In locking the ends the tongue, A, enters the opening, D, as indicated by dotted lines in Fig. 2, and the projecting piece of

herewith illustrated is an attachment to the ordinary dish pan, into which the dishes are placed to drain as washed, the water dripping from them through the bottom of the receptacle and into the pan below.

The device consists of a crescent-shaped pan, A, which is supplied with suitable lugs by which it is attached on the edge of the dish pan, the bottom of which is perforated. As shown in the engraving, the articles are placed in this pan, where they drain quickly and thoroughly. The attachment may also be used as a colander for draining the water from vegetables. Three sizes of the invention are now constructed.

Patented December 15, 1874. For further information address the patentee, Mr. J. R. Abbe, Providence, R. I.

The Eagle Wing Propeller.

We recently witnessed a trial of Judge Patterson's new screw propeller the Eagle Wing, to which reference has lately been made in a letter of Mr. R. H. Buel, published in our advertising columns. The screw (of 12 feet diameter) was placed in the New York Herald steam yacht which vessel steamed about the harbor for some hours, in order that her speed might be tested

over measured distances. The best time made was a distance of two and a half miles in ten minutes. The propeller worked with remarkable smoothness, the after part of the boat being almost entirely free from the vibration ordinarily noticeable under like circumstances.

FULLER'S COMBINATION PACKING.

A new packing is represented in the annexed engraving, by the use of which fluted rods are prevented, and which may be employed on all kinds of steam engines, pumps, presses, etc. It is claimed to produce less friction on the rod or stem, and to be of much greater efficiency than any other packing now in the market.

It is composed of a coil of hemp rope, A, and a coil of rope, B, made of rubber cloth. The hemp is well filled with pulverized soapstone. Both ropes are wound around a mandrel of the size of the rod or shaft to be inclosed, and then surrounded by a casing, which consists of a rubber tube, C, enveloped in canvas or other flexible material, D. The piece is then cut off square so as to fill the stuffing box. The packing may be set in place by cutting it open longitudinally, either in parallel direction to its axis, or obliquely, as shown in the illustration.

The device is elastic, and is made to hug the shaft or rod by screwing down the gland. The rubber casing keeps the coils in place, and the soapstone combined with the hemp prevents friction. The inventor informs us that one set of packing has been used in freight and passenger locomotives for from four to six months, and in stationary engines for from eight to twelve

months, requiring tightening but once a month. The invention is simple and appears to be durable, while its friction-reducing qualities will probably render it, in large measure, a preventive of wear upon the moving mechanism.

Patented through the Scientific American Patent Agency,

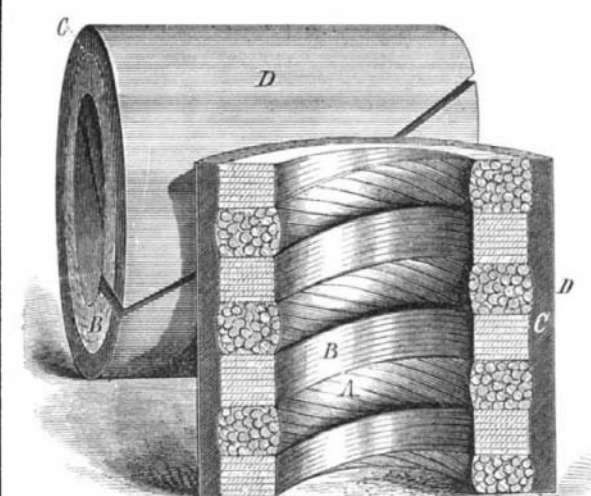

January 13, 1874. For further particulars address the inventor, Mr. C. H. Fuller, Akron, Ohio.

Twenty-four Hours at Sea in a Life Preserver.

Captain Boyton, whose daring exploits as an exhibitor of the new life-preserving dress we have heretofore mentioned, lately accomplished a greater feat than ever before, namely, the crossing of the English Channel. He started from Boulogne in France at 2.30 A. M., and paddled himself across the sea, 25 miles, to Folkestone, England, in 24 hours.

VARLEY AND FURNESS' POWER COUPLING.

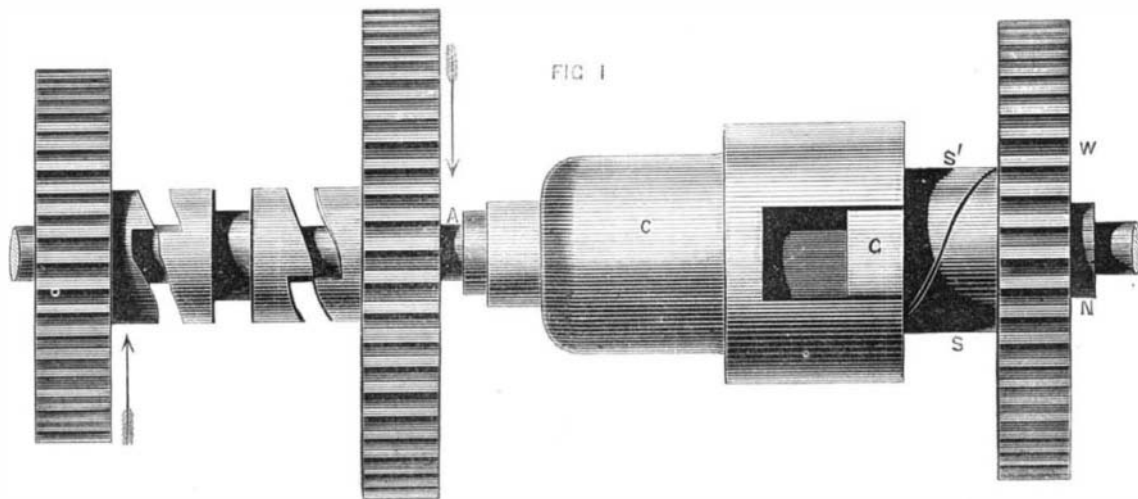

slot, B, enters slot, C, and vice versa. When the fastening is to be extra strong, for large packages, a series of two or more slots, like B C, can be made. This makes a firm, tight joint, with no ends exposed and liable to be turned back, the hoops being so broken in rolling the barrel.

The device is claimed to be stronger than the hoop fastenings now in use, because it presents a greater surface to the strain. It may also be adapted to serve as a bale tie, and in many other cases where a fastening of the ends of bands is necessary. If desired, the hoop can be removed from the

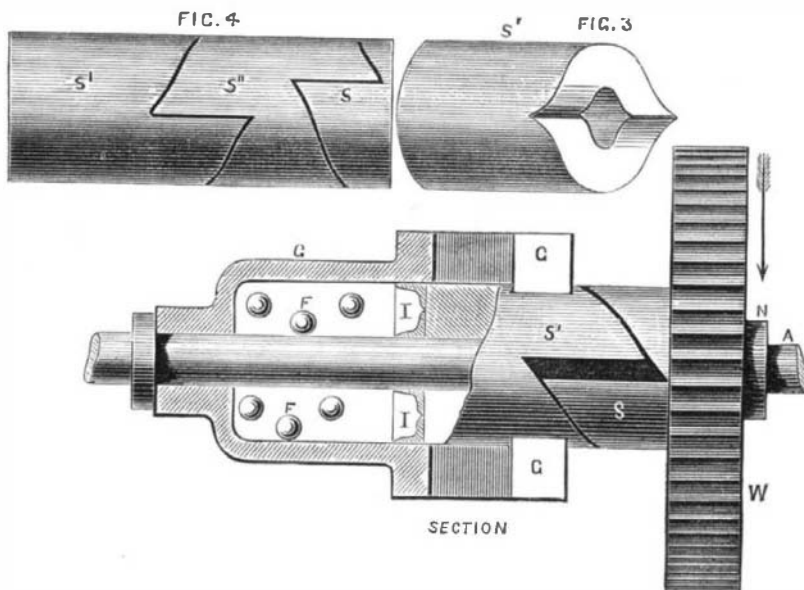

barrel and opened, when it is ready to be applied to another cask in as good condition as when first used.

Patented through the Scientific American Patent Agency, April 27, 1875. For further particulars address the inventor, Mr. Leopold Weil, 18 Market street, Chicago, Ill.

ABBE'S DISH AND VEGETABLE DRAINER.

Dishes, when laid aside to drain in a pan or sink, frequent-

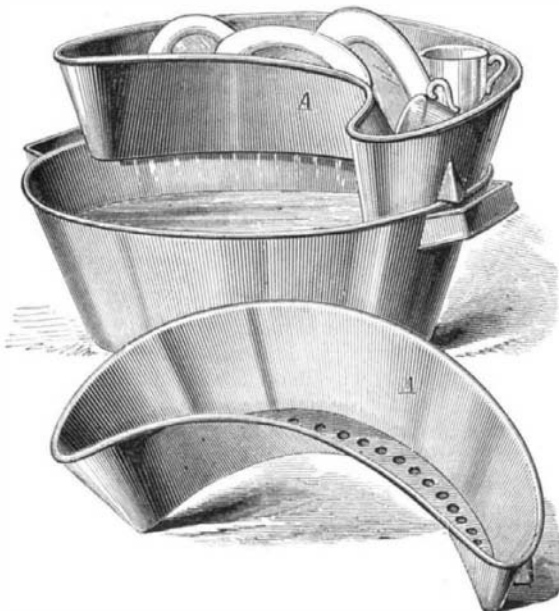

ly slide one upon the other, and become chipped and cracked; while occasionally, even when carefully piled, an accidental blow may result in the overthrow of the heap and consequent wholesale breakages or injury to the china. The invention