

THE AUTOMATIC COW MILKER.

A correspondent of ours, in making some researches in the Patent Office recently, stumbled across an old device among the forfeited applications, which appears to be an automatic cow milker. From sketches furnished us, we have prepared the annexed engravings, showing the invention as applied to the animal and, separately, in section.

About all that is necessary is to insert two tubes into the teats, through which the milk flows into a receptacle strapped under the udder. The vessel and the cow are to be permanent companions, for the present antique method of milking is no longer required. No longer will the horny palms of the aged agriculturist irritate the tender members of the patient brute, in vain endeavors to elicit milk which is not

Fig. 1

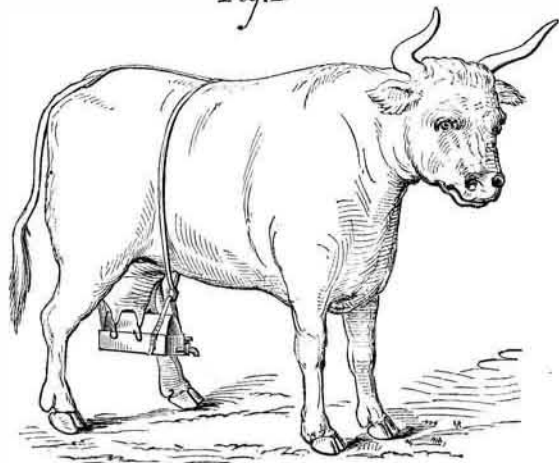

there; no longer will his mellifluous accents be heard requesting her in winning tones to "come down," nor will the atmosphere of the barnyard vibrate with his wild imprecations when injured female dignity stirs up the well filled bucket with her hoof. When milking time arrives, a pail receives, from the opened faucet, the contents of the vessel, which is thus drawn off as easily as water from a cooler.

An irresponsible person, connected with this office, suggests that cows, provided with this device, might be driven by milkmen to their customers' doors, and the milk removed as wanted; and further that, by setting a dog after the animal, she might be induced to get up sufficient motion to churn the milk into butter. We have called the attention of the health authorities to the dangerous ignorance of our employee; for should he ever embark in the milk business, his erroneous views might lead him to supply the lacteal fluid in an unchalked and undiluted state to his customers, and so to produce widespread disease. Any inventor, however, who will find a way of combining a neat water reservoir and pump with this apparatus, will doubtless find his invention

Fig. 2

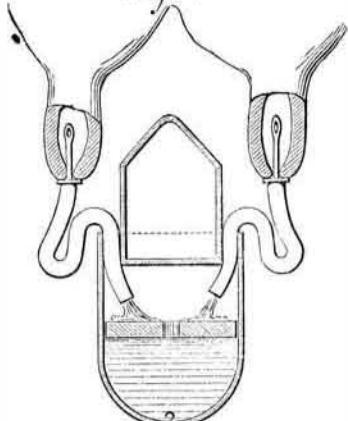

vastly appreciated by the average New York milkman. A little ingenuity, we think, could devise a kind of treadmill, to be worked by the cow, to operate a pump handle.

ENAMELED AND EMBOSSED PHOTOGRAPHS.

Take a piece of clear glass, free from bubbles or scratches, and clean it by immersing in a solution of concentrated potash over night. Wash thoroughly in clean water, and immerse for a few minutes in a mixture of nitric acid and water, one part of acid to three of water; let dry from the acid without washing. Now coat your plate with the following: Plain collodion one ounce, glycerin half a dram, and let dry. Then take sheet gelatin and soak it in cold water until it is soft; then put it in a cream pitcher or a wide-mouthed bottle, and cover with water. Dissolve the gelatin by heat, immerse your print in this warm gelatin, and lay it face downward on the collodionized plate, carefully pressing out all air bubbles; now cement with gelatin a piece of thin Bristol board, previously dampened to make it pliable, to the back of your print. Let dry thoroughly, and loosen the edges with a knife blade, by running around the glass between the print and the glass, when the whole thing will leave the glass with a very superior polish; it is now ready for pressing in Ormsby's cameo press, the simplest, most practical, and cheapest cameo press ever invented. Any carpenter will make one for about three dollars. The press and process are free

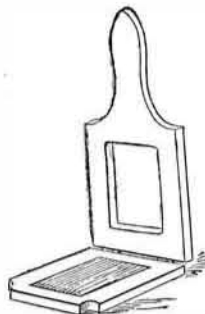

ward from the driving shaft to increase the throw of stroke of the plunger. When it is adjusted back in contact with the stop, the action goes on as before, so that the stop saves the time and labor which would be otherwise carelessly expended at every change of the adjustment of the wrist pin.

for the use of the fraternity. This process is superior to any. Where rubber is used in the collodion, they will never crack in the pressing; and where the rubber gives less polish than collodion alone, the addition of glycerin gives an extra polish. I enclose you a photograph of my press. It is made of maple wood, three quarter inch thick. The raised center for molding is glued on. The top and bottom are hinged together.—E. D. Ormsby, in Philadelphia Photographer.

WORSWICK'S IMPROVED PUMP MECHANISM.

We illustrate herewith an ingenious device for converting motion, arranged in connection with a pump. It seems to do away with countershafting and other connections, thus materially decreasing the cost of the machinery, while it renders the latter easier to set up. It is adapted to almost any position, and is entirely free from any complication in its working parts. As applied to a pump, as will readily be perceived from the following description, it insures a nice adjustment of the stroke, so that a regular supply of water can always be obtained. This is an advantage of importance, as it is scarcely necessary for us to point out that an irregular feed is alike fatal to uniform pressure of steam and economy of fuel.

Fig. 1

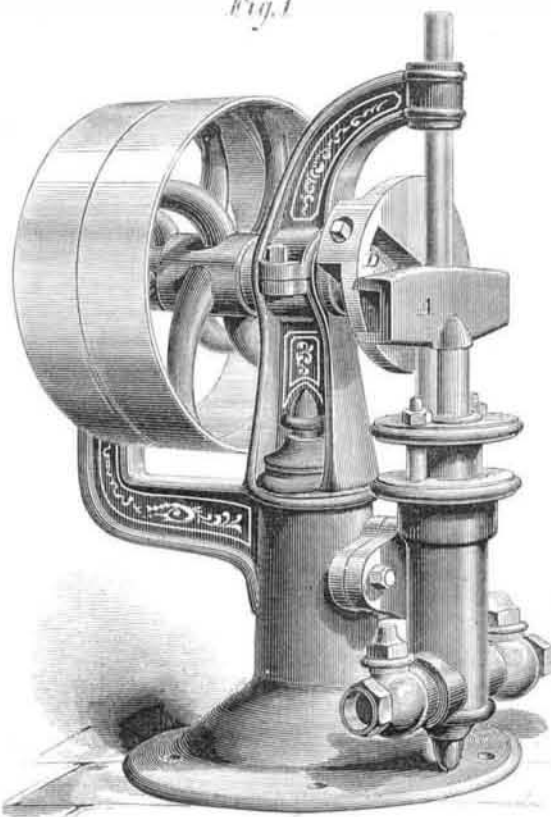

The entire machine is shown in perspective in Fig. 1; the sectional view, Fig. 2, will aid to obtaining a clear comprehension of the essential features of the mechanism. The pump plunger has a slotted cross arm or yoke, A, in the slot of which works the wrist pin, B. This, as the head, C (fixed axially on the driving shaft), revolves, causes a reciprocating movement of the plunger. The wrist pin is attached to a slide which is adjusted in the diametrical slot, in head, C, by means of a screw, D, passing through it, so that the distance between the wrist pin and shaft or axis may be increased or diminished at pleasure and the throw of the plunger correspondingly regulated. A stop, E, is provided for the pin, B, which is adjustable by a nut screwed on a stem, projecting through a slot in the wrist pin plate. The position of this stop piece indicates the adjustment of the pin, B, for running the pump. The pin may, however, be adjusted out-

Fig. 2

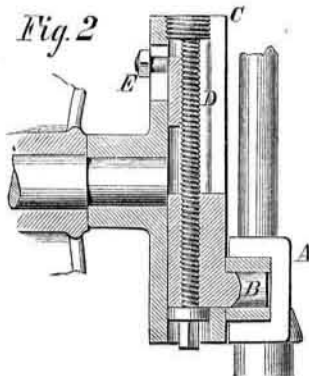

Patented through the Scientific American Patent Agency, June 9, 1874. For further particulars address the inventor, Mr. Thomas Worswick, Guelph, Ontario, Canada. Pumps thus fitted may be obtained of Messrs. W. L. Chase & Co., 95 and 97 Liberty street, New York city, or of the Armstrong Heater Manufacturing Company, Toledo, Ohio.

THE total number of complete patents issued in England, during the last year, was 2,906. In the United States, 12,864 patents were issued during the same period.

MULLER'S NON-EXPLOSIVE SELF-LIGHTER.

The annexed diagram represents an improved form of the Döbereiner or hydrogen lamp, a well known and useful apparatus in every chemical laboratory. The reservoir is filled with water acidulated with sulphuric acid, and a piece of zinc, inclosed in a bottomless tube, is lowered therein. The hydrogen thus generated rises through the tube, and, when the stopcock is pressed down, escapes from a small orifice above, and comes in contact with a fragment of spongy platinum held in the small bell shown. The platinum is thus caused to become highly heated and to ignite the gas jet. The improvements which this device offers over the ordinary lamp

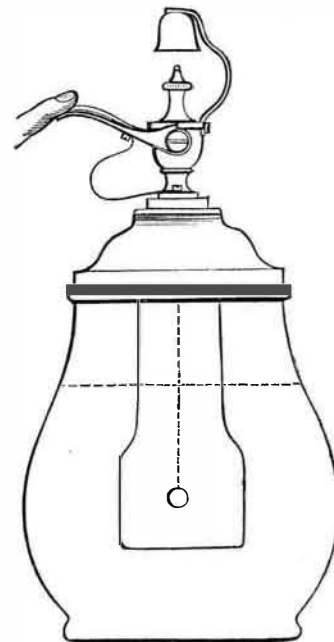

consist in the vertical channel through which the hydrogen passes. When, as is usually the case, the gas is forced to turn into a horizontal outlet, the small particles of sulphuric acid, which are carried up, accumulate in the passage, corroding the metal and preventing a free escape of the gas. By having the whole channel in a vertical position, the acid will readily flow back to its reservoir.

By securing the spongy platinum within a suspended bell it is covered and protected from injury. A working model of this invention can be seen at the office of the American School Apparatus Company, No. 21 John street, N. Y. For further particulars address the owner of the patent, Mr. Joseph Hertford, P. O. Box 998, New York city.

SHOEMAKERS' COMBINATION TOOL.

By means of the ingenious contrivance represented in our illustration, the shoemaker is enabled to draw the upper of his work into place, pierce a hole for the peg, and drive the latter home, all without once laying down the tool. This is accomplished as follows: The upper is grasped between the curved jaws of the pinchers, A, and pulled into position. The instrument is then reversed while being raised, and, by a blow, as if with a hammer, the awl portion, B, is driven into the leather. A peg, taken from the mouth, is inserted in the hole, and the tool once more reversed. Lastly, a stroke from the hammer, C, forces the peg into place.

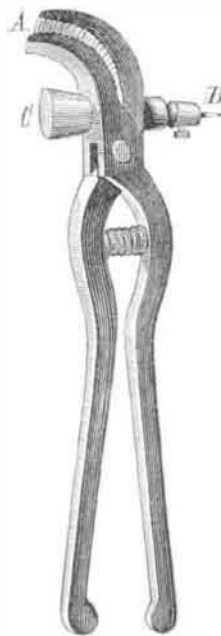

In this way the lasting of the shoe may be finished with considerable rapidity, and consequent economy of time and labor.

The device was recently patented through the Scientific American Patent Agency, by Mr. Joseph F. Ober, of Mount Desert, Maine.

Surgical Freezing.

The successful employment of an anæsthetic which prevents pain without destroying consciousness is a matter of interest and importance to medical people everywhere. Dr. B. W. Richardson, in the London *Lancet*, describes two operations of this kind, by him performed, for removal of cancerous tumors of the breast, both patients being ladies. A spray of common ether was directed upon the tumor until thoroughly chilled. The lighter fluid, a compound of ether with hydride of amyl, specific gravity 0.720, was then applied until the whole of the breast was frozen like a snowball. Instead of with a scalpel, the incisions and removal were effected by means of small, strong, sharp, and curved scissors. The use of this instrument is considered essential. The operations were successful, the healing speedy, without discharge or trouble of any kind.

AN EIGHTEEN INCH RAILWAY.—The narrow gage tramway, laid down along most of the avenues of the Royal Arsenal, Woolwich, has proved so completely successful that it has been decided to introduce the system at the new works at Chatham. The gage is only 18 inches.