

CONCRETE SIPHONS ON THE CANAL QUINTINO SELLA, LOMELLINA, ITALY.

The importance of concrete made water cement, as a substitute for brick or stone in the construction of hydraulic works, is now beginning to be more fully recognized by Italian engineers. A few notes on some important works of this class that have recently been carried out for the Canal Cavour Company on the extension of the branch canal Quintino Sella, will not fail to prove interesting to our readers. In consequence of the scarcity of bricks, and the short time (four months) that was allowed for the construction of this canal, the company determined to accept the proposal of Signor Giuseppe Frattini—who has successfully introduced the use of cement concrete into Italy for the construction of hydraulic works—to build all the siphons for the passage of existing irrigation channels under the new

The dials are ten feet in diameter, each hour being cut in relief from a single block of stone. The hour hands are four feet in length, and the minute hands about five feet four inches. The clock is forty feet above the dials, and the movements of the hands work through long tin tubes encased in oak. There are in the clock tower three large cylinders, carrying steel and brass cog wheels, the largest wheels being two feet six inches in diameter, and the smallest being seven inches. In all there are twenty seven wheels, not counting the friction rollers. The pendulum rod is made of wood, twenty-one feet in length, and having at the lower extremity about five feet swing. In this there is a trade secret. Wood shrinks sideways, while iron, steel, brass and other metals shrink in all directions. Therefore wood, well seasoned and waxed, is used for tower clock pendulums. Three weights are used, hung at the ends of

H. The latter then rotates in the direction of the arrow on the right of Fig. 2. To reverse the revolution, the cylinder is carried over to engage with the opposite wheel. The valve, E is consequently rotated in the contrary direction, compressing the air in the annular chamber, K, which slowly escapes by the small orifices, *i i*, in the wing, F, thereby filling the free space formed in rear of valve, E. The rotation of the cylinder continuing, the pressure on F augments and can be rendered as strong as desirable by regulating the size of the escape orifices; so that, in fact, the reverse motion of the cylinder may be gradually started by the confined cushion of air, before the valve comes in contact with the opposite side of the wing. The latter, with the valve, may of course be suitably packed so as to ensure the air escaping from no points except the apertures, *i i*.

This device, though open to objection, principally through

LONGITUDINAL SECTION OF SIPHON

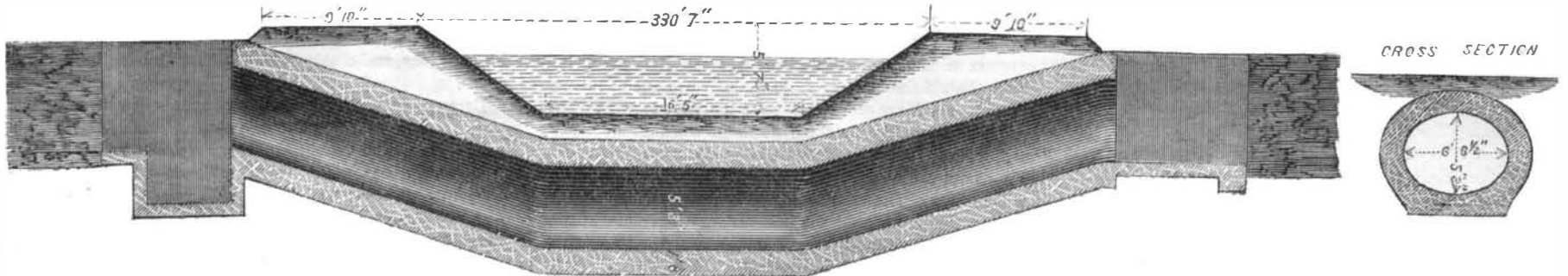

CONCRETE SIPHONS FOR CANALS.

canal in this material. This system of construction is exceedingly simple, requiring no skilled labor, and, when ballast can be had easily, is far cheaper than brickwork, and probably more durable. The cement used was that manufactured at Grenoble, and known as "ciment de la porte de France," the quick setting quality—*à prise prompte*—being mixed with the slower setting quality—*à prise lente*—or so-called Portland cement, manufactured at the same place. The mixture of the rapid setting quality with the Portland is for the purpose of making the work set quicker than it would otherwise do were only the latter used. The proportions in which the two qualities of cement are used should be regulated according as it is required to hasten the setting of the work, so as to be enabled to draw the core and carry forward the molds. It must be borne in mind, however, that the addition of the quick setting cement tends to weaken the cements, and should not be used in greater quantity than that absolutely necessary. The sand and cement are first mixed with water, the requisite proportion of gravel is then added, and the liquid concrete is poured round a wooden core supported by two molds placed about 6 feet apart, and of the exact section of the work to be executed. Laggings are placed round the external diameter of these molds, and the concrete is well rammed in the space thus formed between the outer casing and the core, this latter being drawn forward as the work proceeds. To facilitate the drawing forward of the core it should be made slightly tapered, and in order to obtain a truly cylindrical section in the concrete tube it should be covered with a plate of sheet zinc, which is kept in place by small wedges. On drawing the core these wedges fall out, and the sheet of zinc that remains behind can then be easily removed. The sand and ballast should be clean; and when easily obtained, the granite chips from a stone cutter's yard add considerably to the strength of the work. The tube being completed to the required length, wingwalls are then added of any required dimensions, and in this manner a monolithic mass of concrete is formed, which, a few hours after completion, when struck lightly with a hammer, rings like a bell. The siphons constructed by Signor Frattini on the Quintino Sella canal are fifteen in number, of which eleven were of a circular form, varying in diameter from 0.25m. (9.8 inches) to 1.00m. (39.1 inches), one double siphon, of which each tube is 0.80m. (26.24 inches) in diameter, and three of oval section, 2.00m. (6 feet 6 inches) in width by 1.60m. (5 feet 8 inches) in height (*vide illustration*), probably the largest works of this class that have ever been made. For building these siphons movable cores were not used, as the difficulty in drawing them forward would have been too great, and it was thought preferable to form the invert in the usual manner, building the arch afterwards on centering, which was struck as soon as finished, and set up again for building the next length. Signor Frattini is now in treaty for carrying out a colossal work of this nature, which will surpass in boldness anything that has hitherto been made in cement. This work will consist in a double siphon about 100 meters (330 feet) in length, each tube being of the same dimensions shown in illustration. This siphon is intended for carrying the water of a canal derived from the river Sesia under a tributary torrent for supplying motive power to a large paper mill near the village of Serravalle, Val Sesia.—*The Engineer*.

The Clock of Trinity Church.

One of the largest and best tower clocks in this country is that of Trinity Church, Broadway, New York. It was made in 1846 by James Rogers, and is a splendid specimen of horological workmanship.

heavy, seasoned ropes. The largest is on the hour hand, and weighs 125 pounds. Bales of cotton are on the lower floor of the clock tower, so that if the ropes break the weights shall not fall into the body of the church. By a simple trip leverage, three bells in the chime are connected with the clock, and thus ring out the quarter hours, repeating on the last two quarters. Another lever tolls the hours. The clock is wound up once a week, taking two hours each time to raise the heavy weight from the cotton bale to the top of the works. To economize labor, a patent winch is used to perform this work.

REVERSING GEAR FOR ROLLING MILLS.

In order to effect the reversal of the motion of the cylinders of rolling mills easily and without shock, M. O. Reichenbach has recently devised the invention herewith illustra-

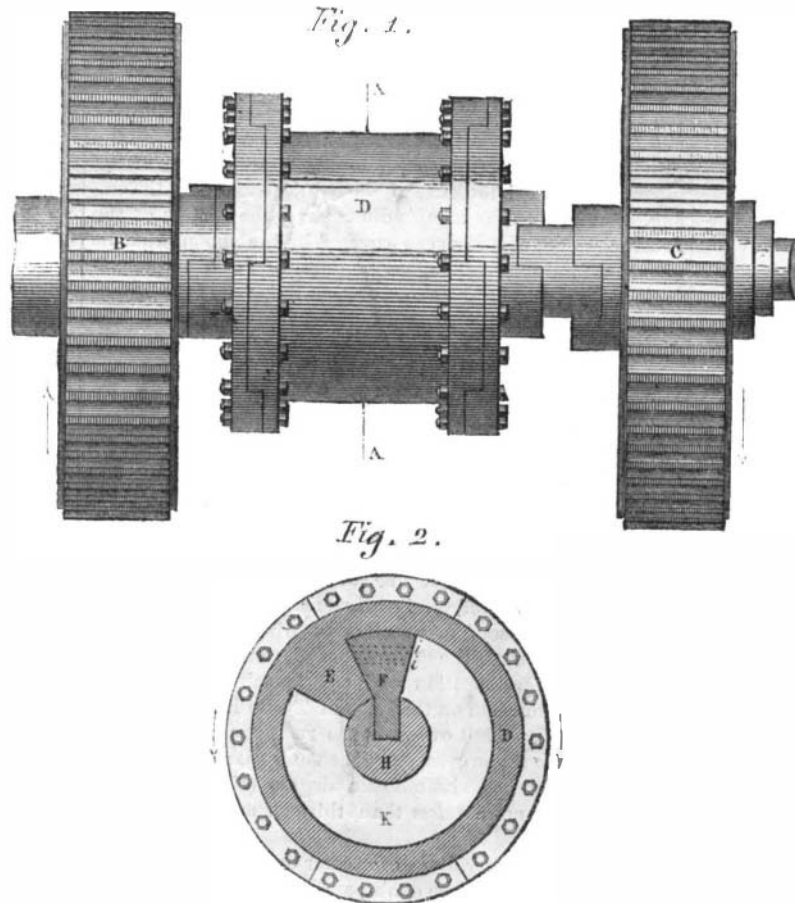

REVERSING GEAR FOR ROLLING MILLS.

ted, the engravings and description of which we extract from the Belgian *Bulletin du Musée*:

B and C, Fig. 1, are gear wheels which move freely in opposite directions upon the arbor, H. The cylinder, D, carries clutch couplings, which, as shown in Fig. 1, may engage with either wheel; for which purpose, the cylinder is capable of longitudinal motion along the arbor, H, around which it also revolves. E, in Fig. 2 (a sectional view through the line, A A), is a lug secured to or formed upon the inner surface of the cylinder, and fitting closely against the periphery of the arbor. The latter carries a steel wing, F, which bears against the interior of the cylinder and slides longitudinally in a mortise cut in the arbor, so as to follow the movement of the cylinder when the latter is transported, in either direction, to engage with one or the other wheel.

On power being applied, the motion of the toothed wheel is imparted to the cylinder, and from the latter (through the medium of valve, E, acting against the wing, F,) to the arbor

the weakening of the arbor by the mortise, seems nevertheless of considerable merit, and serves to exemplify an idea doubtless susceptible of extended application.

Hydraulic Fireworks.

At the Peterhoff Palaces, Russia, they have spray wheels mounted on posts, after the manner of the firework wheels. The spray wheels are driven by water pressure, and on turning they throw out beautiful streamers of water, which, when illuminated by sun light, or at night by colored lamps, present a most beautiful appearance.

Water pipes are also conducted through the branches of artificial trees, and splendid effects produced by the discharge of water in fine jets from the many branches.

A New Blue.

When phenol is treated with chlorine water, no reaction is observed, and ammonia added to the mixture subsequently develops no coloration. It is known that aniline, on the contrary, suspended in water, with the addition of a solution of chlorine, takes a rose color, which rapidly becomes purple, violet, and, lastly, brownish red, and that ammonia added at this last juncture increases the brownness. It is no longer the same when a mixture of a drop of phenol and a drop of aniline is submitted to the action of solution of chlorine. A permanent rose red is obtained, which may be turned to a blue either by ammonia or by the alkalis or alkaline carbonates. Acids restore the original redness. The author concludes that there exists a phenate of phenylamin; that the new body produced in the above reaction is a red acid, forming blue salts; the erythrophenate of soda may be produced by causing hypochlorite of soda to act upon the mixture of phenol and aniline. The blue thus formed is remarkable for its purity and extraordinary tinctorial power. If two drops of the mixture of phenol and aniline be added to two liters of water, and then treated with hypochlorite, the blue in an hour or two becomes so intense that it could be recognized even in 4 liters of water. This reaction may be useful in toxicological researches either for aniline or phenol. The purity and permanence of the blue might render it fit for the uses of the dyer, but it will not bear steaming. The extreme facility with which it is reddened by the feeblest acids is likewise an objection. In this respect it far exceeds litmus.—*E. Jacquemin*.

Artificial Ivory

Two pounds of pure india rubber are dissolved in thirty-two pounds of chloroform and the solution saturated with purified ammoniacal gas. The chloroform is then evaporated or distilled off at a temperature of 185° Fahr. The residue is mixed with pulverized phosphate of lime or carbonate of zinc, pressed into molds and cooled. When the phosphate of lime is used, the resulting compound partakes in a great degree of the nature and composition of genuine ivory, for we have the requisite proportion of the phosphate, and the india rubber, which takes the place of the cartilage; and the other component parts of the genuine article are of little importance.

THE railway tunnel of the West Side Railway, Hudson River, is now being pushed under the grounds of the United States Military Academy, West Point, N. Y. About 250 feet of tunnel have so far been cut.

THE *Railroad Gazette* estimates that the extent of new railways built in this country in 1873 will be more than forty per cent less than for 1872.