

SCIENTIFIC AMERICAN

A WEEKLY JOURNAL OF PRACTICAL INFORMATION, ART, SCIENCE, MECHANICS, CHEMISTRY, AND MANUFACTURES.

Vol. XXIX.--No. 9.]
[NEW SERIES.]

NEW YORK, AUGUST 30, 1873.

[\$3 per Annum.
IN ADVANCE

THE PULSOMETER.

A steam pump with no cylinder, no piston, no piston rod, no stuffing boxes, glands, cams, or eccentrics, no slide valves, cranks, or fly wheels, and consequently requiring none of the repairs or renewals incident to the above mechanism, is the negative definition of the invention, the distinctive name of which heads the present article. Positively speak-

Fig. 2

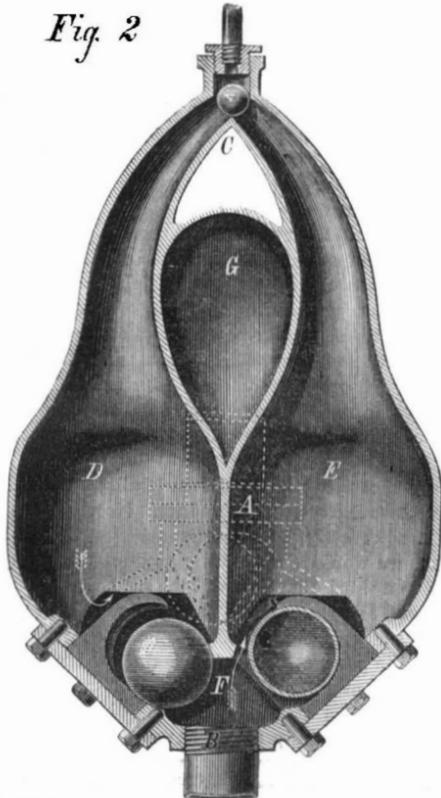

ing, the invention is a device in which steam and water are brought in direct contact in suitably arranged chambers, where, by the alternate vacuum and pressure of the former, the fluid is first lifted and then forced out, in other words, moved by direct acting pulsation: a utilization, in fact, of the simplest principles of hydro-dynamics by means of one of the simplest forms of machine.

From the sectional view, Fig. 2, the interior arrangement of the apparatus will be easily understood. Two long necked chambers, D and E, are joined together at their upper extremities, forming a common passage into which a metal ball, C, is fitted so as to oscillate freely between seats formed at the junction, thereby closing the orifice of either chamber, toward which it may fall. Steam enters from above, and hence the position of the ball, C, governs its entrance into one or the other vessel. Water, on the other hand, comes into the apparatus by the pipe, B, from below to the induction passage, F, which connects the lower portion of the two receptacles through circular orifices. In the latter, two spherical shells are arranged and seated so as to act as induction valves to the chambers respectively.

A is the delivery passage (shown in dotted lines), common to both chambers, and is also provided with a spherical shell, oscillating from side to side between seatings formed in the entrance to the conduits leading

into the two chambers, which acts as a delivery valve to each alternately. G is a vacuum chamber, connected with the induction passage through a downward extension (not shown) on the side opposite the delivery opening, A. Suitable flanges and covers are arranged at the bottom of the chambers to allow of the removal of the shell valves when necessary.

This entire apparatus, with all its chambers and passages, is cast in one piece, and at the same time with the induction shell valves in their proper positions, thereby forming their respective seatings, while chills of suitable form are placed so as to mold the seating of the steam and discharge valves also. Stud bolts are similarly cast in their proper positions upon all the flanged passages, ready for the screwing on of the flanges. As soon, therefore, as the core sand is removed, the flanges bolted on, and the steam and discharge valves put in their places, the pump, after the necessary connections are made, is ready for immediate operation.

Such is the simple arrangement of mechanical details, the working of which is equally uncomplicated. Referring again to Fig. 2, it will be observed that the ball, C, is on its right hand seat. Consequently steam has free entrance to chamber, D, the latter, with the suction pipes and other chambers, being supposed to be filled with water. The fluid in the left hand receptacle is therefore subjected to a pressure directly from above and the steam is thus applied in a manner to secure the least amount of condensation. The result is that the water line is gradually depressed, and the liquid forced out past the ball in the lower part of the chamber, which naturally takes the position indicated in the engraving, and thence out through the discharge opening, the shell in the latter yielding to the pressure and falling toward the right. It will be noticed that the shape of the chamber allows the steam to expand gradually as the fluid surface is depressed, so that the water is not agitated until the discharging outlet is reached. At precisely that moment agitation commences, the steam mingles and condenses, and, as the inventor expresses it, if a vacuum gage were applied to the chamber, "the needle would fly round from 0 to 28 like a streak of lightning."

The result of this sudden collapse is evident; the ball, C, is instantly drawn over to close the opposite orifice, the shell on the delivery conduit falls also back to the left, preventing the reflux of the water, and the induction valve ball is forced back against its guard, leaving a clear port for the column of water in B. To cushion the ramming action of the fluid thus drawn violently in, the vacuum chamber, G, comes in play. This, as before remarked, is connected with the induction chamber, F, and contains air in its upper por-

tion. A small air check valve is screwed into this vacuum chamber, which lifts, when a partial vacuum is produced therein, allowing the entrance of a small quantity of air, but closing against its return. The valve opens at each pulsation and its lift, and thus the amount of air permitted to enter, may be regulated by a suitable screw.

The operation described as going on in chamber, D, is in-

Fig. 3

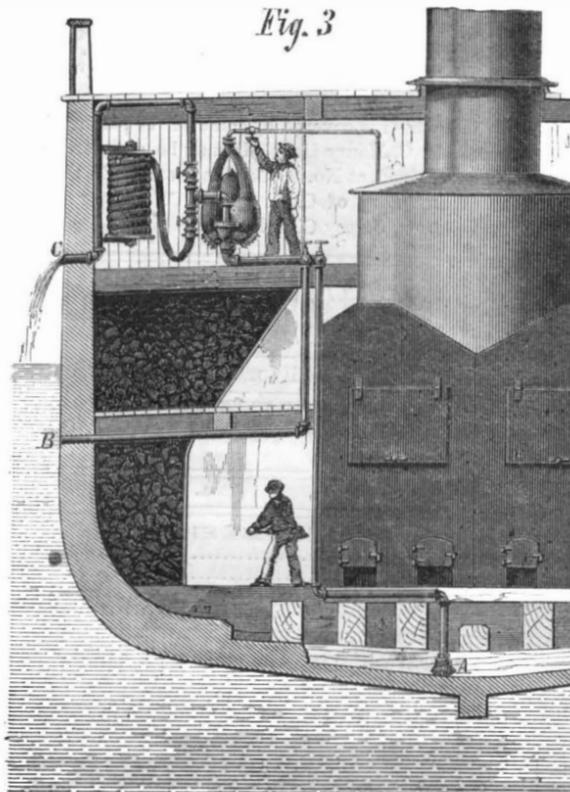

stantly repeated in chamber, E, the moment the ball, C, flies over. Consequently the receptacles filling and emptying alternately give, it is stated, all the elements of a double acting pump, drawing and forcing a constant stream at the same time.

Sufficient of the working of the apparatus has, we think, now been described to insure clear comprehension of the general operation. The functions of the various moving parts in detail, the reader interested can readily determine

for himself. It remains, therefore, to note the advantages claimed and the various uses to which the pump may be profitably applied.

Our larger engraving (Fig. 1) represents the pulsometer as arranged in a mine. In such localities, as many are aware, the pump is very liable to get out of order, work irregularly, and, in fact, form a troublesome part of mining economy. The present device, according to the inventor, is free from the difficulties inherent to ordinary apparatus. We are told that it works constantly as long as supplied with steam, requires no attention, shows no perceptible wear of parts, and does not become choked by sand, wood, or mud. The patentee also states that he has successfully applied the pump at a distance of 800 feet from the water to be raised, where 150 feet was clear lift. He adds that economy of

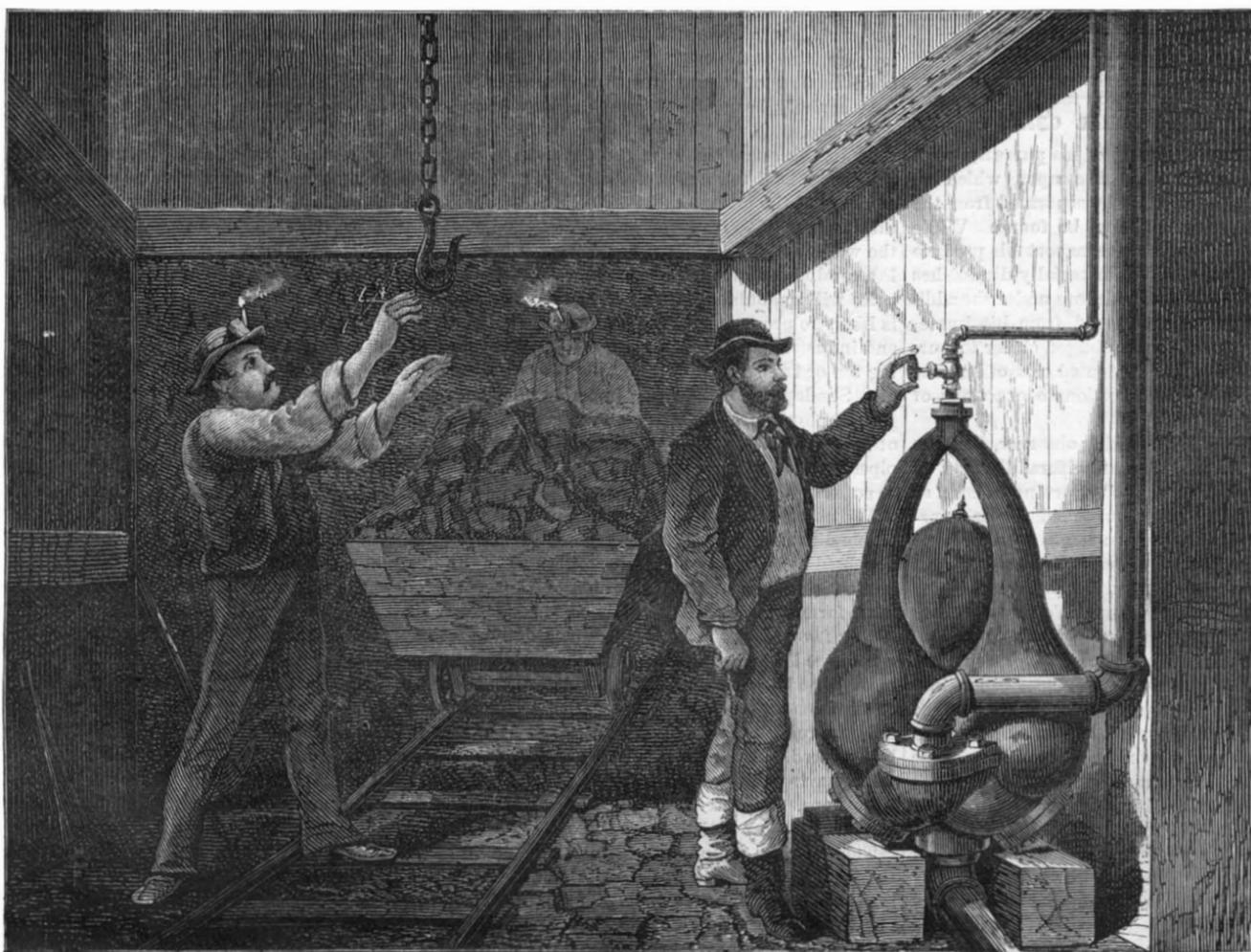

HALL'S PULSOMETER OR STEAM PUMP.—Fig. 1.

steam is one of the principal advantages of the invention, in addition to the saving effected in repair and care.

In Fig. 3, our artist has depicted the application of the pulsometer on shipboard, showing a double arrangement whereby it may be used for freeing the ship from bilge, or for drawing sea water, in case of fire or to wash decks. A shows the bottom of the suction pipe near the keelson, fitted with a suitable rose nozzle. This, provided with proper valves, connects with the pump and thence overboard at C. At B water is drawn in through suitable adjustment of the valves and carried to the coil of hose represented. The arrangement is simple and, doubtless, very convenient and effective.

Another application is to the locomotive: the small space required by the machine rendering it easily located and thus convenient for filling the tender from roadside streams, in cases of necessity. In addition to these instances, the pulsometer, it is claimed, may be employed for pumping deep wells, being suspended by a chain or rope, and lowered as the work progresses; for removing water from foundations, as we are informed that it will raise fluid containing fifty per cent of sand or mud; as a working meter, as, by knowing the exact capacity of the working chamber and counting the pulsations, the quantity of liquid moved at any time may be determined; and in fine, through its absence of complicated parts, freedom from requirements of oiling, packing, and constant supervision, for a multiplicity of other uses which circumstances will suggest.

The device, which is covered by some thirty patents, is the invention of Mr. C. Henry Hall. It may be seen, and other information obtained, at No. 20 Cortlandt street, in this city, or at the manufactory of C. H. Hall & Co., corner Hudson and Sussex streets, Jersey City, N. J.

Scientific American.

MUNN & CO., Editors and Proprietors.

PUBLISHED WEEKLY AT NO. 37 PARK ROW, NEW YORK.

O. D. MUNN.

A. E. BEACH.

TERMS.

One copy, one year.....	\$3 00
One copy, six months.....	1 50
CLUB RATES { Ten copies, one year, each \$2 50.....	25 00
{ Over ten copies, same rate, each.....	2 50

VOL. XXIX., No. 9 . . [NEW SERIES.] Twenty-eighth Year.

NEW YORK, SATURDAY, AUGUST 30, 1873.

Contents :

(Illustrated articles are marked with an asterisk.)

American asphaltum.....	137	Locomotive, articulated*.....	135
Answers to correspondents.....	138	Log house of Norway, the.....	136
Blue, a new.....	130	Mathematics, the study of.....	137
Brick compressing machine*.....	134	Meteor shower of August 10, the.....	132
Business and personal.....	136	Nature and art.....	131
Campbell.....	138	Notes and queries.....	138
Clock of Trinity church, New York city.....	130	Oil for gas, mineral.....	135
Concrete siphons on the Italian canals*.....	130	Oil wells of Pennsylvania, the flow- ing.....	128
Cotton chopper and cultivator*.....	134	Paint for canvas, waterproof.....	137
Crawfish, fresh water*.....	131	Patent right question, the.....	132
Devil fish, the.....	131	Patents, official list of.....	140
Dining table, Russian.....	134	Patents, recent American and for- eign.....	137
Engines of Admiral Porter's tor- pedo boat*.....	129	Phosphor-bronze, gear wheels of.....	136
Fibrin as a diet, artificial.....	133	Pulsometer or steam pump, the*.....	137
Fireworks, hydraulic.....	131	Reversing gear for rolling mills*.....	130
"For Inventors and mechanics".....	132	Sailing faster than the wind.....	132
Granges and their object, the.....	128	Scientific and practical informa- tion.....	129
Hartford Steam Boiler Inspection and Insurance Company, the.....	136	Sole sewing machine.....	136
Horticultural fertilizer, Jeannel's.....	133	Sun's distance and how it is meas- ured, the.....	132
Ice cutting ferry boat, an.....	136	Telescope, the million dollar.....	132
Inventions patented in England by Americans.....	137	Ventilators, car.....	132
Ivory, artificial.....	130	Vienna exposition, the—Letter from Professor Thurston.....	138

THE "GRANGES" AND THEIR OBJECT.

The agriculturist is, from the nature of his pursuit, necessarily isolated; and the greater the scale upon which his operations are conducted, the wider is he separated from the communities in which his market must be found. While thus compelled not only to raise but transport his produce to the consumer, at an expense which materially diminishes his profits, he, on the other hand, also labors under the additional disadvantage of being far removed from his immediate sources of supply; hence he is obliged either to purchase his necessaries of life at an augmented cost of importation, or else submit to the often extortionate exactions of agents and middle men.

It was a fact, evident to every thinking observer, that the state of affairs which existed in the agricultural districts of the west during last fall, resulting in the burning of corn as fuel rather than pay the high rates demanded for its transportation to eastern markets, was such as to necessitate speedy means of relief; while it led many to the thought that, if reform could not be effected through individual effort, it might be gained by aggregation. To these causes may be attributed the very rapid spread of an organization, the object of which is—setting aside all political construction, which is beyond our province—to bring the farmer into direct relations with the manufacturer and capitalist; and at the same time, by the agency of association, to improve his intellectual and social, as well as financial, condition. The system of granges, as they are termed, originated in 1867; but on being broached to farmers, it was regarded at the time with suspicion and virtually discountenanced. Up to the beginning of 1871, but 125 societies had been formed; but from the autumn of 1872, the plan has grown in popularity to such an extent that there are now over five thousand granges, aggregating 300,000 members; while it is estimated that fully 8,000 will have been organized before the close of the present year. The order of so-called Patrons of Hus-

bandry is modeled something on the Masonic principle, so far as secrecy and the observance of a ritual is concerned, the object of ceremonial restriction being principally, however, to excite an interest and engender a more fraternal feeling among individuals. The National Grange in Washington grants dispensations to form other lodges, and the masters of the latter, when a certain number are organized in a State, constitute a State Grange. The last body elects its own master, who is a member of the National Grange or governing authority. Both sexes are eligible to membership, and a certain amount of internal discipline is maintained.

These societies deal directly with producers, buying their supplies in quantities and paying cash. Contracts are made by agents with manufacturers to furnish various articles at the lowest price attainable. A list of parties thus agreeing is sent to every grange. If a farmer requires, for example, a reaper, a sewing machine, or a piano, instead of buying it from a middleman, he notifies the master of his grange, to whom he pays a stipulated price. An order from the official to the maker procures the desired article, and the same process is gone through with for anything else that a member may need. Necessarily, manufacturers are willing to sell to the granges; and in some cases, we learn, are satisfied to do an exclusive business with them. On their part, they save agents' commissions and send their wares direct from factory to depot for a certain cash profit. There are no vexatious delays, time sales, nor bad debts to distribute, perhaps, among the bills of other customers.

The cost of buying being lessened, the organization has yet to reduce that of selling. At present, and indeed for some period past, the attitude of many of the Western railway corporations and the farmers has been open hostility. The former refuse to reduce their freight charges, and the latter, except where compelled by circumstances, decline to pay them. Of course, politics are brought in, which add to the asperity of the war. The farmers point to the goods of the manufacturer traveling from terminus to terminus at charges far below those demanded for the transportation of the crops, and ask an equalization of expense, decrying the carrying of the wares of one man at rates less than that required for the produce of another. The railroads, on the contrary, assert that it is cheaper for them to transport goods in unbroken bulk from one end of their main lines to the other, shipping and unloading at points where facilities exist for the purpose, than to gather single individual crops from sparsely scattered intermediate stations.

Although no particular compromise has been suggested, the policy of the granges is toward negotiation and diplomacy rather than a continuation of the difficulty, toward securing as advantageous terms as possible from opposing capital rather than undergoing the losses of open rupture. The system, so far as its fundamental principles are concerned, is of material benefit to the farmer; but how far it will stand the test to which time will subject it, it is hardly possible to predict. It is not coöperation, nor are its supplies derived from establishments in the nature of coöperative stores. Briefly summed up, its object is to break away the barriers encompassing the farmer, which are the natural consequence of his isolation, and to bring him at least to a level, so far as the advantages of trade and social intercourse are concerned, with men of other callings.

THE FLOWING OIL WELLS OF PENNSYLVANIA— GREAT DECLINE IN THE PRICE OF OIL.

Within the past few weeks, a new section of the Pennsylvania oil region has been tapped by enterprising well drillers, and their labors have been rewarded by the opening of flowing fountains of the unctuous commodity. So prodigious has been the flow of oil that the proprietors, so it is reported, have scarcely been able to provide barrels and tanks fast enough to catch the liquid as it spurts from the pipes, and considerable quantities have run to waste.

The result of these new petroleum supplies is the overstocking of the market and the decline in price to the insignificant sum of 75 cents per barrel, delivered on the cars near the wells. At this figure the oil is almost given away. This is a condition that, probably, cannot long continue, and the price will undoubtedly soon rise again. But the depression is likely to prove very disastrous to large numbers of honest and industrious oil pumpers, who, from their wells furnishing ten or twenty barrels of oil per day (working night and day, Sundays included), were just able to make a living, and give employment to their hardworking assistants. Hundreds of these oil dealers will, we fear, be made bankrupt, their pipes and engines sold for old iron, and their families brought to suffering.

The new flowing wells are in Butler county, Pa., a considerable distance south of Oil City. The new oil region is supposed to be quite extensive. The opening of every new section is the signal for the formation of a new city. The Starr farm, near Grease City, is at this moment the most highly favored by the caprices of petroleum fortune. One well, here located, has been flowing over a thousand barrels of oil per diem for more than a fortnight, and several others in the immediate vicinity are regularly delivering five and six hundred barrels daily. Large numbers of new wells are being bored. Already a new town is in existence on this farm, having its hotels, boarding houses, livery stables and rum shops. Seventeen of the latter were in full blast within ten days after the oil began to flow.

The principal use of petroleum at the present time is in the form of illuminating oil. Various attempts have been made to employ it as a substitute for bituminous coal in the manufacture of illuminating gas; and if this could be accomplished with economic advantage, the demand for crude petroleum would soon be equal to the supply, and steady,

remunerative prices might always be expected. Some of the difficulties connected with the conversion of petroleum into illuminating gas are suggested on another page. The subject is well worthy of study, and we hope that some one will be able to solve the problem.

The discovery of new uses to which this abundant article can be put likewise presents itself as an excellent subject for research.

The employment of petroleum as a fuel, in lieu of coal, especially for use on steam vessels, has been repeatedly attempted, but without economical success. Weight for weight, petroleum yields fifty per cent more heat than coal. In markets where coal is worth \$6 a tun, petroleum must be supplied at 3½ cents a gallon or \$1 a barrel in order to compete, as a fuel, with coal.

THE STUDY OF MATHEMATICS.

We have frequently advised our readers who are deficient in a mathematical education to devote some time to the study of this science. It is scarcely necessary for us to advance any arguments in support of this advice. The statement that "knowledge is power" is always true, with certain limitations, and especially true with regard to the power which it puts into the mechanic's hands.

We have seen men who, in spite of strong efforts, had labored in vain from a lack of favoring circumstances. Not knowing how to study, and having no one to show them, all their time has been thrown away. Nothing can be equal in value to the efforts of a good teacher, in smoothing the path of the pupil; but perhaps a few general hints on how to study may do some good.

We suppose that our reader is thoroughly acquainted with arithmetic or the science of numbers, and that he is ready to commence the study of algebra, which may be called the generalization of arithmetic, operations being performed on general quantities, producing results that are general in their nature. If the student will fairly master this idea at the outset, it will be of great value to him in his future studies. Many a young man has gone entirely through a treatise on algebra without really understanding the purpose of his pursuit.

We say that the product of 4 multiplied by 6 is 24. Here we have two factors and a product. Now let us see if we can form a perfectly general expression of this nature. In this case, we would say that the product of two quantities is equal to a third quantity, and the next thing to do will be to represent this statement by an algebraic expression. To do this, let us represent the first quantity by *a*, the second by *b*, and the product by *c*. Then the algebraic expression of the statement given above will be *a* × *b* = *c*, and the statement is called the translation of the algebraic expression. Simple as this may appear, we have seen many students who professed to be well acquainted with algebra, who were unable to translate the most elementary expressions. The reader will doubtless see at once the value of this kind of practice. Since algebra is a process of generalization, or, in other words, since the results obtained are perfectly general in their nature, it is necessary to be able to translate these expressions and interpret the results. How unmeaning an algebraic expression appears to those who are not familiar with the subject! But, on the contrary, how much is conveyed by a few symbols to those who hold the key to the translation! Let the young student, then, make himself expert in the translation of algebraic expressions at the commencement of his course of study.

A teacher of great experience once told us that a very common answer to his question to a student: "Why is this so?" is: "The book says so, in such a place." An answer of this kind shows an utter want of appreciation of the nature of the study. Algebra is eminently a rational science, and the reason why can be given for any one of its propositions. The student should exercise himself in finding out the reason why, in any particular case, and should receive no statement in the book on trust. To say that there is such a rule without being able to give the reason for the rule is evidence of learning merely by rote, a method applicable to some branches of study but wholly out of place in this pursuit. A rule is merely the translation of a general formula, which formula has been established by exact reasoning. All the arguments must rest on some basis; so the principles of mathematical science are based on a few simple propositions, or axioms, which cannot be demonstrated and can scarcely be denied. These axioms being admitted, various propositions are established, the axioms being used as a starting point. The student can then have a sure test, as to the truth or falsity of any statement made by the book, by tracing it back to its original source.

We frequently receive questions from correspondents who ask for rules that can be worked out by arithmetic, as they do not understand algebra. Frequently, as no data are sent, the question could not be answered without the use of algebra. But as the correspondent does not understand how to use a formula, the translation is sent, and he has only to apply the data. So, after all, we are using an algebraic formula in answering his question, merely putting it into a shape in which he can use it. This is quite sufficient to show the general nature of the science. We feel convinced, from the many communications we have received on the subject of a mathematical education, that our present remarks are timely, and we shall be amply repaid if they prove of any assistance to the young student. We do not mean for him to rest satisfied when he has finished the study of algebra; but our hints on this subject will apply with equal force to any other branch of mathematics.

It does not matter so much what text book the student uses as how he uses it; and as most mathematical works are

written with the expectation that they will be interpreted by teachers, our remarks may not come amiss to those who are obliged to study without assistance from an instructor.

We shall be happy at all times to aid the young student in his difficulties, and hope that those who are in need of assistance will apply to us freely. We shall, from time to time, give the solution of simple problems, illustrating the value and use of a right understanding of mathematics and mechanical principles.

ENGINES OF ADMIRAL PORTER'S TORPEDO BOAT.

In a recent number of the SCIENTIFIC AMERICAN, we gave an illustration of this vessel, and we now present a sketch, showing the general arrangement of the engines, which are quite novel in design. The engines are of the compound variety, with four cylinders, the condenser, A, being placed between them. There are two high pressure cylinders, B, diameter 20 inches, stroke 30 inches, and two low pressure cylinders, C, with a diameter of 38 inches and a stroke of 30 inches. The low pressure cylinders are jacketed. Short connecting rods, D, from the crossheads, are attached to two bell crank levers, E, which have a throw of 27 inches. The crank connecting rods, F, are attached to the other ends of these bell crank levers, and to a common pin in the driving crank, G, which latter crank has a throw of 15 inches. The valves (not shown in the sketch) are on top of the cylinders, and are operated by eccentrics working on an intermediate shaft which is actuated by levers from the crossheads. No links are fitted to the valve gear of these engines, as the revolution always takes place in one direction, whether the ship is going ahead or backward. It will be observed that the propeller shaft, H, is vertical, the wheel employed being what is known as the Fowler patent. This can be described as a Manley feathering paddle wheel

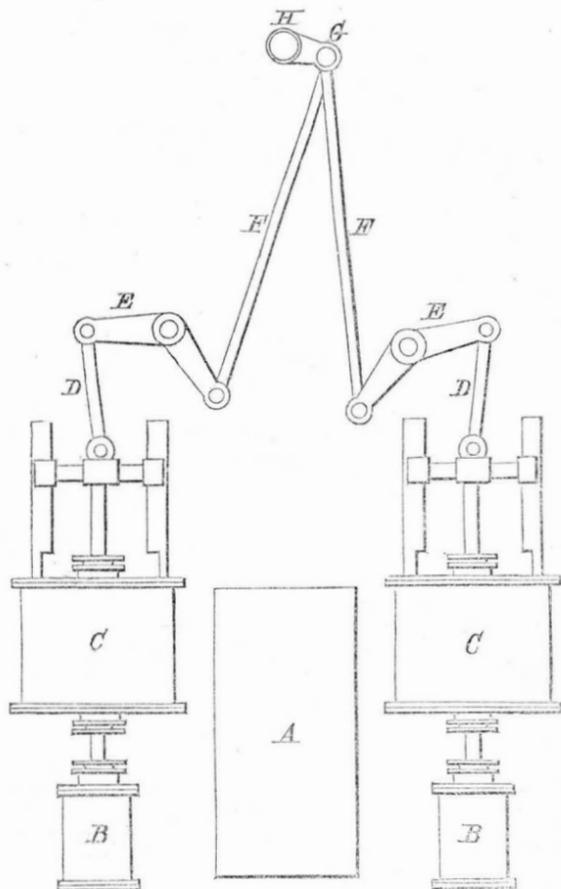

placed on its side, the position of the feathering eccentric being adjustable by hand. By shifting this eccentric, the vessel can be steered without the aid of a rudder, and can be propelled ahead or backwards, without reversing the engines. The diameter of the wheel is 10 feet. The air and circulating pumps for the condenser are independent steam pumps, of the Blake patent. There are four cylindrical tubular boilers of the type ordinarily fitted in modern ocean steamers. Each boiler is 10 feet in diameter and 11½ feet long. The total heating surface of the boilers is 4,600 square feet, and the grate surface, 170. The diameter of the smoke stack is 6 feet. Superheaters are placed in the common uptake of the boilers. The machinery described above, with the exception of the propeller, was built at the Morgan Iron Works, in this city.

THE SUN'S DISTANCE AND HOW IT IS MEASURED.

One of the simplest problems in applied trigonometry is to find the height of an inaccessible object. The solution involves the measurement of a base line and the angles formed on it by two lines connecting its extremities with the object whose elevation is to be found. For example, suppose the object to be a balloon. If at the same moment two persons, in line with the balloon and a considerable distance apart, make a note of its angle of elevation, the angles thus obtained, with the distance between the observers, are all the data required for calculating the height of the balloon above the earth. In like manner, if two observers, say, one at Washington and the other at Lima, or one at Paris and the other at the Cape of Good Hope, observe the position of the moon's center at the same moment, they will have two angles of a triangle, which, with the included side—the distance between the observers,—will enable them to determine the length of the remaining sides of the triangle, that is, the

distance between either station and the moon. In this case, the triangle is extremely long and narrow, the longer base line mentioned giving an angle at the moon of only about a degree and a half.

It is obvious that an object much farther off than the moon would give, with any base line obtainable on the earth, an angle too small for direct measurement. In the case of sun, for instance, the distance is so great that the nicest observation fails to show any measurable difference in his position, whether he is viewed from one or another part of the earth's surface. The determination of his distance must therefore be by other means than by direct triangulation.

Several ingenious attempts were made by ancient astronomers to solve this problem of the sun's distance indirectly, but the limits of error by their method were so wide that the results obtained by them had no value even as approximations. Indeed it was not until Kepler discovered the proportions of the solar system that it became possible to attack the problem with any hope of success. As soon, however, as Kepler's third law made all the distances of all the system calculable as soon as one was exactly known, it was clear that, if the distance from the earth to one of the nearer planets, say Mars or Venus, could be found, then a simple proportion would give the distance of the sun.

Mars was the first planet to be studied for this purpose. Venus approaches nearer to the earth; but as her orbit lies within that of the earth, her position during her periods of conjunction is unfavorable for observation, save at remote intervals when she happens to be exactly in line with the sun's disk, that is, during her transits. Of these more hereafter. Since Mars, when nearest the earth, is still too far away to be reached by direct triangulation—that is, so far that two lines connecting the extremities of the longest base line to be had on the earth with the planet's center would be so nearly parallel that the angle of their convergence could not be directly measured—it is obviously necessary to devise some other means of discovering the value of that important angle. Omitting all but the fundamental elements of the problem, the plan adopted may be roughly illustrated as follows: Hold a small object, say a pencil, steadily at arm's length and note the spot on the wall which the pencil point covers when looked at with the right eye, the left being closed. Now close the right eye and look at the pencil point with the left eye. Its position is shifted to the right, more or less according to the distance of the pencil from the eye and from the wall. The amount of this shifting, in angular measurement, may be called the pencil's parallax.

Suppose that, instead of being held between the eye and a wall, the pencil is placed before the moon at such a distance from the face that, when looked at with the right eye, its point covers the left horn of the moon, and, when seen with the left eye, the right horn. We may now imagine two similar triangles: one having for its base the distance between the eyes, and for its sides two lines proceeding from the eyes and meeting at the pencil point, the other formed by the prolongation of the same lines to the opposite sides of the moon's disk. The measure of the vertical angle of the triangle standing on the moon's diameter is the portion of the great circle of the heavens covered by the moon, that is about half a degree. The vertical angle of the triangle having for its base the distance between the eyes is the same; hence the remaining sides of the triangle—that is, the distance of the pencil from either eye—can be determined by a simple process of calculation.

Precisely the same principles are involved in the determination of the distance of a heavenly body like Mars, the displacement of the planet, as seen from two distant observatories, being measured with reference to some star lying as nearly as possible in the same direction. (Since the distance of a star is so extremely great that its position is not appreciably altered by any difference in points of view possible on the surface of the earth—in other words, since the star has no parallax—it answers perfectly as a fixed point of comparison.) As soon as the distance of the planet has been calculated, the distance of the sun can be determined by an application of Kepler's third law. Kepler made the calculation on the basis of Tycho Brahe's observations of Mars; but owing to the rudeness of those observations, he could only say that the sun's parallax could not be greater than one sixtieth of a degree (1') which would make his distance not less than thirteen and a half million miles.

Subsequent observations of greater exactness enabled Cassini to calculate that the sun's parallax could not exceed ten seconds of arc (10'') and he was confident that it was not greater than 9.5'', corresponding with a distance not less than 85,500,000 miles. The establishment of more widely separated points of observation, and the immense improvement made of late years in the construction of astronomical instruments, have enabled modern observers to make great improvements on these figures, which will be noticed directly. In the meantime, however, the transits of Venus in 1761 and 1769 furnished data for another and entirely different set of calculations.

The importance of the transits of Venus hinges on the fact that at such times the planet appears as a black spot on the sun's disk, so that her position can be observed with great exactness. The conditions which serve to complicate the problem are too numerous and complex to be taken into account here. The apparent position of the planet on the sun's face at any given moment of her transit necessarily depends on the position of the observer. The amount of such displacement is the essential term for calculating the distance of the planet, and from that the distance of the sun.

The observations made during the transit of 1761 were interpreted as giving a solar parallax of 8.65'', corresponding to a mean distance of about 94,500,000 miles. More elaborate preparations were made for the observation of the transit of 1769; but the conditions were less favorable, the observers were unprepared to meet a grave difficulty which arose, and the results were exceedingly discordant. Some made the sun's distance nearly 109,000,000 miles, others less than 88,000,000. About fifty years ago, Encke re-examined the observations made on both transits and, combining results, deduced the distance 95,174,000 miles—an estimate which was accepted as the best that could be hoped for until the transit of 1874 should furnish data for a new determination. It could not hold its ground, however, in the light of modern science.

From a study of the perturbations of the moon depending on the position of the sun, Laplace had deduced a solar parallax closely corresponding with that subsequently obtained by Encke from the transits of Venus. But in 1854 Hausen applied the same method to a larger number of more exact observations, and obtained 91,650,000 miles for the sun's distance.

By another method, depending on the apparent motions of the sun, Leverrier calculated a solar distance of 91,330,000 miles. Mr. Stone, of Cambridge, Eng., discovered a numerical error in Leverrier's work, and, on correcting it, made the sun's distance 91,739,000 miles. By the same method, our own Professor Newcomb obtains 92,500,000 miles. Foucault, by an experimental study of light, obtained results which would make the sun's distance 91,400,000 miles. Applying improved methods to the study of Mars, several astronomers, including Newcomb, Stone, and Winnecke, obtained, between 1860 and 1864, slightly varying figures approximating 92,000,000. It was clear that Encke's estimate was too great. Thereupon the observations of 1769 were subjected to another scrutiny with results so clearly confirming the later and smaller estimates that the distance, 92,000,000 miles—with a margin of possible error of 500,000 miles—was provisionally adopted. The finer instrumental and other appliances, which will be brought to bear on the transits of 1874 and 1882, will no doubt establish an exacter estimate, which it may take centuries to improve upon.

SCIENTIFIC AND PRACTICAL INFORMATION.

NEW ROUTE FROM NEW YORK TO LONDON.

A quicker route from New York to London is suggested, to wit: By rail to Shippegan, on the Gulf of St. Lawrence, thence across the Gulf by steamer to St. George's Harbor, Newfoundland, thence by rail to St. John's, thence by steamer to Valencia, Ireland, thence by rail to St. George's Channel and by steamer to England. The time of this route can be reduced to seven days three hours, the longest water steaming being 4 days, to wit, St. John's to Valencia, 1,600 miles. At the present time, from 10 to 12 days is occupied by the fastest steamers in sailing from New York to Liverpool.

POISONOUS COBALT COMPOUNDS.

According to some experiments of Siegen, the compounds of cobalt are to be reckoned among poisons. This savant experimented with the nitrate and chloride of cobalt, and found that one sixth of a grain of either substance would kill a frog in half an hour, and five grains killed a strong rabbit weighing over 3 lbs. in three hours. The poison seems to act directly upon the muscles of the heart. A frog was poisoned whose heart had been previously exposed, and its contractions became from 50 to 25 per cent less frequent; and after five minutes it stopped, and mechanical scratching failed to produce any farther contractions. With rabbits 1.66 grains produced a strong dyspnea, and the pulse fell from 178 to 128 per minute.

POWER OF EXPLOSIVES.

Some experiments have been made recently in a German iron mine at Hamm, to ascertain the relative efficiency of powder and some of the nitro-glycerin compounds for blasting purposes. The following were the results obtained:

Ordinary saltpeter gunpowder, 1 unit of force; extra best powder, with excess of saltpeter and cherry tree charcoal, made by L. Ritter at Hamm, 3 units; dualin, obtained from Herr Dittmar, lieutenant of artillery, Charlottenburg, 5 units; lithofracteur, from Krebs & Co., Deutz, 5 units; colonia powder (a sort of powder saturated with 30 to 35 per cent nitro-glycerin) 5 to 6 units; dynamite, 6 to 7 units. It will be seen that dynamite far exceeds the others in power, and its use is displacing theirs in German mines.

THE TRANSATLANTIC CABLE AND PLANET NO. 131.

An example of the free transmission of telegraphic dispatches relating to astronomical discoveries was presented on the occasion of the last new planet (No. 131), discovered at Washington on May 26 and observed at Marseilles on May 27 of the present year. The news was received by Atlantic cable and telegraphed from Paris to Marseilles in the following cabalistic terms: "Planet, sixteen, fourteen, south, twenty-one, eighteen, movement, right, west, eleventh." This, being interpreted, means: "A planet has been discovered, of which the right ascension is 16 h. 14 m., and the declination, southerly, 21° 18': its movement is directly toward the west, and it is of about the eleventh magnitude." It is an odd coincidence that the first planet discovered in America (during the year 1854) was No. 31, so that this last new comer, No. 131, also first noted in this country, is the hundredth found since.

TO REMOVE PAINT.—Chloroform will remove paint from a garment or elsewhere, when benzol or bisulphide of carbon fails.

CONCRETE SIPHONS ON THE CANAL QUINTINO SELLA, LOMELLINA, ITALY.

The importance of concrete made water cement, as a substitute for brick or stone in the construction of hydraulic works, is now beginning to be more fully recognized by Italian engineers. A few notes on some important works of this class that have recently been carried out for the Canal Cavour Company on the extension of the branch canal Quintino Sella, will not fail to prove interesting to our readers. In consequence of the scarcity of bricks, and the short time (four months) that was allowed for the construction of this canal, the company determined to accept the proposal of Signor Giuseppe Frattini—who has successfully introduced the use of cement concrete into Italy for the construction of hydraulic works—to build all the siphons for the passage of existing irrigation channels under the new

The dials are ten feet in diameter, each hour being cut in relief from a single block of stone. The hour hands are four feet in length, and the minute hands about five feet four inches. The clock is forty feet above the dials, and the movements of the hands work through long tin tubes encased in oak. There are in the clock tower three large cylinders, carrying steel and brass cog wheels, the largest wheels being two feet six inches in diameter, and the smallest being seven inches. In all there are twenty seven wheels, not counting the friction rollers. The pendulum rod is made of wood, twenty-one feet in length, and having at the lower extremity about five feet swing. In this there is a trade secret. Wood shrinks sideways, while iron, steel, brass and other metals shrink in all directions. Therefore wood, well seasoned and waxed, is used for tower clock pendulums. Three weights are used, hung at the ends of

H. The latter then rotates in the direction of the arrow on the right of Fig. 2. To reverse the revolution, the cylinder is carried over to engage with the opposite wheel. The valve, E is consequently rotated in the contrary direction, compressing the air in the annular chamber, K, which slowly escapes by the small orifices, *i i*, in the wing, F, thereby filling the free space formed in rear of valve, E. The rotation of the cylinder continuing, the pressure on F augments and can be rendered as strong as desirable by regulating the size of the escape orifices; so that, in fact, the reverse motion of the cylinder may be gradually started by the confined cushion of air, before the valve comes in contact with the opposite side of the wing. The latter, with the valve, may of course be suitably packed so as to ensure the air escaping from no points except the apertures, *i i*.

This device, though open to objection, principally through

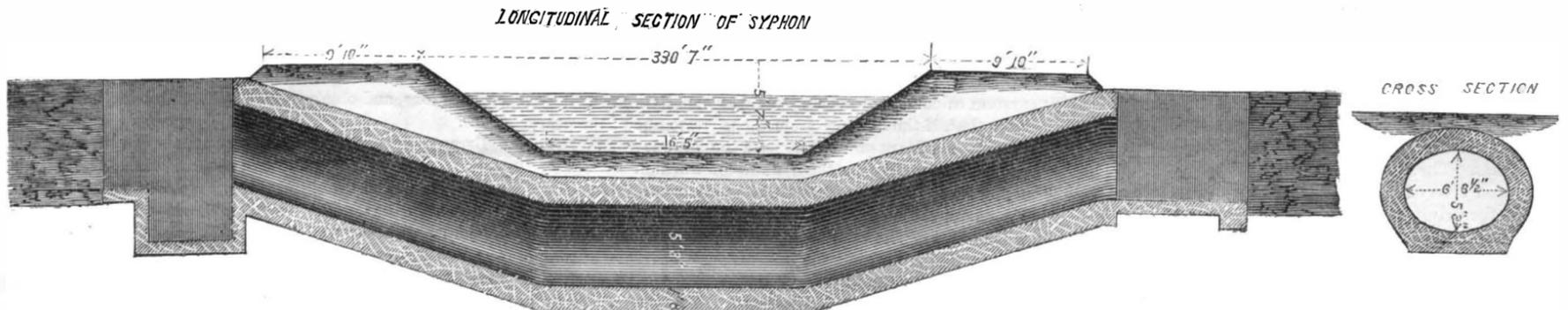

CONCRETE SIPHONS FOR CANALS.

canal in this material. This system of construction is exceedingly simple, requiring no skilled labor, and, when ballast can be had easily, is far cheaper than brickwork, and probably more durable. The cement used was that manufactured at Grenoble, and known as "ciment de la porte de France," the quick setting quality—*à prise prompte*—being mixed with the slower setting quality—*à prise lente*—or so-called Portland cement, manufactured at the same place. The mixture of the rapid setting quality with the Portland is for the purpose of making the work set quicker than it would otherwise do were only the latter used. The proportions in which the two qualities of cement are used should be regulated according as it is required to hasten the setting of the work, so as to be enabled to draw the core and carry forward the molds. It must be borne in mind, however, that the addition of the quick setting cement tends to weaken the cements, and should not be used in greater quantity than that absolutely necessary. The sand and cement are first mixed with water, the requisite proportion of gravel is then added, and the liquid concrete is poured round a wooden core supported by two molds placed about 6 feet apart, and of the exact section of the work to be executed. Lagings are placed round the external diameter of these molds, and the concrete is well rammed in the space thus formed between the outer casing and the core, this latter being drawn forward as the work proceeds. To facilitate the drawing forward of the core it should be made slightly tapered, and in order to obtain a truly cylindrical section in the concrete tube it should be covered with a plate of sheet zinc, which is kept in place by small wedges. On drawing the core these wedges fall out, and the sheet of zinc that remains behind can then be easily removed. The sand and ballast should be clean; and when easily obtained, the granite chips from a stone cutter's yard add considerably to the strength of the work. The tube being completed to the required length, wingwalls are then added of any required dimensions, and in this manner a monolithic mass of concrete is formed, which, a few hours after completion, when struck lightly with a hammer, rings like a bell. The siphons constructed by Signor Frattini on the Quintino Sella canal are fifteen in number, of which eleven were of a circular form, varying in diameter from 0.25m. (9.8 inches) to 1.00m. (39.1 inches), one double siphon, of which each tube is 0.80m. (26.24 inches) in diameter, and three of oval section, 2.00m. (6 feet 6 inches) in width by 1.60m. (5 feet 8 inches) in height (*vide illustration*), probably the largest works of this class that have ever been made. For building these siphons movable cores were not used, as the difficulty in drawing them forward would have been too great, and it was thought preferable to form the invert in the usual manner, building the arch afterwards on centering, which was struck as soon as finished, and set up again for building the next length. Signor Frattini is now in treaty for carrying out a colossal work of this nature, which will surpass in boldness anything that has hitherto been made in cement. This work will consist in a double siphon about 100 meters (330 feet) in length, each tube being of the same dimensions shown in illustration. This siphon is intended for carrying the water of a canal derived from the river Sesia under a tributary torrent for supplying motive power to a large paper mill near the village of Serravalle, Val Sesia.—*The Engineer*.

The Clock of Trinity Church.

One of the largest and best tower clocks in this country is that of Trinity Church, Broadway, New York. It was made in 1846 by James Rogers, and is a splendid specimen of horological workmanship.

heavy, seasoned ropes. The largest is on the hour hand, and weighs 125 pounds. Bales of cotton are on the lower floor of the clock tower, so that if the ropes break the weights shall not fall into the body of the church. By a simple trip leverage, three bells in the chime are connected with the clock, and thus ring out the quarter hours, repeating on the last two quarters. Another lever tolls the hours. The clock is wound up once a week, taking two hours each time to raise the heavy weight from the cotton bale to the top of the works. To economize labor, a patent winch is used to perform this work.

REVERSING GEAR FOR ROLLING MILLS.

In order to effect the reversal of the motion of the cylinders of rolling mills easily and without shock, M. O. Reichembach has recently devised the invention herewith illustra-

the weakening of the arbor by the mortise, seems nevertheless of considerable merit, and serves to exemplify an idea doubtless susceptible of extended application.

Hydraulic Fireworks.

At the Peterhoff Palaces, Russia, they have spray wheels mounted on posts, after the manner of the firework wheels. The spray wheels are driven by water pressure, and on turning they throw out beautiful streamers of water, which, when illuminated by sun light, or at night by colored lamps, present a most beautiful appearance.

Water pipes are also conducted through the branches of artificial trees, and splendid effects produced by the discharge of water in fine jets from the many branches.

A New Blue.

When phenol is treated with chlorine water, no reaction is observed, and ammonia added to the mixture subsequently develops no coloration. It is known that aniline, on the contrary, suspended in water, with the addition of a solution of chlorine, takes a rose color, which rapidly becomes purple, violet, and, lastly, brownish red, and that ammonia added at this last juncture increases the brownness. It is no longer the same when a mixture of a drop of phenol and a drop of aniline is submitted to the action of solution of chlorine. A permanent rose red is obtained, which may be turned to a blue either by ammonia or by the alkalies or alkaline carbonates. Acids restore the original redness. The author concludes that there exists a phenate of phenylamin; that the new body produced in the above reaction is a red acid, forming blue salts; the erythrophenate of soda may be produced by causing hypochlorite of soda to act upon the mixture of phenol and aniline. The blue thus formed is remarkable for its purity and extraordinary tinctorial power. If two drops of the mixture of phenol and aniline be added to two liters of water, and then treated with hypochlorite, the blue in an hour or two becomes so intense that it could be recognized even in 4 liters of water. This reaction may be useful in toxicological researches either for aniline or phenol. The purity and permanence of the blue might render it fit for the uses of the dyer, but it will not bear steaming. The extreme facility with which it is reddened by the feeblest acids is likewise an objection. In this respect it far exceeds litmus.—*E. Jacquemin*.

Artificial Ivory

Two pounds of pure india rubber are dissolved in thirty-two pounds of chloroform and the solution saturated with purified ammoniacal gas. The chloroform is then evaporated or distilled off at a temperature of 185° Fahr. The residue is mixed with pulverized phosphate of lime or carbonate of zinc, pressed into molds and cooled. When the phosphate of lime is used, the resulting compound partakes in a great degree of the nature and composition of genuine ivory, for we have the requisite proportion of the phosphate, and the india rubber, which takes the place of the cartilage; and the other component parts of the genuine article are of little importance.

THE railway tunnel of the West Side Railway, Hudson River, is now being pushed under the grounds of the United States Military Academy, West Point, N. Y. About 250 feet of tunnel have so far been cut.

THE *Railroad Gazette* estimates that the extent of new railways built in this country in 1873 will be more than forty per cent less than for 1872.

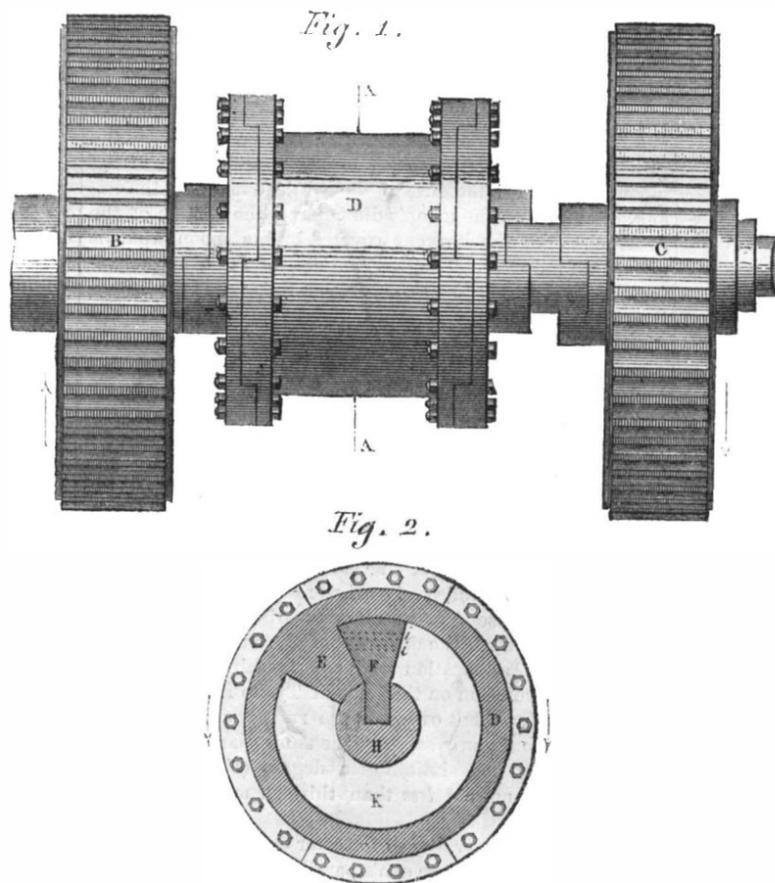

REVERSING GEAR FOR ROLLING MILLS.

ted, the engravings and description of which we extract from the Belgian *Bulletin du Musée*:

B and C, Fig. 1, are gear wheels which move freely in opposite directions upon the arbor, H. The cylinder, D, carries clutch couplings, which, as shown in Fig. 1, may engage with either wheel; for which purpose, the cylinder is capable of longitudinal motion along the arbor, H, around which it also revolves. E, in Fig. 2 (a sectional view through the line, A A), is a lug secured to or formed upon the inner surface of the cylinder, and fitting closely against the periphery of the arbor. The latter carries a steel wing, F, which bears against the interior of the cylinder and slides longitudinally in a mortise cut in the arbor, so as to follow the movement of the cylinder when the latter is transported, in either direction, to engage with one or the other wheel.

On power being applied, the motion of the toothed wheel is imparted to the cylinder, and from the latter (through the medium of valve, E, acting against the wing, F,) to the arbor

NATURE AND ART.

Conversing recently on the inborn genius of all true artists, and the futility of attempting to supply Divine gifts by a forced educational training, an eminent sculptor of our acquaintance remarked that he had really learned very little from his instructors, in fact, that he never had a master.

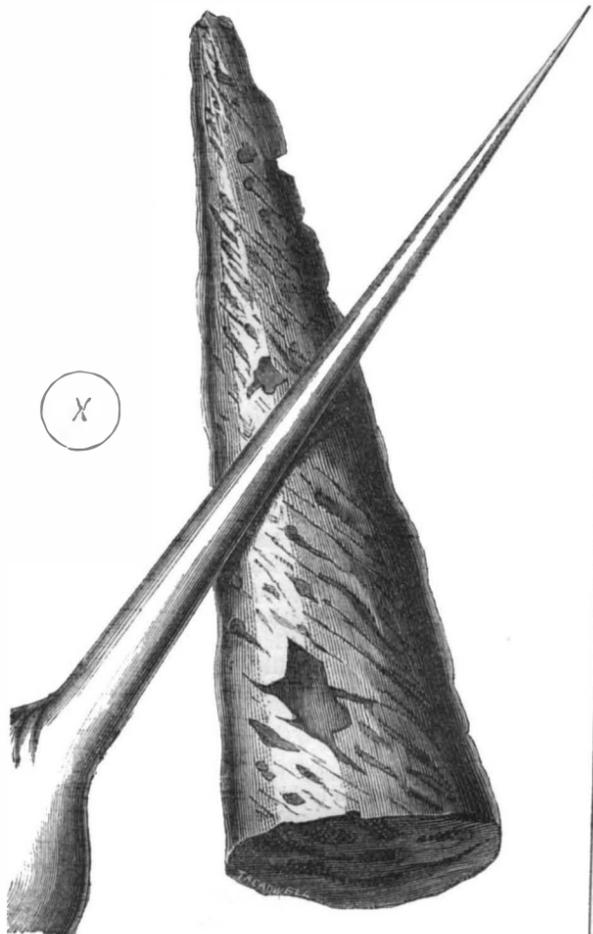

A fine cambric needle and the sting of a wasp, under a microscope.

We replied that we could name his master; and when he surprised, asked the name, we said: "Nature." He at once agreed and acknowledged that the artist is always learning in Nature's school. Painters give the same testimony, and admit that, for instance, the highest achievement of the greatest landscape painter falls far short of the reality. The strongest proof, however, of Nature's superiority is found in the accuracy of her handiwork. If we critically examine a human production, and compare it with the result of Nature's mysterious manipulation, we are amazed beyond conception. Take, for instance, the point of the finest cambric needle, and place it under the microscope with the sting of a bee or wasp: the apparently polished and pointed needle will then look like a rough, blunt bar, which, in fact, it really is; but the deficiency of our vision prevents us discovering this, while by help of the microscope we become able to perceive the truth. What, however, does this powerful aid to our vision reveal in regard to Nature's similarly shaped product, the sting of the wasp or bee? It shows us that it is smooth and uniform in its tapering dimensions, and has a point so fine that the highest power of the instrument does not cause it to appear blunt, as is the case with the needle. In fact, it is the most perfect apparatus for the purpose for which it is intended, while our needles are only attempts to produce a sharp point, which the microscope shows us we cannot do. We give here an engraving of the appearance, in the microscope, of the two objects named; the drawing is taken from an ancient work of Lieberkühn, published in Germany in 1760.

The comparison of these

two objects is only a single illustration of a general fact, which the investigator of Nature observes everywhere. The anatomist is continually surprised and fascinated by the structure of the animal under investigation; he finds, not only that every part is exquisitely adapted to its purpose, but that this fitness is carried into the minutest details, which the human eye can only unravel when aided by the powerful modern microscope.

THE DEVIL FISH.

There has always been a certain fascination about the marine monsters of the old mythologies; but modern researches in natural history have played havoc with the authenticity of many of these legends, and the *See Polyp, octopus*, or devil fish, is almost the only survivor of the world of the prodigies who choked Laocoon and would have devoured Andromeda. Greek writers astounded their readers with accounts of *octopi* large enough to devour ships, and these and many other exaggerated stories have caused many persons to deny the existence of this animal, the rarity of which is a further excuse for incredulity. But the large aquaria erected lately at Hamburg, Germany, and Brighton, England, have each obtained a specimen; and the habits and configuration of the creature can now be easily studied.

The illustration here presented to our readers was drawn from life from the specimen at Hamburg, by Herr Karl Stelling, for the *Illustrirte Zeitung*, from which we produce it. The corporal economy of the creature is most peculiar. The body consists of two parts, one a bag, containing the stomach, etc., provided with two eyes, and the other a nucleus and eight arms, each tapering to a point. On the under side of these are seen orifices by which the fish can attach itself, by suction, to any living object, which would have little chance of escape. By rapidly extending and closing the arms, it can rise in the water with great force and even throw itself into a boat. In repose, it curls itself up and remains almost motionless in a corner; but its ferocity is to be seen in its incessant watchfulness and the constant state of nervous activity in its long sinuous appendages.

The species shown in our illustration exists in the Atlantic and Indian Oceans and the Mediterranean and Red Seas. The ordinary size measures two feet from tip to tip of the

arms, and there is no reason to believe that any larger than five feet now exist; but historians, otherwise credible, report the capture of some which measured forty feet.

Correspondence.

[For the SCIENTIFIC AMERICAN.]

Fresh Water Crawfish or Crayfish.

I was surprised, on examination, to find no mention made of our common crayfish in the works on crustacea in my possession. I have known this creature from youth up, and of

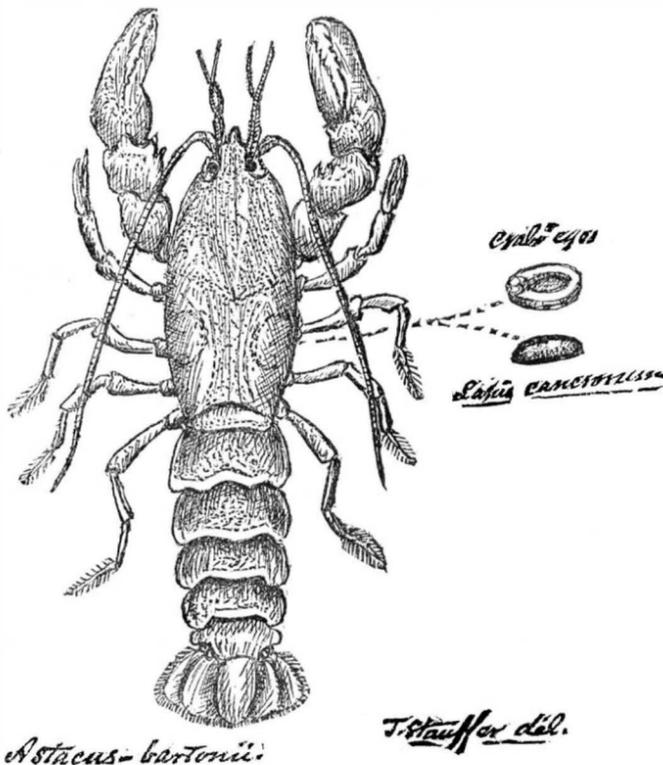

Astacus bartonii.

later years as the *astacus bartonii*—fresh water lobster. Sanborn Tenney, A. M., in his "Manual of Zoology for Schools, Scholars, and the General Reader," New York, 1865, page 463 (subject, *Macrurans*, the long-tailed decapods), simply mentions that the "*homarus* contains the American lobster, *h. americanus* (De Kay), which is from one to two feet long." With this meager information, he passes to the

gasturans or stomapods.

The accompanying figure represents the full size of our common species found in the streams, and I have seen them in the bottom of springs, in Lancaster county, Pa., and I presume they are equally common elsewhere.

My attention was called to this species by Squire Wright, of the Lancaster *Intelligencer*, who gave me two beautiful pearl-white, hard substances, flat on one side, with a central slightly depressed disk, the other side slightly convex, fully five sixteenths of an inch in diameter, of a circular form, smooth and hard as ivory or pearl, nearly one eighth of an inch in thickness. He informed me that he took these out of the body of a crayfish found crawling (and apparently sick) on the banks of the Conestoga, near Lancaster. Having been a druggist for over twenty years, I recognized these bodies, once in vogue as a medicine, and known to me as crabs' eyes, but why or wherefore, I knew not, as a druggist. However, as a naturalist of later years, I knew their source, so far as it regarded foreign species, but it was new to me to find they were so large and fully developed in our native species. Linnaeus classified the crustaceans among the insects; Cuvier and others clearly showed that they were as distinct from insects as a whale is from a fish, properly speaking. The crabs' eyes, called *oculi cancerorum* or *lapides cancerorum*, were formerly used in medi-



THE DEVIL FISH IN THE HAMBURGH AQUARIUM.

cine as a powerful alkali, or absorbent. Old authors supposed they were formed in the brain of the animal; Van Helmont first found them in the region of the stomach. M. Geoffroy the younger has observed the manner of their formation much more accurately: "While the shell of the crayfish, which is shed every year, is hardening, a white nutritious juice, secreted in two portions of the stomach, forms, by degrees, a soft calculeous substance, of a crustaceous texture, from successive appositions of the juice. Before the casting of the shell, the animal is in a weak and sickly state; it takes no food for some days, and in this period the calculi seem to serve for its nourishment; and on this account the crabs' eyes are met with only while the fish are losing their shells, and for a few days afterwards."

The prevailing idea is that these pearl-like bodies are cast off with the stomach and the old shell, and the old stomach is the first food the new stomach receives to digest; and it dissolves the crustaceous deposit, which goes to reproduce and harden the new shell, provided as a reserved accumulation, to meet the emergency. Much of interest to the naturalist is related and known about these scavengers of the sea and fresh water, as they are by no means choice in the selection of their food.

Although crustaceans, directly, do not greatly add to the supplies of our food, yet they indirectly assist very materially in contributing to our wants. The molting of a crab seems a mysterious process to the novice in natural history, who finds that the shell, a coat of stony hardness, which requires great strength to open, cut, or break, can be cast off entire—the joint of every part of its thousand jointed body, *antennæ*, foot, jaws, claws, and tail. And not only does it cast off these hard external parts, but the very linings of its gills, of its stomach, of its eyes, and other parts are thrown off, and thus, when the creature has escaped, the shell seems as perfect nearly as the animal itself. You may often meet with cases from the Brazils of a gaudy *grapsus* (more delicate even than the new coated animal, seeing the parts are translucent); these are the cast-off skins. Mr. R. Q. Couch, a most able naturalist, says "that he could never understand how that broad flat surface inside each claw could be got rid of without injury to the new claw; however, by attentively watching the process in several instances," he continues, "I observed that, in the act of drawing out the new claw, the edge is cut through by these flat horny plates, the divided parts immediately closing again, and speedily becoming so adherent as to preclude their being re-opened." Crabs, when they lose a claw, are said to get a new one at the next casting of the shell. Mr. Couch says: "This can take place only in the joint which is nearest the body; if any other be injured, they bleed to death; but if the nearest joint be removed, there is little blood lost, and over the wound a thin film forms, in the middle of which is a tubercle. After the shell is cast, the tubercle suddenly enlarges, and under it may be discovered a small claw doubled on itself beneath the membrane of the scar. This remains in a soft state until the crab again casts its shell, when the new claw is set at liberty, is straightened out, and becomes hard and calcareous like other parts of the body; so that a claw, instead of being removed and perfected at once, or at the first casting of the shell, is not so in reality until the shell has been cast the second time." That, in their contests with each other, they often lose their claws, there is no question. This will recall the amusing article devoted to lobsters, in Dickens' *Household Words*, July 29, 1854, where he says: "They are a kind of marine Muscovites, bristling with rage against every one—fierce, hard, horny, and pugnacious, always tearing and rending something, and losing their limbs with as much indifference as if they belonged to some salt water Czar."

The tail or, rather, abdomen of a lobster, the joints of which fold so beautifully on each other, suggested to James Watt the idea of a flexible pipe, which he constructed for some water company. Nature has given many valuable hints, which are worthy of study, for she is truly prolific in devices and adaptations to ends, as wonderful as they are marvelous, filling him who duly contemplates the matter with awe and adoration.

J. STAUFFER.

The Patent Right Question.

To the Editor of the Scientific American:

A citizen has a right to claim from the State only such protection in the use and ownership of property as shall redound to the public good. The exclusive right to use an invention is not for the public good; but as inventors, without some remuneration more than the personal use of the thing invented or the honor of being the inventor, might allow their powers to lie dormant, or be tempted to keep their inventions secret, the authorities of the State require the public good to be ignored for a term of years, for the benefit of the inventor, to encourage study and experiment; which study and experiment the State would have as much right to compel by direct legislation, were the enforcement of such laws practicable, as it has to compel military service when the welfare of the State demands it.

As every person in a lawless country could and would defend the possession of ordinary property by force, the public good demands there should be laws to enable men to do peaceably what, without law, they would do by force, and these laws follow more naturally from the fact that a large majority of every people are property holders of some kind. But an inventor is not prevented from the use of his invention by its being used by others, nor could he by force prevent this use by others of an idea he can never actually take possession of; and inventors being greatly in the minority, their interest must conflict with the public good.

The possession of ordinary property is the origin of law,

whereas the ownership of a monopoly is the creature of the law and could have no existence but for the law.

There is a wide difference between the two kinds of property, and the right to both cannot be claimed upon the same grounds.

H. A. WALKER.

Tarboro, N. C.

To the Editor of the Scientific American:

I cannot see that an inventor has any inherent right in his own discovery. Our own government has wisely seen fit to offer an inducement to inventors for the discovery or reproduction of any lost art which may be useful to the public. His reward is an exclusive property for a fixed term of years in the discovery or invention. It is only intended to grant this exclusive property to genius, and not to ordinary talent. Genius, being supremely greater than talent, originates and gives to the public that which was not before known; and still ordinary talent is better rewarded, pecuniarily, than genius. An inventor must of necessity be a genius; and he has a just and legal claim upon the public so far as the law enacts that he is to be protected in the ownership of his invention. So he directs his mind, occupies his time, and spends his money in order to receive the reward. Not, however, for the simple act of inventing, do the laws reward him. He must produce something that will enure to the public welfare; if he invents a device for burglarious purposes or for picking pockets or locks, or to aid in counterfeiting, the law does not allow him any property in his invention.

It is a prudential question as to how far a people should go in rewarding inventive talent. England has had a very costly experience in this direction. Millions of money have been spent in a contest of inventive ability between the Admiralty and the constructors of ordnance, between armor to resist and missiles to penetrate. This contest still goes on at the expense of the public. I cannot see that the inventor can set up any claim, except just so far as he benefits the public and the laws grant him a reward. But when it becomes a question of duty, every one is bound to exercise his talents for the good of mankind; and he is entitled to both a fair remunerative and appreciative reward, simply because such reward serves to stimulate like action in others, and not because he is entitled to reward; but because the public interest requires that he should be rewarded.

J. E. E.

Beaver Falls, Pa.

Sailing Faster than the Wind.

To the Editor of the Scientific American:

You recently told a correspondent that a boat might sail faster than the wind, if carried across the river by the force of the downward current. To me, this answer was not entirely satisfactory, as I knew by observation that rafts, boats and barges, floated down the river with the current, always ran faster than the water, and I cited the case of oil barges being run out of Oil Creek by pond freshets, which outran the water so much that they had to stop and wait for it. I then asked: Why was this so? I will give you my reasons for it.

A raft of boards is comprised of about 300,000 feet, board measure, and each foot weighs about 4½ pounds; so that a raft of 300,000 feet will weigh 1,425,000 pounds. Suppose that the fall in the river is at the rate of four feet to the mile, or one foot in 1,320 feet, an indirect plan is formed, upon which the inclination is 1 in 1,320; and the quantity putting force upon the raft would be $\frac{1}{1320}$ of 1,425,000 pounds, or something over 1079 pounds. A raft of boards running at the rate of five miles an hour does not meet with very much resistance from the air in a still day among the high hills of the Alleghany River. Would not this 1,079 pounds of constant gravity pull have tendency to make it sail faster than the water that carries it? I consider this to be a scientific question, and I would like to see something on the subject from men of science.

Cobham, Pa.

HENRY BAXTER.

Car Ventilators.

To the Editor of the Scientific American:

I recently noticed in one of our papers a description of a railroad car ventilator, that was submitted to the Car Builders' Association at their last meeting in this city. I do not recollect the name of the inventor; but the idea was to make the front of the car double, with openings at the edges covered with wire netting. I am not interested in any ventilator whatever, except that I desire to see the one introduced that will give us pure air; and I fear we shall not see that very soon, if the matter is to be left in the hands of men who advocate introducing "air through an opening over the door of the car," as appears to be the case on the Harlem railroad. Every one who has ever ridden on a railroad car knows that the dirtiest place on the whole train is between the cars. There is no trouble in ventilating a car; it requires no intricate machinery; just open the doors and all the windows, and the thing is done. But ventilation is not all we want, nor is it the principal thing; we want pure air, air freed from not only cinders but from fine railroad dust and ashes, which, inhaled by the breath, are quite as detrimental to health as vitiated air. Now for a person to assert that a ventilator containing dry wire netting, however fine, will admit fresh air to a car, and at the same time arrest railroad dust that is fine enough to permeate the closest woolen clothing, is, to my mind, simply absurd. From the very nature of the case, it is impossible to separate air and railroad dust without moisture; with moisture the thing is perfectly feasible, and, if inventors are inclined to give us pure air, the only possible way they can do it is to use moisture or else give us air taken from forward of the engine tender. But do not give perspiring humanity a dust-laden air, making them believe that it is pure because it comes through

wire gauze and double partitions with many intricate windings. We had better have the windows open and brush off the cinders which are the least of our troubles. The cars might be kept pretty free from impure air by giving us another employee on the train whose sole duty should be to see that all the windows on the leeward side of the cars were kept closed, and let what windows are to be opened be those on the windward side, and see that the doors are always kept closed except while the train is in motion. The great trouble is that passengers on the windward side close the windows because the air is too fresh and strong, while those on the leeward side open them and fill the car with smoke, dust and cinders, which are on that side only. If the windows were opened on both sides, the wind might perhaps blow through and keep the car clear. But perhaps the best way of all would be to cover the road bed with small stones to the depth of five or six inches, sow grass seed on the sloping sides of the cuts, and convey the smoke and ashes either above or below the cars and discharge them at the rear of the train. The speed of the train would give the draft required.

F. S. C.

Boston, Mass.

The Million Dollar Telescope.

To the Editor of the Scientific American:

Mr. Alvan Clark, Jr., of Cambridge, Mass., informs the writer that, at the rate of compensation paid for the Washington telescope (26 inch objective, \$50,000), the sum of one million dollars would pay for an equatorial telescope complete, of which the object glass would have a diameter of 5 feet 6½ inches in clear aperture and a focus of 75 feet.

When the air is very clear, a good achromatic will bear a power of one hundred for each inch of aperture. The aperture of the object glass being 66½ inches, the highest power will be 6,650 diameters. This will bring the moon within 34·58 miles, as the moon's mean distance=230,000 miles which ÷ 6,650=34·58 miles.

If, however, the object glass were perfect, and the atmosphere were of uniform temperature, we could apply a microscopic eyepiece $\frac{1}{30}$ of an inch focus; then the magnifying power would be 72,000, and the moon would appear within 3·19 miles. The drawings of the Great Nebula in *Orion*, made with the Harvard fifteen inch glass, show more detail than those made with the Parsonstown six foot reflector. Our great telescope, therefore, will be at least equal in performance to a reflector twenty-six feet in diameter.

S. H. M., Jr.

To the Editor of the Scientific American:

F. H. R. says, in his letter on page 100: "Of course the field would be divided by dark bands into polygonal sections similar to the object glass." Such would not be the case. The field would be unobstructed, its shape and size depending wholly upon the eye piece. There would be a loss in definition, in the use of such an object glass as compared with one of the ordinary construction, arising both from the reduction of the available aperture, and also from the reflection and diffraction of the rays of light coming in contact with the interior frame work of the object glass.

Slatersville, R. I.

A. F. KELLY.

To the Editor of the Scientific American:

I noticed recently on page 100 of your current volume, an article on the million dollar telescope, in which the writer says that, if the object glass be composed of seven pieces, one in the center and six around it, the field would be marked with dark lines corresponding to the joints. I can show it to be otherwise.

If you put an opaque disk in the place of the object glass, a screen in the field or in place of the eye piece, and pierce the disk, you get an image opposite the aperture on the screen. Another hole would form another image. With seven holes, one in the center and six around it, you would have seven images with dark bands between them. If you put a glass in the center, the corresponding image is only made more distinct; but one put at the side not only makes the image clearer, but also throws or deflects it towards the central one so that they correspond. Each one would be thus brought into the center and the shadow of the joints would not appear.

New York city.

CONVEX.

"For Inventors and Mechanics."

Messrs. Munn & Co.:

GENTLEMEN:—Please accept my thanks for a copy of your inestimable little handbook for the current year, embodying a copy of the United States Patent laws, with many valuable hints and instructions to inventors. Its one hundred and forty illustrations of mechanical movements are well calculated, and will undoubtedly, in many instances, save the young and old inventor many a weary hour of brain racking.

It is invaluable to inventors as a pocket companion. Let me know its price, including postage, as some friends who have seen it are desirous of getting a copy.

Houston, Texas.

J. J. MARTIN.

TO RESTORE COLOR.—When color on a fabric has been accidentally or otherwise destroyed by acid, ammonia is applied to neutralize the same, after which an application of chloroform will, in almost all cases, restore the original color. The application of ammonia is common, but that of chloroform is but little known.

THE yellow pine, an invaluable building material for bridge and car work, is being rapidly thinned out in the South. No tree of this kind grows afterward where one is cut, but only a worthless scrub pine of another species. Those who now set out new plantations of these trees will in a few years find them very valuable.



THE GREAT EXPOSITION—LETTER FROM UNITED STATES
COMMISSIONER PROFESSOR R. H. THURSTON.

NUMBER 7.

VIENNA, July, 1873.

The number of visitors entering Vienna seems to increase slightly as the increasing warmth of the season drives tourists northward from Italy. Rome and many other of the more interesting cities of the peninsula become extremely unhealthy, as the heat of summer begins to produce putrefaction and decay wherever organic matter is left exposed to the air; and miasmatic emanations, thus set free to contaminate the atmosphere, produce a class of diseases, of which fever and ague, the dreaded Roman fever, and the still more dangerous yellow fever, are examples. The prevalence of such diseases in Southern Europe this season is attracting comparatively little attention, however, as occasional outbreaks of the cholera, here and there, distract the attention of the people, and give warning that a vastly more dreadful disease may become epidemic, if not provided against with the greatest possible care.

Cases of cholera occur in Vienna daily, but they are not usually of the Asiatic type. The government is taking every precaution against the entrance and the spread of the disease. The police are compelled to watch for cases of sickness and to remove at once to the hospital any person ill with cholera, or with any contagious disease. The use of disinfectants throughout the city is compulsory, and the police are charged with the supervision both of public streets and of private dwellings. Men are detailed to distribute disinfecting materials, and to see that they are actually used. Where such precautions are taken to keep a city thoroughly clean and to guard against the importation of disease, it may be confidently anticipated that no disease will become epidemic. Unless the action of the authorities of New York during the present summer is in marked contrast with that taken during those which have preceded, Vienna is far more cleanly and is far better fortified against epidemic diseases than is our own metropolis.

Some other European cities are equally well cared for. The city of Dresden is an example. During the past month, it is officially reported that 36,614 pounds of disinfecting powder have been used by the police of that city, and 34,318 pounds of sulphate of iron and carbolic acid. The dreaded disease has entered the neighboring villages, but the newspapers to-day report that no cases have occurred in the city itself for many days.

It begins to appear probable that our own country will be compelled to learn by experience the importance and the necessity of making special provision against epidemic diseases a matter of municipal and governmental action. It would be far more economical and more satisfactory to learn from the experience of European cities.

At the *Welt-Ausstellung* there is no change observable in the number of visitors. Those departments in which are exhibited the finest works of art are always crowded, while those in which are to be seen objects of less interest have comparatively few visitors. The magnificent collection of

PRECIOUS STONES AND JEWELRY

in the French Department is naturally very attractive, particularly to the ladies, and is really wonderful in the variety and richness of the display.

The French excel in all such work, and wherever delicate workmanship, elegant design, and richness of decoration go together. One of the most attractive cases in the French section is that in which are displayed the automaton birds. A number of small cages contain each a bird, whose lifelike attitudes and motions and melodious songs almost convince the visitor that the card indicating the fact that they are automatons is placed here by mistake. However, the general rule that beautiful plumage and the power of singing well are not conferred by Nature upon the same individual, and the prices asked—from 250 francs (\$50) upward,—are good evidence on the other side.

The French are well represented by their artists and quite well in

SCULPTURE,

but, as might be expected, the finest statuary is from Italy. The space assigned to the latter country contains a large number of excellent contributions, either by her own or by foreign artists resident there. One of those which, together, constitute a group forming a circle in the middle of the

main building, is to many one of the most interesting objects in the exhibition. It represents the Egyptian girl presenting the infant Moses to the princess. The face of the girl is characteristically Egyptian, yet beautiful and full of expression. Her form and her attitude are equally graceful and natural, and the admiring spectator is almost persuaded that she is about to step forward and tell her story. The child is equally well represented. The boy half reclines in the ark of bulrushes, one little hand grasping its edge, and, with head raised, looks earnestly forward with an expression upon his face which can be interpreted either as indicating the child's prophetic vision of his coming life with its great work, or an earnest effort to read in the face of the princess some assurance of a kind reception. The features remind one strongly of the child's face in one of Raffaele's paintings of the Madonna. This work of Barzagli has rarely been equalled by any sculptor of ancient or modern times.

From the Industrial Palace, I have been accustomed to go to the Machinery Hall through the British Agricultural Department, where are exhibited some exceedingly fine examples of agricultural machinery, and where I have been particularly interested in the display of

PORTABLE ENGINES,

a branch of steam engine construction, in which, as in compound marine engines, our transatlantic cousins have decidedly taken an important step in advance of us. We have very few builders of portable engines in the United States who produce machines of fair design, good workmanship, and even moderately satisfactory performance. It is also true that but few British builders place really creditable machines in the market. Yet the majority of the best builders of Great Britain have produced portable and agricultural steam engines which exceed very greatly those constructed by the majority of the best known builders in the United States.

At the annual exhibition of the Royal Agricultural Society, the premium for the most economical portable engine has, during late years, been given to the victor at a competitive trial made under the rules of the society and under the superintendence of competent judges appointed by the society. At these trials there is, as a matter of course, some "jockeying," but it may be assumed, with some probability of correctness, that the most skillful half dozen builders are likely to be the most skillful half dozen jockeys, and the results will serve very well as indications of the degree of perfection reached by them. The horse power is determined at these trials by the dynamometer as well as by the indicator, and, taken altogether, the reports afford exceedingly valuable contributions to engineering knowledge and literature. In some instances, the dynamometrical horse power has been obtained by the expenditure of but from two and a half to two and three quarters pounds of fuel per hour by the best machines, while some of their competitors expend five pounds or even more. These remarkable results are obtained only by the most careful preparation for, and conduct of, the trial. The engines are built in the most careful manner and are frequently kept under an informal trial for weeks before being sent to the exhibition for competition. Every fault is thus discovered, and the attendants are also thus made thoroughly trained "jockeys." On the trial, the fuel is handled as if it were worth its weight in gold. Every piece goes into the furnace at the right time, and is thrown upon precisely the same spot on the grate. The feed water is uniformly supplied and enters the boiler heated by the exhaust steam to the highest possible temperature. The draft is carefully regulated, and the steam pressure and the speed of the engine are kept as nearly as possible unchanged from the beginning to the end. It is not so surprising, to one who understands what wonderful effect such precautions have in saving fuel, that remarkable economy should thus be attained, but it is not all due to management alone; much of this success is a consequence of excellence of design. It may probably be questioned whether any such engine, now to be found in the market and built in our own country, can compete successfully, under such circumstances, with some of these British built engines. While capable of teaching good practice in building stationary engines, we are capable of learning something in this humbler field. The machines exhibited here have such beautiful finish and are made of such exceptionally good material that we are probably justified in assuming that they are built to secure premiums, and that they do not represent in these particulars the average practice. They are, however, of standard design.

What may be termed the

STANDARD ENGLISH

portable engines, as built by the best firms, may be described as follows: The engine is mounted on the top of the boiler as in the usual style with our own builders. The cylinder is made with a steam jacket, and the valve gear is the ordinary arrangement of three ported valve, for small sizes, or the Meyer valve gear, in which the cut-off valves ride on the back of the main, in larger and more economical engines. Where provision for reversing it is necessary, the Stephenson link is used. At least one firm of high reputation have adopted the solid bar link, in place of the usual form of strap link. The readiness with which wear can be taken up, and its consequent comparative noiselessness and freedom from shock, also, are its advantages. The regulation is generally effected by the ordinary fly ball regulator operating a valve in the steam pipe. One firm uses the approximate parabolic regulator of Farcot; and in other cases a peculiar arrangement of governor on the crank shaft, by which it is made to alter the position of the eccentric, has been adopted, but whether successfully or not I am unable to state. The

governor is invariably attached. The very excellent practice of bending the crank shaft to shape instead of building it up is general. Provision is made by means of an ordinary harness buckle on the regulator belt, for tightening it at any moment. The boiler is of the ordinary locomotive type, with large heating surface and a liberal calorimeter. The steam enters the steam cylinder by passing through the steam jacket, which it reaches through openings large enough to allow the steam to pass without interference with the drainage, back into the boiler, of all water of condensation. The exhaust passes through a feed water heater of large surface area, and thence into the chimney. Engine and boiler are both thoroughly covered and guarded against losses of heat by conduction or radiation. This last point, as well as the steam jacket, is too often neglected by engine builders, and with less excuse.

The casting of a steam jacket with a cylinder involves the risk of obtaining a largely increased proportion of bad cylinder castings; and its construction separately, as it must be made with large engines, is a matter of some expense, to say nothing of the fact that but few designing engineers understand the "dodges" which seem essential to successfully unite the cylinder and jacket; but there is no excuse for carelessness in covering the boiler and the steam cylinder with protectors against loss of heat and consequent waste of fuel. Many good engineers doubt the efficacy of steam jacketing, but none doubt the expediency of a liberal use of non-conductors and non-radiators wherever heat is to be retained.

But no design, however perfect, will secure satisfactory performance unless it be embodied in good material by good workmen, and unless its management be confided to experienced and skillful men. In material and workmanship, some of these engines are probably as near perfection as any machines that have ever been produced, and that good men can be found to take charge of them is proven by the splendid performance already alluded to. The use of

STEEL,

for connecting rods and piston rods, and for crank shafts, is becoming quite general, and progress in this direction may be regarded as one of the most important changes here observable. The substitution of steel for iron is taking place very rapidly now that the new metal, with its greater strength and toughness and its homogeneity, may be secured without very much greater expense than is incurred in the use of the less reliable material. The general use of "low steel" for locomotive work is also equally general, and is observed by the most careless visitor; and among the most creditable exhibits in Group VII are numerous locomotive crank shafts of "homogeneous metal," of which the beautifully perfect and highly finished surfaces are in strong contrast with the streaked and welded examples, of similar constructions in iron, with which only we were familiar but a few years ago.

R. H. T.

Artificial Fibrin as a Diet.

Dr. John Goodman, in a communication to the *British Medical Journal*, says of artificial fibrin: "As a member of the British Medical Association, and in the common interests of humanity, I have much pleasure in calling attention to my discovery of this new dietetic substance. So far as I have employed it, it promises fair to be invaluable in medical practice, especially in cases of feeble alimentation and deficient nutrition, and second to none in those cases where rejection of food forms a prominent feature, or where the appetite and digestive powers are reduced to a minimum. As fibrinous material, it is of course highly nutritious, and eminently adapted to all cases where there is a deficiency of fibrin in the blood. It is, perhaps, unparalleled in its qualities of lightness and digestibility, and is, moreover, a great delicacy. In many urgent cases of rejection of food, etc., it not only remains where an egg otherwise cooked would not be tolerated, but its presence in the stomach has been found to create a feeling of want rather than of superfluity, and to promote rather than decrease the appetite for food.

The production of this substance is within the reach of every sick room, and is effected with great facility. It is formed by exposing albuminous material to the operation or influence of cold water, for a given period; and on account of its great plenteousness we employ the ordinary hen's egg for its production. When the shell is broken and removed, and its contents are immersed in cold water for twelve hours or so, they are found to undergo a chemic-molecular change, and to become solid and insoluble. This change is indicated by the assumption, by the transparent white of the egg, of an opaque and snowy white appearance, which far surpasses that of an ordinary boiled egg. The product, and the fluid in which it is immersed, must now be submitted to the action of heat to the boiling point, when the fibrin will be ready for use."

We will add that on trial we find that, for table use, the eggs thus prepared are most excellent, and this method of preparation will no doubt soon come into general use. Instead of boiling in the water in which the eggs are originally placed, they may be removed therefrom after standing twelve hours and put at once into boiling water.

Jeannel's Horticultural Fertilizer.

We are in receipt of several inquiries regarding the ingredients of an artificial fertilizer mentioned some time since in our columns, as devised and used with great success by Jeannel, of Paris. The recipe was translated *verbatim* from *Les Mondes*, as that journal extolled the performances of the compound in the most laudatory terms. The biphosphate of ammonia, which forms the stumbling block for many of our correspondents, should probably be phosphate of ammonia.

BRICK COMPRESSING MACHINE.

The constantly increasing demand for materials for fire-proof construction has recently directed much attention to the manufacture of pressed brick, and there seems to be little doubt that a well made, well burnt brick is the most thoroughly indestructible substance known. We extract from our contemporary *Iron* an illustration of a brick pressing machine recently invented by Mr. Henry Large, of London, Eng. The machine is to be driven by a steam engine or other prime motor in the usual way, by means of a belt and fast and loose pulleys on the shaft of the fly wheel. The belt is shifted by the fork and key handled sliding lever, as plainly shown, brought to the side of the machine where the attendant stands, so as to be readily accessible. On the shaft of the fly wheel there is also a small spur wheel, which drives the large one above, fixed on the second motion shaft. On the farther side of the large spur wheel there is a reciprocating cam, which actuates a horizontal bar by means of a stud pin. This horizontal bar is a bent lever, having on the end opposite the stud pin peculiar mechanism for working the compressing piston, the head of which is seen below the end cover. The large spur wheel carries on its front a friction cam roller on a stud axle, which actuates one of the arms of a double bent axial lever, the other arm being furnished at its lower extremity with a long friction roller for pressing forward the molds across the table under the compressing piston. On the right hand side is seen a second piston, for emptying the molds, by pressing the bricks down through a suitable aperture in the table, one at each stroke, on to a platen table, which forms the head of another piston seen below, which is raised by a weighted lever. The counter balance is not sufficient for the weight of a brick, so that the brick presses the piston down; and when it is removed by the attendant, the weighted lever again elevates the platen table to receive another brick. As the bent arm on the left hand side pushes the newly filled mold forward under the compressing piston, it at the same time pushes forward the mold with the newly pressed brick a stage towards the emptying piston (displacing the mold occupying that stage under the emptying piston) and the empty mold a stage forward; while a fourth piston, working horizontally, and actuated by a cam on the side of the large spur wheel, pushes the empty mold forward to be refilled.

In this way the machine works continuously, turning out from 5,000 to 6,000 concrete bricks daily, which are ready in three or four days for the builder, and fit for use; while the fire bricks and common clay bricks made thereby are turned out in a drier state than by the ordinary processes, and hence are sooner ready for the kiln, and at less expense.

These machines can be made for compressing two or more bricks at one and the same time by means of a corresponding number of compressing and emptying pistons.

The machine does not require skilled labor to work it. It can be driven by a common farm engine, water wheel, or horse power, so that laborers experienced in such are qualified to control the whole. When burnt ballast and sand are at command, bricks can be made on the spot where the buildings are to be erected, and used, on an average, three or four days after they are made; at the same time, the older they are the stronger, and they can be made at all seasons of the year, as they require no drying or burning. For water tanks, liquid manure tanks, and all buildings under water, concrete bricks are much superior to common ones. They can be made of any color, for ornamental work, more successfully than can common bricks, and they can be made of any shape, and perfect in form, for plain, arched, groined, and cornice work. Such machines, therefore, are admirably adapted for use on landed estates for building purposes, as well as for general builders and contractors.

Dining Table of the Emperor of Russia.

One of our correspondents now travelling in Russia sends us a description of the novel dining table of the Emperor, now in use in one of the Peterhoff palaces, near St. Petersburg. The table is circular and is placed on a weighted platform. At the touch of a signal like the rub of Aladdin's lamp, down goes the table through the floor, and a new table, loaded with fresh dishes and supplies, rises in its place. But this is not all; each plate stands on a weighted disk, the table cloth being cut with circular openings, one for each plate. If a guest desires a change of plate, he touches a signal at his side, when, *presto*, his plate disappears and another rises. These mechanical dining tables render the presence of servants quite superfluous. In this country, at the **Onaida** community, they employ dining tables having the

central part made to revolve. Here the goblets, spoons, tea and coffee, castors, pitchers and other necessary articles of table furniture are placed; revolving the center piece, the sitter brings before him whatever article may be desired without the intervention of a special waiter. The Russians

inches apart, a distance which may, by suitable means, be increased to fifteen inches. After chopping, the machine may be used as a cultivator. It is stated to be adjustable, in all its parts, simple, strong and durable, of light draft and easily guided.

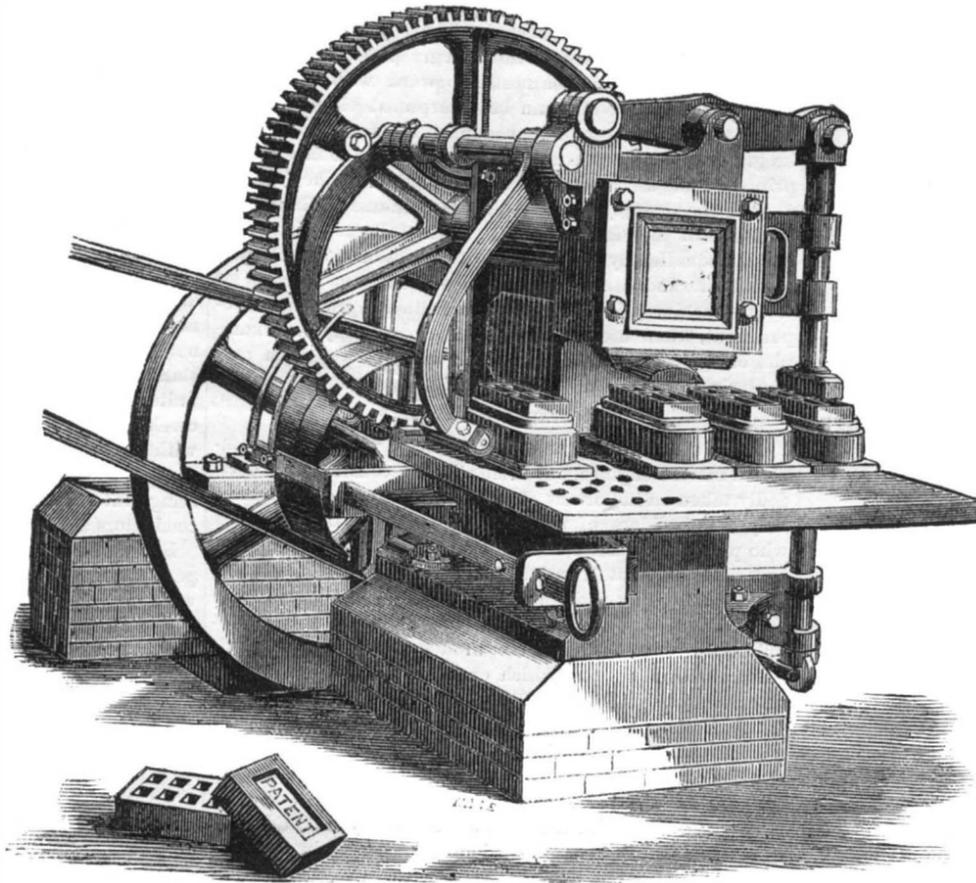
**BRICK COMPRESSING MACHINE.**

are evidently in advance of the Yankees in respect to dining tables.

THE DIAMOND COTTON CHOPPER AND CULTIVATOR.

The invention herewith illustrated, and the distinguishing title of which forms the heading of the present article, is a labor-saving implement, claimed to produce work superior to that done by the hoe in the first working of cotton. With one man and a horse, we are informed, it chops out

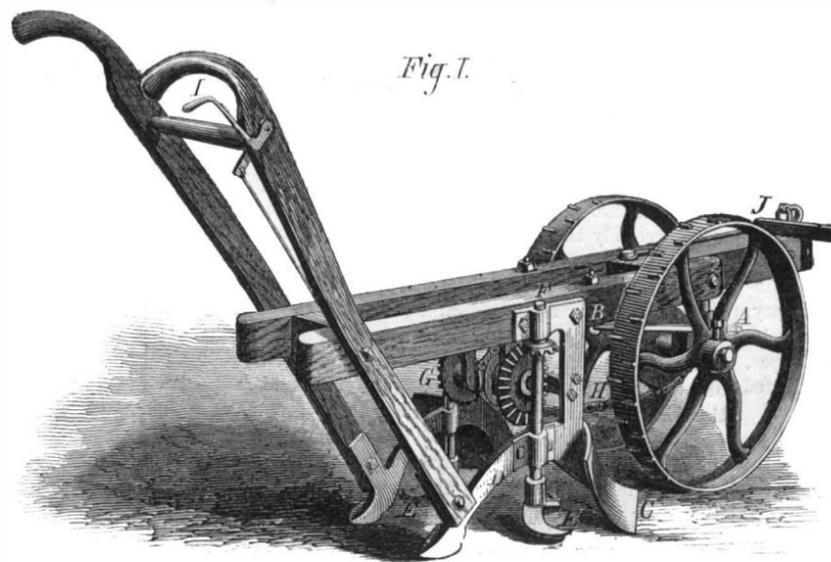
**COTTON CHOPPER AND CULTIVATOR.**

cotton at regular intervals, scrapes and bars it on both sides, and effectually weeds it, at the same time throwing the soil loosely around the young plant for its protection. The hills of cotton are thus left in a diamond shape, about twelve

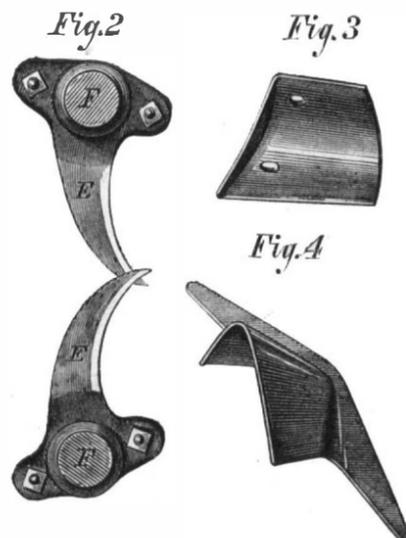

and a fast disk. The latter has a spring-pressed lever pawl on its side, and a notch on its periphery. By means of a pulley on the axle a drive chain, H, is operated. As the cultivator moves forward, the notch of the pulley catches against the down pressed end of the pawl, which is actuated by a lever connecting with the handle, I. The fast disk is thus carried around, and with it the horizontal shaft, so that the choppers are rotated. By pulling the handle, I, the front end of the pawl is lifted out of and above the notch of the pulley, so that the latter revolves loosely on the shaft, thus causing the choppers to be inoperative. The horizontal knives, E, being moved forward at the same time they are rotated, pass through the ground, cutting up the plants and weeding off the grass about a quarter of an inch below the level, leaving hills of plants at regular intervals. The knives may be adjusted so as to cut the spaces shorter or longer by leaving out as many blades as necessary for the purpose. For example, if it be desired to leave a large quantity of cotton on each hill all the blades but one on each sleeve should be removed, as in Fig. 2. To lessen the amount, another knife on each cutter stock is added, so that, by suitable adjustment, the space cut and quantity left for any distance not over 13 inches may be provided for. Above the latter figures, say for 15 or 18 inches, a larger pulley on the shafts and three blades may be required. Where no thinning may be needed, the end of the lever connected with the handle, I, extends over the disk so as to lock the choppers in proper position and leave the plants standing.

The clevis rod, J, is adjustable, so that the horse may walk on one side of the plants without injuring them, while the machine runs immediately over the row.

The device was patented through the Scientific American Patent Agency, July 8, 1873, to J. B. Underwood, but for a year past it has been the subject of careful trials, with, we are informed, complete success. A number of testimonials from farmers in the south bear witness to its efficiency and economy as a labor-saving machine. The patent is owned by the Diamond Cotton Chopper Company, to the Secretary of which, Mr. John W. Hinsdale, No. 2 Hay street, Fayetteville, N. C., letters for further information may be addressed.

To Our Subscribers.

Any of our readers who do not bind their volumes, and have copies of Nos. 4 and 6 of the current volume (July 26 and August 9), will much oblige us by forwarding such numbers to this office.

MINING PICKS.—A number of patents have been secured to present the miner with a pick with shifting points, says the *Mining Journal*, all of more or less merit, but none have come into any extended use; but if such a tool could be manufactured to meet the requirements of the miner for working hard ground, no doubt it would be a saving of time, material, and muscle, as the miner could take equivalent to a dozen picks in his pocket, each point not weighing over six ounces, which, being made of the best cast steel, would do good service.

FRENCH FOUR AXLED ARTICULATED LOCOMOTIVE.

We select from the *Annales des Ponts et Chaussées* the accompanying illustrations of a new locomotive recently invented and constructed by M. Rarchaert. It is a tender engine, weighing, complete, 34 tons, and resting on two American trucks, which are connected with the frame by pivot bolts, so that they follow the bends of the road in a horizontal plane. Measured in a straight line, the extreme wheels of the machine are separated, axis from axis, a distance of 13.1 feet; and the space between wheels of the same truck is 3.9 feet. These dimensions reduce to the ratio of about 10 to 3 the rectilinear length of the apparatus which measures, so to speak, its stiffness; and the minimum radius of curves around which the machine travels freely, is found to be below 96 feet.

The wheels are 3.5 feet in diameter. The maximum speed developed is thirty miles per hour, and the tractile force is estimated at 4.17 tons. The transmission of motion from cylinders to driving wheels constitutes the essential feature of the device. Instead of directly attaching the piston rods, E, to cranks on one of the motor axles, and then transmitting its rotation to the others, the former are caused to act upon a false axle, A, hung in the center of the frame longitudinally, which always retains the same position in relation to the cylinders. The extremities of this false axle carry

cranks, F, to which the piston rods connect, and, beyond these, arms set at right angles, which work the valve rods. The middle portion of the axle is made in the form of an elbow similar in shape to the working axles, B C, to which it imparts motion by the arms, A B and A C. The latter, as the false axle is situated some inches above the center of the driving wheels, form in combination a triangular rod. The advantage of this arrangement is that the false axle has a double purchase on either of the driving axles, that is, directly by means of the straight rods which connect it with each, and indirectly by the rod which actuates one axle, transmitting its motion to the other through the medium of the connection between the two, the lower arm, which, in the upper figure, forms the base of the triangular attachment. A moment's thought will show that there is in this mechanism practically no dead center.

In order to insure the transmission of power in spite of the play of the trucks around their pivot bolts, spherical bearings are arranged for the connecting rods upon the axles, so that the latter conform readily to the angular deviations due to the passage of curves. In fact, the bending of the machine can produce no effect upon the proper application of the power, because the transmitting mechanism is concentrated in a central position, where the length of the parts undergo no sensible alteration. Ordinary coupling rods, G

and H, connect the wheels of each truck. K K are the pivot bolts and L M, longitudinal and cross pieces of the frame.

Experiments conducted in France with this locomotive have proved it an excellent machine for freight traffic on secondary lines, the construction of which necessitates many sharp curves, thus saving the expense of making extensive cuttings to avoid the latter. The form of the ground can thus be more closely followed and the road built at a considerably decreased cost. The engine is stated to have drawn a train of 16 cars, loaded to a weight of 11 tons each, up a slight grade, at the rate of 13.2 miles per hour.

Mineral Oils for Gas.

Within the last 10 or 15 years, many patents have been taken out for processes or apparatus for the destructive distillation of mineral oils, but up to the present time no process has been sufficiently successful as to secure for itself any general recognition. In Germany and the United States, some of the attempts made to use crude petroleum have met with comparative success. The one which the author believes to be the best is the invention of a German chemist, Dr. Herch. The apparatus consists of a circular retort set in the usual manner. The retort is fitted with a mouth piece and lid at each end. The front mouth piece is connected to a large cylindrical chamber or receiver by a

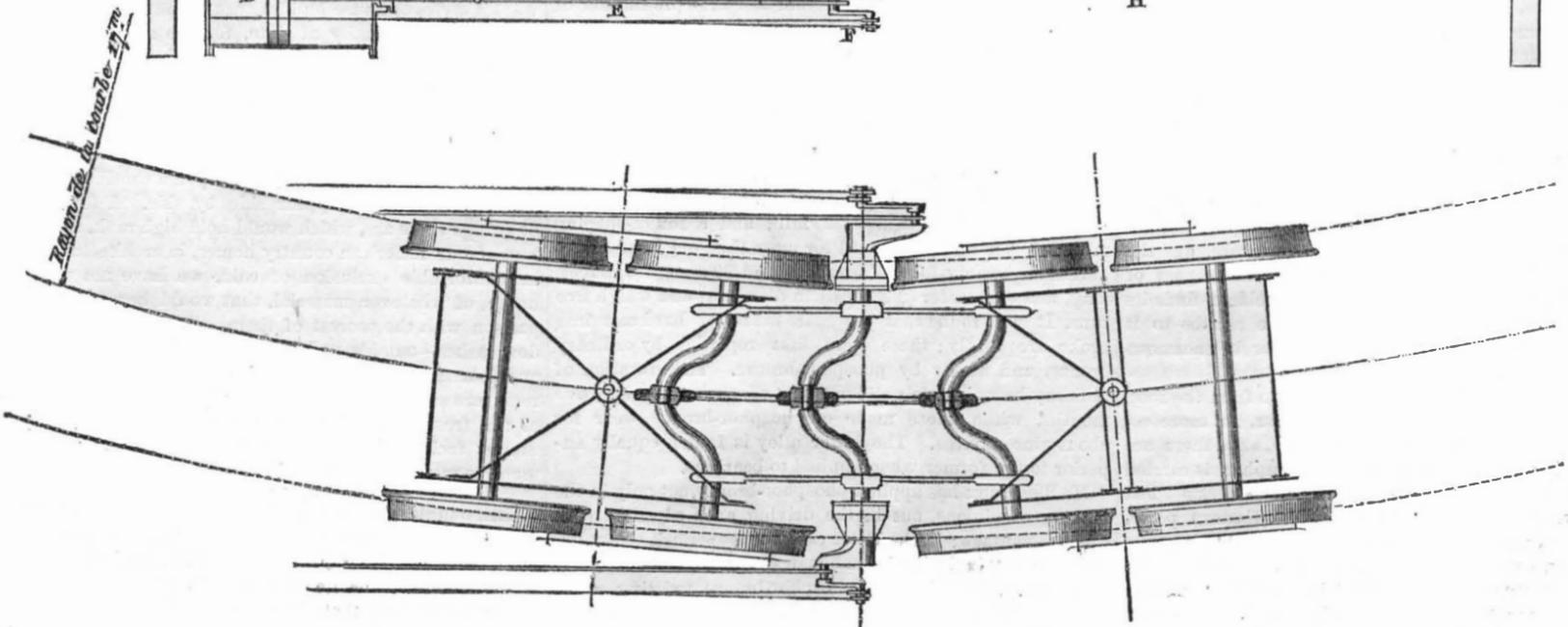
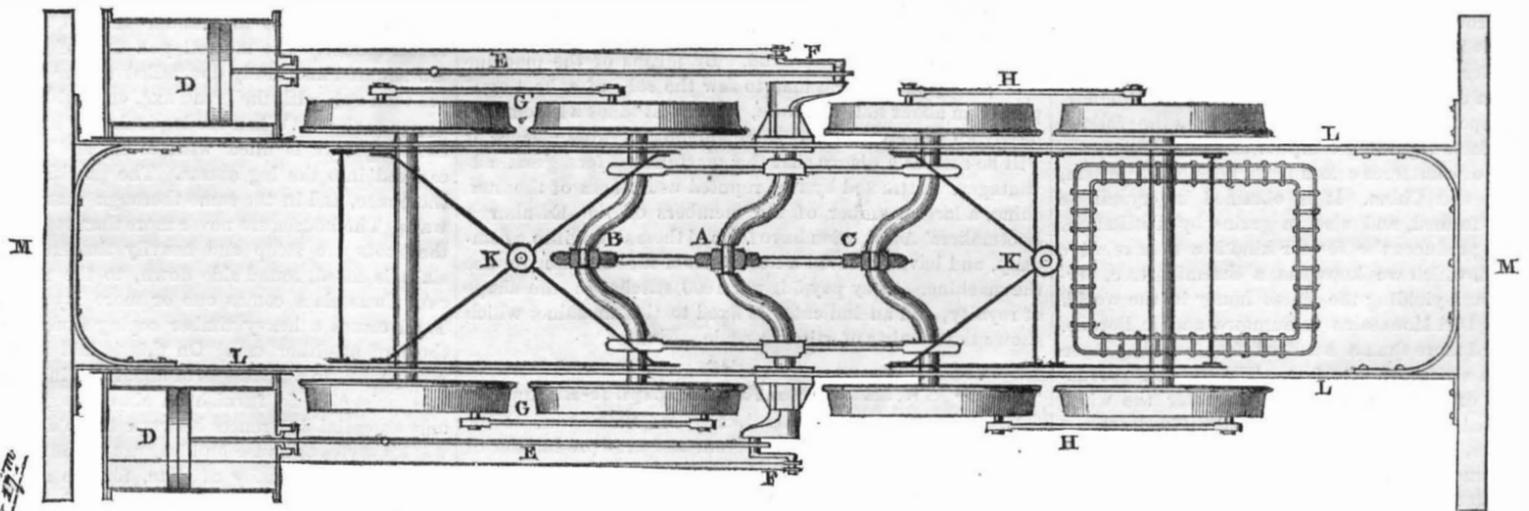
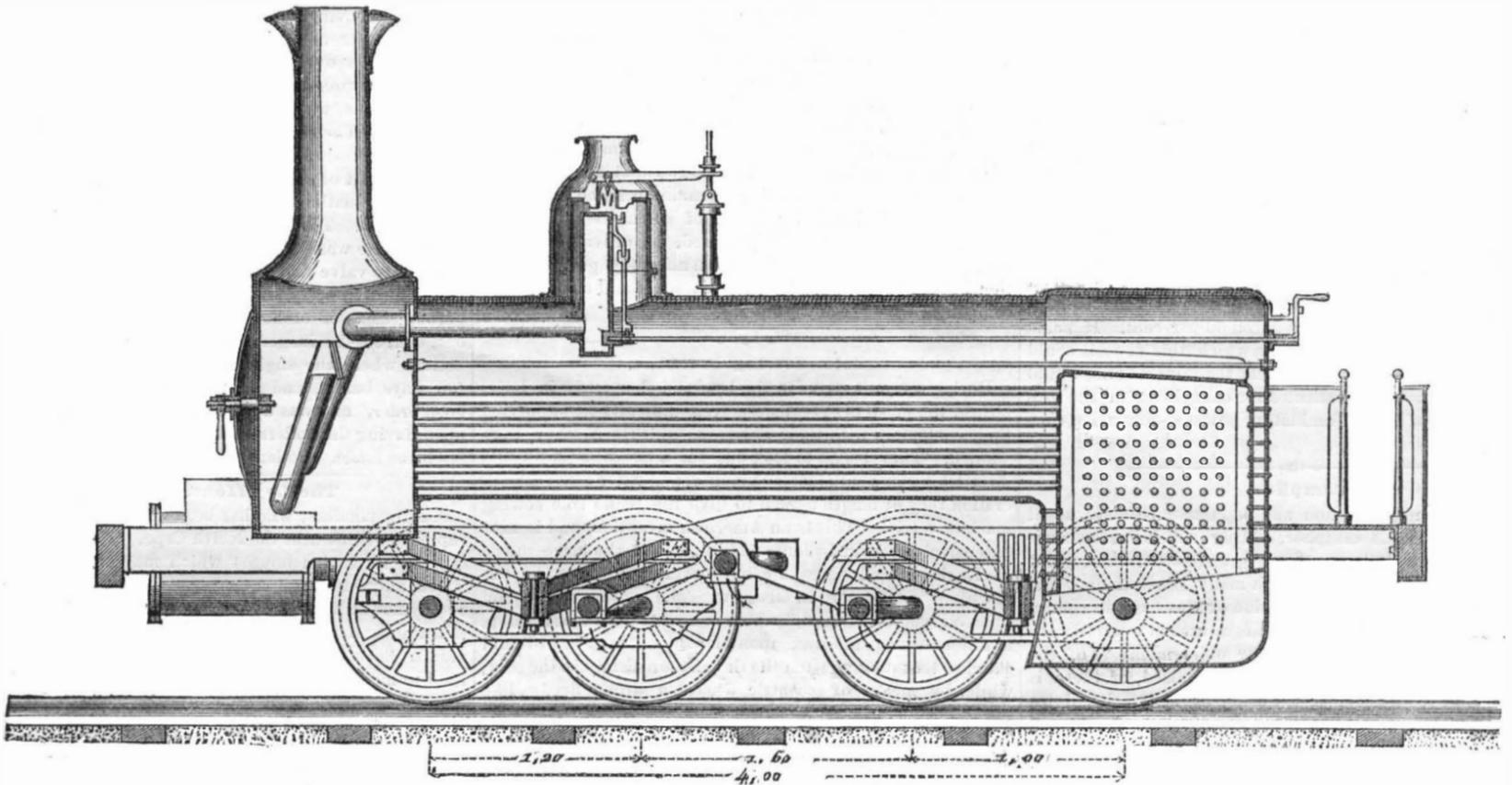

FRENCH FOUR AXLED ARTICULATED LOCOMOTIVE.

taper pipe, which is substituted for the ordinary ascension pipe. At the back of the retort is placed a small cylindrical vessel or chamber fitted with a cover and stuffing box. In the interior of the chamber a weighted piston or plunger is placed, the rod of which passes through the stuffing box. To the upper end of this rod a cord is fastened, which passes over a series of compound pulleys, the end being connected with a train of clock work machinery. From the bottom of the box or chamber in which the piston is placed, a small tube or pipe is connected with the lid at the back of the retort, and thence a small taper tube projects into the interior of the retort. The process of manufacturing the gas is as follows: The chamber or cylinder in which the plunger is placed is filled with the petroleum or mineral oil until the plunger has risen to the top. The cord is then coiled over the pulleys, and the end attached to the clock work. As soon as the retort is sufficiently hot, the pendulum of the clock is set in motion, and the cord is gradually uncoiled. This liberates the plunger or piston, and thus the liquid in the cylinder is forced through the small connecting pipe and taper tube into the retort, where it is distributed in a very thin sheet over the heated surface. A considerable quantity of the vapor is thus converted into gas, and is conveyed by the large taper pipe into the vertical receiver. Here the gas and vapors are separated by the cooling effect of the receiver, the permanent gas passing to a suitable gas holder; the condensed vapors, in the shape of tar or oil, fall to the bottom of the receiver, and are drawn off and returned to the first cylinder, when a fresh charge of oil is put in. The process is exceedingly ingenious, but the author is not able to say what the result of the experiment has been in a commercial point of view. In the United States, many forms of apparatus have been tried, but most of them have failed on account of the great difficulty of getting rid of the rapid deposition of soot or solid carbon on the surfaces of the retorts, or the materials placed within the retorts to effect decomposition. It is found in practice that a comparatively thin layer of this finely divided carbon materially interferes with the process of decomposition, and the result is that, when an apparatus has been at work for only a short time, it happens that the make of gas is reduced 50 per cent. If some arrangement could be invented by which this deposit could be prevented, there is no doubt that the mineral oils would be found most useful substitutes for cannel coal in the production of gas of high illuminating power.—*Journal of Gas-Lighting.*

Camphor.

Perhaps the most common and popular medicinal agent for household use is camphor, a drug which has been regarded as a cure-all by mothers, grandmothers and great grandmothers down through many generations. The "camphor bottle," holding a solution of the agent in rum or dilute alcohol, is found upon a shelf in almost every dwelling; and if among the younger or older members of the family an ankle is turned, or a limb bruised, or there is head ache, or tooth ache, or ear ache, or belly ache, down comes the camphor bottle, and the suffering member is well dosed. Camphor is a powerful agent, and in moderate doses is capable of doing much mischief. It is a matter of wonder that so few instances of injury result, considering its wide spread, empirical employment.

Camphor is brought to this country in a crude or impure state, and here it is subjected to the process of distillation to render it fit for employment. There are several important refineries in the country, one of which is at Rumney, N. H. A correspondent of *The People* presents the following interesting facts regarding camphor and this refinery:

The camphor of commerce comes from Formosa, Sumatra, Borneo, Japan, and China. It is obtained in crystalline masses already formed, and also in grains by distillation. The tree which produces the former kind is a near relative of our basswood, which we know as a charming tree, perfuming the air and yielding the finest honey in the world. It grows on the Diri Mountains in Sumatra, and in Borneo. It towers upward more than a hundred feet, and has been known to attain a girth of fifty feet. The spirited persuasion of the axe draws from this forest monster the white treasures secreted in the longitudinal fissures in its heart wood, sometimes, though rarely, in a layer as large as a man's arm, but more frequently in small fragments to be carefully extracted by some sharp pointed instrument. It is not an abundant bearer. Twenty pounds is a rare yield for a great tree; ten pounds is a good harvest from one of medium size, and many are felled and split that furnish no camphor. This, however, is not an entire waste, since the wood is easily worked and is never attacked by the voracious myriads of Eastern insects which destroy all other varieties except the teak and calambuco. House and ship timber are made from it, besides many articles of furniture, and the aromatic trunk is extremely valuable to the housekeepers of our colder climate. This kind of camphor seldom finds its way to Europe and America. The Chinese ascribe to it marvellous medicinal properties, and pay for it enormous sums, thereby securing the entire yield.

Common camphor is obtained by distillation from the root, stem, and leaves of certain species of *lauraceae*, but more especially from the *laurus camphora*. Of this, also, there are two varieties. The Chinese or Formosa camphor is carried in junks to Canton and there packed in square chests lined with lead, whence it is sent to the different Eastern ports, where we procure it. It is of a grayish color with a grain like sugar, and usually unattractive in appearance. The Dutch or Japan camphor is prepared in Batavia, is packed in tubs securely matted, is pinkish in hue, and coarser than the Chinese. Both kinds need purification before using.

Camphor is slightly soluble in water, but yields freely to alcohol, acetic acid, ether, and the essential oils. A pretty experiment may be tried with it, which the young people will find amusing. Scatter a few pieces of clean camphor upon pure water, and they will whirl and sail about, keeping up the dance sometimes for hours. Drop among them some greasy matter and the merry little performers will stop on the instant.

An Ice Cutting Ferry Boat.

The Erie railway has completed a new ferry boat, with iron hull, for the ferry from New York to Jersey City. The boat, which was designed by Mr. Theodore Allen, naval engineer, and built by John Roach & Son, of New York, is of the following general dimensions: Length between perpendiculars, 180 feet; length on deck, 193 feet; beam over hull, 36 feet; beam over guards, 64 feet. The hull has been designed to give great stiffness, with unusual strength to resist ice. The longitudinal framing is much heavier than is generally used in iron vessels of this size, and at the ends the plating of the hull is made thicker, and intermediate frames and breast hooks are added, with the intention of rendering it so strong that, even when the full force of the engine is exerted, it will be perfectly safe to drive the vessel into the thickest fields of fresh water ice. For additional safety there is, about twenty-five feet from each end of the vessel, an iron watertight bulk head. The boat is driven by a beam engine of 46 inches diameter of cylinder and 11 feet stroke of piston, driving paddle wheels of 22 feet diameter; the steam is supplied by a boiler of the drop return flue type, the engine is handsomely finished, the engine room neatly painted, and the floor laid with encaustic tiles of neat design. In addition to the usual steam pump for feeding the boilers, there is a large size Woodward steam fire pump, with hose connections in hold, on main deck and hurricane deck. A vertical tubular boiler of sufficient capacity, in which steam can be quickly raised, is provided for use when the boat is not running, thus affording great protection in case of fire, both for the boat itself and also for the company's wharves and property.

Sole Sewing Machine.

During a recent strike in the boot and shoe trade in Edinburgh, the masters experienced great difficulty in supplying their customers with their orders as quickly as they were wanted. They began to look out for a machine that would do stitching in a satisfactory manner, and after some consideration they at length agreed to give the Blake sole sewing machine a trial. This is an American invention, and is now extensively used in London, and in some of the large towns in England; and there are not fewer than seven of the machines in operation in Glasgow. The boot or shoe is laid upon a revolving "horn," which is heated by a small lamp, in order to keep the wax upon the thread in a semi-liquid state, so that it may fasten the thread more firmly in the sole; while, by means of eccentric wheels, a strong needle, like that used in crocheting, is forced through the thickest sole, and brought up again by means of a little lever. The machine is capable of being worked either by steam or by hand power, and can sew 300 pairs of boots in one day, while the work, it is said, is even better done than it can be by hand sewing, inasmuch as the waxed threads are drawn more firmly together than it is possible to draw them by the mere force of the hand. By means of the machine it is quite possible for a man to sew the sole of a boot completely in about half a minute, whereas it takes a shoemaker nearly an hour to do the same amount of work; hence it will be seen at a glance that the machine confers great advantages. Attracted by the reputed usefulness of the machine, a large number of the members of the Edinburgh Bootmakers' Association have formed themselves into a company, and have procured a license from the inventor to use the machine. They pay 5d. per 1000 stitches in the shape of royalty, and an indicator is fixed to the machine, which shows the number of stitches made.—*Iron.*

Gear Wheels and Shafts of Phosphor-Bronze.

M. Gilliaux, of Charleroi, and M. Blondiaux, of the Thy-le-Château Society, have, from the first production of this alloy, employed it in the construction of rolling mills, and the following are the results of three years' experience:

This bronze has been employed for the great bearings of plate and general rolling mills, and for conical gearing in universal rolling mills. The motive power of the steam engine that drives the rolling mills in which it is used is of 170 horse power to 200 horse power, and the speed of the rollers about sixty revolutions per minute; the engine drives a sheet iron mill, a universal mill, and a rough-shaping mill, and is not at a standstill for more than one hour and a half in the twenty-four. The rollers are 1.90 meters (6.23 feet) long, and 0.62 meter (2.03 feet) in diameter, and weigh five tons. It was found that the gears made of hard cast iron broke frequently; these were first replaced by ordinary bronze, and finally by phosphor-bronze. The duration of ordinary bronze wheels did not exceed, on an average, five months, while those made of phosphor-bronze wear for about nine months. The latter alloy is found equally superior to the former when applied to bearings.

M. Blondiaux has applied phosphor-bronze, not only in the making of pinions, but in the driving axes of mills, with great advantage; in the latter case the superiority seeming to depend not in the hardness but in the very great resistance of the alloy, the arbors in phosphor-bronze twisting much less than those made of forged iron, and not being liable to break like those of cast iron.

The Hartford Steam Boiler Inspection and Insurance Company.

The Hartford Steam Boiler Inspection and Insurance Company makes the following report of its inspections in the month of June, 1873:

During the month, 1,131 visits of inspection were made, and 2,084 boilers examined, 1,929 externally and 622 internally; while 220 were tested with hydraulic pressure. The defects discovered were 850, of which 207 were regarded as dangerous. These defects were in detail as follows:

Furnaces in bad condition, 35—4 dangerous. We have often called attention to the fact that manufacturers, in providing themselves with boiler power, do not look beyond present wants. If their business increases and new machinery is added, they instruct their engineer to run at an increased pressure, and the boilers are often forced beyond their safe ability. The severe firing necessary burns and contorts the furnace sheets. This practice furnishes many of the cases designated in these reports as "furnaces out of shape." Abundance of boiler power and slow combustion is true economy. Fractures, 45—19 dangerous. Many of these arise from the same cause as that which occasions furnaces out of shape: too small steam room and heavy firing. Burned plates, 45—7 dangerous; blistered plates, 152—29 dangerous; cases of deposit of sediment, 144—22 dangerous; incrustation and scale, 139—18 dangerous; external corrosion, 53—11 dangerous; internal corrosion, 25—13 dangerous; internal grooving, 15—7 dangerous; water gages defective, 25—9 dangerous; blow-out defective, 11—5 dangerous; safety valves overloaded and in unsafe condition, 27—12 dangerous; pressure gages defective, 117—16 dangerous. By dangerous, we mean unreliable, and consequently unsafe to run by. Their variations were such in some cases that the indicated pressure was so much less than the actual pressure that the limit of safety had been passed. Gages require frequent examination and testing. Boilers without gages, 46—1 dangerous. The latter was dangerous from the fact that the pressure was high, and the engineer depended entirely on the safety valve and "the sound of the steam as it issued from the upper try cock." Deficiency of water, 11—7 dangerous; cases of broken braces and stays, loose braces, pins out, etc., 58—24 dangerous. Some of these were found in boilers where the engineer had made an inspection only a few days before, and he "knew that every thing was in good order," and was a good deal put out because we insisted upon having the boilers cold, so that a thorough inspection might be made. Boilers condemned as unfit for use, 12.

The Log House of Norway.

A correspondent, who has been having a week of uninterrupted sunshine near the North Cape, gives us some description of Norwegian houses which may interest our readers. "You may suppose," he says, "that log houses were born on Plymouth Rock; but I find the most convincing evidence that they existed in Norway centuries, perhaps, before Plymouth Rock was known. A yet more interesting fact—at least to me—is that the fashion has not changed. Improvements there have been in many ways, but the log house of Norway is the most fashionable, perhaps because the most comfortable, house. In regions far removed from timber, and where stone and lime and clay abound, even there the log house obtains universal preference. During my trip up and down this long line of Norwegian coast, I have had many opportunities to examine the old as well as the new constructions. Let me tell you first of the old. The logs are squared and nicely dovetailed at the corners. Grooves are then cut, with the broad axe, on both the under and the upper surface. When the log is finally laid to its place, this double groove is filled with moss, and moss is afterward caulked into the log seams. The partitions are built with the house, and in the same thorough manner as the outside walls. The houses are never more than two stories high, and the roofs are steep and heavily timbered. A covering of slabs is fitted, round side down, to the roof timbers; and over these slabs comes one or more layers of birch bark. Then comes a heavy timber coping along the eaves and up the roof at either end. On this is laid sods of rich earth well packed to a thickness of about six inches, and these, in this moist climate, furnish an abundant grassy finish. The only essential differences between the old and the new Norwegian styles of house building are in the substitution of red tiles, and occasionally of slate, for the sod roofs, and the casing of the timber, which forms the body of the house, with thin boards, for looks' sake.

Within a year the town of Namsos, about one hundred miles north of Drontheim, was almost totally destroyed by fire; and it is now in course of rebuilding. Here, notably, the work of building is going on upon a considerable scale, and the two modes appear side by side. A few finished buildings there are, which would hold high rank, among the best of our American country homes, in architecture; while in comfortable exclusion of cold, we have not a country house, of whatever material, that would bear a rigid comparison with the poorest of them. Double glazing of window sashes—outside and in—the packing of every window and door frame with moss, and a careful papering of every room, are some of the means taken to prevent any circulation of the frosty air. For winter comfort, combined with the utmost facility for every conceivable ornamentation, commend to me the Norwegian log house. B."

THE puddlers in the Phoenixville (Pa.) Iron Works struck for higher wages on the first of April and the company laid not a straw in their way. Now after having lain idle nearly four months, they go to work at their former wages, and only on condition that they have nothing more to do with the Union.

American Asphaltum.

Under this heading, Professor S. T. Peckham, of Buchtel College, Akron, Ohio, communicates to the *American Chemist* an article in which he takes issue with several of the statements previously made by Dr. Newberry on the same subject and in the same periodical. Professor Peckham has already published several papers on this topic, and has personally examined, over a considerable period of time, the bituminous out-crops of Lower California. The latter, he states, may be roughly estimated as covering an area of 75 miles in length by from 5 to 40 miles in width, and they probably contain more asphalt than any surface of equal extent in the western hemisphere, except the Pitch Lake of Trinidad.

Bitumen occurs there of every variety, from green petroleum of the consistence of olive oil to solid asphaltum heavier than water. There are millions of tons of asphalt, some of it pure, but the largest portion contains from one to ninety-nine per cent of all sorts of impurity, chiefly soil, shale, gravel, sand, and organic matter, both animal and vegetable. The maltha passes by imperceptible degrees, from dense oil, through tar, to a mass resembling mortar in consistence and heavier than water. There are thousands of barrels of maltha and a few barrels of petroleum; but there is not a particle of asphalt or any other natural bituminous product in that region, that is a residuum from the evaporation of petroleum.

Maltha, or tar of varying density, has been obtained at from ten to four hundred and sixty feet from the surface—a depth too great to admit of the slightest action of the sun's rays. Nor could the evaporation be due to solfataric action, since, where such action was most apparent, on the south side of the sulphur mountain, were obtained the least dense and most slightly altered petroleum. Without a single exception, every outflow of bituminous material, whether natural or artificial, proved that the change from petroleum to maltha and asphaltum is due to the action of atmospheric oxygen, either direct or transmitted by rain water. The only natural springs of petroleum that I saw or heard of in that region were the Canada Laga and Pico Springs. The first issued from an almost perpendicular cut in strata overlaid by several hundred feet of shale. The second issued from shale that was overlaid by unbroken bands of sandstone and conglomerate, affording ample protection. The tunnels in which petroleum was obtained were invariably driven into the nearly perpendicular face of a cliff or mountain side, into strata that were well protected by hundreds of feet of overlying rock. Tunnels of the same length, driven on strata that were not thus protected, invariably yielded nothing but maltha or oil more or less changed. On the plains northwest of Los Angeles, an artesian boring, that penetrated sandstones interstratified with shale, yielded maltha at a depth of four hundred and sixty feet. Professor Peckham goes on to deny the fact that maltha at the bottom of wells is the result of evaporation, and cites various facts and testimony in support of his position. As regards the Canada asphalt beds, he maintains similar views and does not believe that the origin of albertite, grahamite, or any such substance, has the remotest connection with petroleum of any description, or that these asphalts bear any relation to still residues. He continues that he never saw a residue of Pennsylvania petroleum that was not coked that did not contain paraffin, or a particle of California petroleum, maltha or asphalt, or any substance distilled from them, that did contain a trace of paraffin or any other solid matter.

The distillates from California bitumens, of the same specific gravity as those from Pennsylvania oils, have a different color and odor, and cannot be burned in the same lamps without smoking. They evidently contain a larger proportion of carbon. It is needless to add that none of these substances derived from petroleum bear any relation to coal tar residue.

It is important that the relations of these substances be properly understood, and that the language of science be cleared of the obscurity in which, from the time of Boerhaave to the present, this subject has been involved. We might just as well now as ever, concludes the writer, deny the existence of maltha or mineral tar, as distinguished from petroleum, as talk about the "petroleum springs" of California and the "far west." Does it really add anything to the value of a tar spring to call it a petroleum spring, or to a hill side smeared with maltha to call it a "petroleum cascade?" Just as well call a barrel of tar "spirits of turpentine," and insist that a purchaser should take either at random.

Waterproof Paint for Canvas.

The following is a cheap and simple process for coating canvas for wagon tops, tents, awnings, etc. It renders it impermeable to moisture, without making it stiff and liable to break. Soft soap is to be dissolved in hot water, and a solution of sulphate of iron added. The sulphuric acid combines with the potash of the soap, and the oxide of iron is precipitated with the fatty acid as insoluble iron soap. This is washed and dried, and mixed with linseed oil. The addition of dissolved india rubber to the oil improves the paint.

The Meteoric Shower of August 10.

We have reports from observers at Mont Clair, N. J., who noted fourteen meteors, seen within forty-five minutes, between the hours of eight and nine in the evening of August 10. General direction of movement, from N. E. to S. W.

A correspondent at Keyport, N. J., reports the observance of brilliant meteors there on the evening of the 10th.

A correspondent at Milwaukee, Wis., reports quite a number of meteors seen on the 10th. But the largest number were seen on the evening of the 9th.

Inventions Patented in England by Americans.

(Compiled from the Commissioners of Patents' Journal.)
From July 22 to July 31, 1873, inclusive.

BELL PIANOFORTE.—U. C. Hill, New York city.
BOILER AND GOVERNOR.—G. Merrill, New York city.
DOOR BELL.—J. B. Sargent, New Haven, Conn.
DRYING KILN, ETC.—J. A. Locke, New York city.
ENGINE AND PISTON.—G. Merrill, New York city.
FILTERING PROCESS.—T. R. Sinclair, New York city.
MECHANICAL TOY.—V. A. P. La Grove (of Brooklyn, N.Y.), London, Eng.
PACKING WATER COLORS.—C. T. Reynolds & Co., New York city.
PURIFYING GAS.—W. H. St. John, New York city.
SEWING MACHINE ATTACHMENT.—H. M. Hall, Philadelphia, Pa.
SILK SPREADING MACHINE.—J. Sault, South Manchester, Conn.

Recent American and Foreign Patents.**Improved Sawing Machine.**

Harry M. Stow, Milan, O.—The object of this invention is so to improve the construction of the saw guide that the stroke of the saw may be rapidly changed and adapted to the requirements of the cutting operations. The increase and decrease of the stroke is produced by simple means, and easily regulated. The invention consists of lever connections, acting on the front and pitman end of the saw shaft, to be operated simultaneously or separately, as desired.

Improved Music Leaf Turner.

George W. White, Brooklyn, N. Y.—This invention consists in a series of leaf turning arms arranged loosely on a pivot at the top of a support adapted to rest on the book rack of a musical instrument. On said pivot is a wheel with an arm which acts against all the leaf turning arms on one side and swings them around to the side from which the leaves are to be turned, when a lever at the bottom of the support, connected with a segment gearing with said wheel, is pressed down by the player. There is another wheel on said pivot for throwing the arms in the other direction one at a time, to turn the leaves, when a similar lever at the bottom of the stand, connected with said wheel by a toothed segment, is pressed down. This last wheel is thrown back by a spring, and the first one is turned back by the last when it throws the first arm. The invention also comprises a spring clip for the arms to clip the leaves and hold them, so as not to slip out when the arms swing, which is so constructed that it can be opened readily for engaging the leaves by pinching it between the thumb and finger.

Improved Cake Pan.

John B. Firth, Brooklyn, N. Y.—This invention consists of cake pans on frames, in which the pans shall be secured in place firmly and neatly, and in such a way that they can be conveniently cleaned and washed, and that they will not be liable to become loose.

Improved Portable Fence.

Theodore L. Wiswell, Olathe, Kansas, assignor to Ray Amasa Wiswell, of same place.—The object of this invention is to improve what is known as the "worm fence." Triangular shaped posts govern the position of the panels and the shape of the fence. These posts do not extend into the ground, but the rails are fastened to them by a single bolt or pin at each end, so that they will turn on the bolts or pins, and thus give the fence a degree of flexibility for crossing uneven ground. The panels are connected together with iron staples. Two of these staples are usually employed, one near the top and one near the bottom. Keys are driven through them, by taking out which the fence may be taken down, removed, or packed away.

Improved Reciprocating Winner.

Henry Keller, Sauk Center, Minn.—The lower grading screen is made in two parts. The upper sections are elevated above the planes of the lower ones, so that the wind from the fan can act with much better effect on the grain, both for separating the oats and other light matters at the upper end of the upper sections, and the screenings at the point where they are separated. The upper section of the lower screen is made shorter than the upper section of the upper screen, to give the oats a better chance of dropping down. The lower section of the lower grading screen does not extend quite as low down as the end of the upper screen does, and delivers its grain between the partitions of the grain box and the side of the screen box. The upper screen delivers its grain on the other side of partition which separates the grain box from the fan chamber.

Improved Evener for Thread.

John B. Meldrum, Paterson, N. J., assignor to the Barbour Flax Spinning Company, of same place.—This invention is an improvement in the class of thread eveners formed of vertical jaws adjustable toward or from each other; and the improvement consists in adapting the jaws to be adjusted independently and also simultaneously, as occasion may require.

Improved Corn Planter.

Edward Parmentier, Clinton, Ill.—The drive wheels revolve upon and carry the axle with them in their revolution by clutches held up by springs and operated by levers. By suitable mechanism, the said levers may be struck and operated to withdraw the clutches from the wheels by the rear end of the tongue when the furrowing and dropping devices are raised from the ground. To the lower ends of the conductor spouts are rigidly attached the openers, the rear parts of which are widened and have an opening formed in them directly beneath the discharge opening of the spouts, so that the seeds may be deposited in the bottom of the furrow before said furrow becomes partially filled by the soil falling inward from its sides. The forward part of the lower edge of the openers are inclined or rounded upward to enable it to pass through the soil and over obstructions more readily. The openers enter slots in the shoes, which are drawn along the surface of the ground, pushing back obstructions and smoothing the said surface. The openers may be adjusted to project below said drags according as the seed is to be deposited at a greater or less depth in the ground. To the outer sides of the drive wheel are attached rings, which are grooved to receive flanges formed upon bars, the centers of which ride upon the outer ends of the journals of the axle, and which are made of such a length that their ends may come in contact with and mark the surface of the ground as the said wheels revolve. The markers are connected with the wheels, so as to be carried around by and with the said wheels in their revolution by set screws, so that the bars may be conveniently adjusted to mark the ground directly opposite the hills.

Improved Horse Hay Rake.

Watson C. Martindale, Philadelphia, Pa.—This invention consists in an improved horse hay rake, which is so constructed that the teeth may be raised to discharge the hay by the advance of the machine, and may be disengaged automatically and allowed to drop back to the ground when the hay has been discharged. By suitable construction, as the machine is drawn forward, a rod will be revolved. When a sufficient amount of hay has been collected, the lever pawl is thrown into gear with the ratchet wheel. This stops the revolution of the rod so that as the machine continues to advance the rod and axle are carried forward, which raises the teeth and discharges the hay. As the rod and axle are carried forward the projecting end of the lever pawl strikes an inclined arm attached to the foot board, which disengages the pawl from the ratchet wheel and allows the teeth to drop back to the ground, ready to again collect the hay.

Improved Cane Stripper.

Robert C. James, Denison, Texas.—This invention is an improvement in cane strippers of the class in which a pair of drawing rolls are arranged in combination with a fixed and movable spring stripping blade. A single stack is passed through each hole in the table to the rollers below by the attendant, so as to be seized by them and pulled through while the stripping blades are bearing against them on one side and pressing them against the hole on the other, which strips off the leaves and other substances suitable for fodder, and prevents them from going into the kettle, and saves a large amount of skimming.

Improved Brake for Railroad Cars.

James Temple, Mooresburg, Pa.—This invention relates to a novel and effective brake for railroad cars, designed to operate to a more advantageous degree than brakes of the description upon which the improvements are based. The invention consists in the employment of a longitudinal bar carrying at or near its ends arc-shaped brake shoes.

Improved Heel Trimming Machine.

Elisha U. Jones, Woodhaven, N. Y.—This invention has for its object to furnish an improved machine for trimming shoe heels. The crank, by means of which motion is given to the machine, is attached to a shaft which revolves in bearings in the frame. To the shaft is attached a small bevel gear wheel, which engages with the large bevel wheel attached to a vertical shaft. To the upper end of the latter is attached a wheel, the edge of which is made in the form of a double cam, to allow the arm that carries the knife to move inward at the proper times. A screw rod limits the movement of the knife and serves as a guiderod to hold the coiled spring by which the knife is held out to its work. The knife is made with a finger, which projects in front of its cutting edge and rests against the edge of the guide, which rests upon the top of the cam plate and is secured detachably to the upper end of the vertical shaft. The guide is made of the exact form to be given to the heel, and must be changed with every change in the form or size of the heel. A short hook rod on the arm enters a groove formed in the under side of the cam wheel, which groove is so formed as to cause the knife to move forward quickly to cut the elongated sides of the heel, and slowly while cutting the short curve of the rear part of the heel. A clutch grasps the top of the last directly over the heel, so as to hold the shoe heel firmly upon the guide plate while being turned and trimmed. In using the machine, the shoe is placed in position, and the crank is operated to give it a half revolution; the shoe is then removed and the revolution completed to bring the machine into position to receive another shoe.

Improved Water Wheel.

Oliver J. Bollinger, York, Pa.—This invention relates to that class of water wheels with which hinged or pivoted gates are used; and has for its object to remedy the difficulties arising from the manner in which the studs are fitted and secured to the gates. The invention consists in the lug of a pivoted or hinged gate of a water wheel, made with a vertical hole to receive the stud, and a transverse hole to receive the wedge key; and in the cross head stud, made with a transverse notch to receive the key for securing it detachably to the lug of the pivoted or hinged gate of the water wheel.

Improved Method of Restoring Tinned Sheet Iron.

William E. Brockway, New York city, assignor to William L. Brockway, of same place.—The vast number of tin cans used for preserving articles are considered worthless when emptied of their contents, and are thrown away by the million; but the iron which is tinned and used for these cans is of the first quality, or much tougher than ordinary sheet iron, and much better adapted for many purposes when restored, especially for binding trunks, and for many similar purposes where pieces of large superficial measurement are not required. The object is to utilize these cans now thrown to waste; and this invention consists in the process of restoring the iron to its original state, but in small sheets, and thereby utilizing it. Tin melts at about 450°, but will not entirely leave the iron until subjected to a higher temperature. The iron is therefore subjected to a temperature of about 1,000°, or to a cherry red. This cleans off the tin and anneals the iron, rendering the latter very pliable, and adapts it for many purposes where toughness and pliability are essential. When the iron is taken from the oven the pieces are passed between rollers, which press upon it just sufficient to straighten it and prepare it for market.

Improved Rock Drill.

George E. Nutting and Joseph C. Githens, New York city, assignors to A. C. Rand of same place.—This invention has for its object to furnish an improved steam rock drill, which shall be so constructed that the valve may be shifted at the proper time to cut off the steam, and at the same time admit the steam in front of the piston, so that it may cushion itself upon steam and diminish the jar or shock, and in which the piston may turn, and thus turn the drill as it makes its up stroke. To the end parts of the valve stem are rigidly attached two disks, at a distance apart equal to the distance required for the throw of the valve, and an additional thirty-second of an inch, more or less. Upon the stem upon each side of the valve are placed pistons of such a length as to give the valve and two pistons a play of about a thirty-second of an inch upon the stem, between the disks. The diameter of the disks is made enough less than the diameter of the end parts of the valve chest to allow the steam to pass the said disks freely. By suitable construction, as the piston comes to the upper part of the cylinder, the lower port is uncovered and the steam passes through it into the lower end of the steam chest, below the lower disk. As the steam enters the lower part of the steam chest it forces the disks, pistons, valve, and valve stem upward until the upper disk strikes its stop and stops the forward movement of the stem and disks. The steam now passes around the edge of the lower disk and forces the pistons and valve upward until stopped by the upper disk. This movement allows the steam in the end part of the steam chest to exhaust through the exhaust. The exhausts are so arranged as not to be fully closed until the valve pistons and disks have nearly completed their stroke. By this construction the valve and its attachments and the piston will always move in the same direction, which lessens the jar, and consequently the wear, of the mechanism. A simple friction device is so arranged as to rotate the piston as it rises, but to allow said piston to descend without turning. The lower end of the piston rod is made hollow to receive the drill bit, and is slotted longitudinally to divide it into three or more parts so that the drill bit may be securely held and may be conveniently detached when desired.

Improved Stitching Gage for the Blind.

William H. Richardson, Fort Smith, Ark.—This invention consists of an improved stitching gage for the blind, formed of bottom, front, and rear plates. In the upper part of the front plate is formed a horizontal slot through which the stitching is done. The upper edge of the rear plate is about upon a level with the lower edge of the slot in the front plate, and in the said plate are formed two vertical slots to receive the buckle bars to enable the work to be held firmly against the slot in the front plate. In the center of the bottom plate is a hand nut, through the screw hole of which passes a screw the upper end of which is rigidly attached to the platform, upon the lower edge of which the work rests when stitching straight work. The platform slides up and down along the inner side of the front plate, and is kept in place by grooved flanges. To the outer side of the front plate is attached a horizontal bar to prevent the gage from setting too deep in the jaws of the stitching horse. To the outer side of the front plate is detachably attached a ratchet bar which has as many teeth to the inch as the work should have stitches to the inch. Upon the outer side of a slide, where the awl is to be inserted, is formed an inclined projection, against which the tapering forward end of the ferrule of the awl strikes, and thus pushes the slide forward one tooth each time the awl is inserted. In using the gage, when the work has been stitched the length of the slot, the work is moved forward until the awl strikes the other end of the slot, the slide is moved up to it, and the gage is again ready for work.

Improved Cotton Planter.

Robert E. Bowen, George's Creek, S. C.—This invention relates to the construction of cotton planters with a view to enable them to be easily and cheaply manufactured, while their efficiency is maintained or increased. It consists in improving the ordinary shaking hoppers, which have arms moved up and down by side studs on a wheel, so that the seeding operation may be easily and conveniently stopped and resumed.

Flame Extinguisher for Lamps.

William D. Lindsley, Wathena, Kansas.—This invention consists in making a very durable and compact joint of both spring and extinguisher with the movable arm of the latter by bending and riveting the end of the arm.

Improved Box Scraper.

Charles Ellis, George W. Ellis, John D. Ellis, Philadelphia, Pa.—This invention consists in a certain construction of stock and scraper, and means of attaching the same to each other, and to the handles, whereby a convenient and handy tool is produced.

Improved Windmill.

Samuel Shannon, Shellsburg, Iowa.—This invention relates to improve ment in the class of windmills having vanes so pivoted that the force of the wind tends to turn them around it; and consists of a double crank shaft and a reciprocating sleeve on the post, on which the wheel frame is pivoted and around which it swings, so contrived that a connection is made with a pump rod, or two or more, if desired, on the side of the post, and the rod or rods worked thereby without hindrance to the turning of the wheel frame and without any cramping or side draft.

Business and Personal.

The Charge for Insertion under this head is \$1 a Line.

The New Elastic Truss presses uniformly all around the body, and holds the Rupture easy, night and day, till cured. Sold cheap by the Elastic Truss Co., 683 Broadway, New York.

For Sale—A Walker Bros. Percussion Mill for pulverizing hard substances. Thos. Waring & Bro., Colera, Cecil Co., Md.

For Sale—3 Pat's at less than half their value, two for Impr'ts in advertising Lanterns, one for Impr'ts in Envelopes, by S. Kuh, Jefferson, Iowa.

Gasoline or Stove Oil Vapor Burners—Manufacturers, send circular to J. R., Box 183, Middletown, Md.

A Chemist wants a situation as teacher, lecturer or analyst. Address J. S., New York Post Office.

For Sale—A Thomson's Patent Road Steamer at half cost. Enclose stamp to James C. Smith, Fayetteville, N. C.

Liberal cash price or share in profits for any marketable article that will sell. Cash advanced for patent if not patented. Address Jarvis & Co., Broadway, N. Y.

To sufferers from batteries that get out of order on Burglar Alarms, etc., the Leclanche Battery Co., 40 West 18th st., New York, guarantee these batteries to last one year without any attention.

New Motion—One Shaft rotating, rotates in opposite direction another shaft at any distance. Only one connecting bar used. Rights for Sale. W. H. Benson, Waynesboro', Virginia.

Bolt Makers, send for descriptive cuts of Abbe's Bolt Machine, to S. C. Forsyth & Co., Manchester, N. H.

Mills for Flour, Feed, Paint, Ink, Drugs, Spices and all other purposes. Ross Bros., Williamsburgh, N. Y.

Hydraulic Presses and Jacks, new and second hand. E. Lyon, 470 Grand Street, New York.

Sure cure for Slipping Belts—Sutton's patent Pulley Cover is warranted to do double the work before the belt will slip. See Sect. Am. June 21st, 1873, Page 889. Circulars free. J. W. Sutton, 95 Liberty St., N. Y.

Catalogue on Transmission of Power by Wire Rope. T. R. Bailey & Vail.

The Olmsted Oiler is the best; it is self-righting, strong and cheap. All Hardware and Tin Houses have it.

Mining, Wrecking, Pumping, Drainage, or Irrigating Machinery, for sale or rent. See advertisement, Andrew's Patent, inside page.

Buy Gear's Improved Balanced Jig Saw, Boston, Mass.

Inventors who desire to have their inventions and patents introduced and represented in Europe by a gentleman of experience and integrity, should address K., Box 2979, New York Post Office.

State Rights for Sale, or work on royalty. A valuable Patent on Boiler Feeders. Must be seen to be appreciated. Address E. Brockway, Haverstraw, N. Y.

For Sale—New Patent for Refrigerator and Beer Cooler, etc., combined. Enquire of or address G. Nuss, 55 1st Avenue, New York City.

Key Seat Cutting Machine. T. R. Bailey & Vail.

Buy Boulton's Patent Moulder for all kinds of Edge and Surface Moulding on Wood. B. C. M. Co., Battle Creek, Mich.

Portable Hoisting and Pumping Engines—Ames Portable Engines—Saw Mills, Edgers, Burr Mills, Climax Turbine, Vertical and Horizontal Engines and Boilers; all with valuable improvements. Hampson, Whitehill & Co., Newburgh Steam Engine Works, Depot 38 Cortlandt Street, New York.

You can get Improved Machinery from Gear, Boston, Mass.

The Cornell University, Ithaca, N. Y., offers liberal and practical courses for agriculturists, architects, civil engineers, master mechanics, mechanical engineers, agricultural and manufacturing chemists, printers, veterinary surgeons, etc., with laboratories, draughting rooms, farms and work shops. In agriculture and mechanic arts, various courses are provided to meet wants of all students; also general courses in arts, literature and science preparatory to the other professions. Over five hundred free scholarships. Next year begins Sept. 8. For Registers, with full information, address as above.

Lathes, Planers, Drills, Milling and Index Machines. Geo. S. Lincoln & Co., Hartford, Conn.

Scale in Steam Boilers—How to Remove and Prevent It. Address Geo. W. Lord, Philadelphia, Pa.

Williamson's Road Steamer and Steam Plow, with rubber Tires. Address D. D. Williamson, 32 Broadway, New York, or Box 1809.

Cabinet Makers' Machinery. T. R. Bailey & Vail.

Root's Wrought Iron Sectional Safety Boiler, 1,000 in use. Address Root Steam Engine Co., 3d Avenue and 28th Street, New York.

I want the sole or part agency of Can. of a few Specialties that are protected by patent or cheap manufacture. Address, for two months, J. F. Cass, L'Original, Ont.

Inventors or parties having specialties for sale, which they would like introduced and represented in cities of Pittsburgh and Allegheny, address C. Runyan, Box 598, Pittsburgh, Pa.

Belting—Best Philadelphia Oak Tanned. C. W. Arny, 301 and 303 Cherry Street, Philadelphia, Pa.

For Solid Emery Wheels and Machinery, send to the Union Stone Co., Boston, Mass., for circular.

All Fruit-can Tools, Ferracute, Bridgeton, N. J.

For best Presses, Dies and Fruit Can Tools Bliss & Williams, cor. of Plymouth & Jay, Brooklyn, N. Y.

To Manufacturers—Built expressly to rent, New Brick Building, 60x80 ft., 3 stories high, divided by fire proof walls, with ample water power. Room and power in quantities to suit. Address Industrial Mfg Company, Rock Falls, Whiteside Co., Ill.

Stave & Shingle Machinery. T. R. Bailey & Vail.

Five different sizes of Gatling Guns are now manufactured at Colt's Armory, Hartford, Conn. The larger sizes have a range of over two miles. These arms are indispensable in modern warfare.

Machinists—Price List of small Tools free; Gear Wheels for Models, Price List free; Chucks and Drills, Price List free. Goodnow & Wightman, 28 Cornhill, Boston, Mass.

For Solid Wrought-iron Beams, etc., see advertisement. Address Union Iron Mills, Pittsburgh, Pa., for lithograph, etc.

Bookkeepers should try the Olmsted Patent Bill File and Letter Clip. They are admirable for all papers. Save their cost in one day's business. Sold by all Stationers. J. H. White, Newark, N. J., Sole Manufacturer.

Gauge Lathe for Cabinet and all kinds of handles. Shaping Machine for Woodworking. T. R. Bailey & Vail, Lockport, N. Y.

Covering for Boilers and Pipes. The most economical and durable article in use. Too first prize at American Institute Fair. Van Tuyl Manufacturing Company, 528 Water Street, New York.

Nickel and its Uses for Plating, with general description. Price 50c. a copy, mailed free, by L. & J. W. Feuchtwanger, 55 Cedar St., New York.

Silicate of Soda and Potash—All grades, in liquid, jelly, and dry state, for sale in quantities to suit, by L. & J. W. Feuchtwanger, 55 Cedar St., New York.

Parties desiring Steam Machinery for quarrying stone, address Steam Stone Cutter Co., Rutland, Vt.

Boring Machine for Pulleys—no limit to capacity. T. R. Bailey & Vail, Lockport, N. Y.

Brown's Coalyard Quarry & Contractors' Apparatus for hoisting and conveying material by iron cable, W. D. Andrews & Bro., 414 Water St., N. Y.

The Best Smutter and Separator Combined in America. Address M. Deal & Co., Bucyrus, Ohio.

Damper Regulators and Gate Cocks—For the best, address Murrill & Keizer, Baltimore, Md.

Steam Fire Engines, R. J. Gould, Newark, N. J.

Peck's Patent Drop Press. For circulars, address Milo, Peck & Co., New Haven, Conn.

Notes & Queries

J. B. F. asks: What is the best process of cleaning and tinning old copper saucers?

J. W. S. asks: Is there any substance which, when enclosed in a glass tube or bottle, will give a continuous light, brighter than phosphorus?

T. E. asks: How can I prepare gelatin for heliotype printing? What are the materials and proportions for making the inking rollers?

A. M. asks: How is the solution used in electroplating with tin, described on page 71 of the present volume, prepared?

W. A. B. asks: How can I restore ivory to its natural color? What is the composition of the cement with which knives are fastened in the handles?

H. R. E. asks: Can articles be coated with steel by an electrolytic battery, and how?

P. L. B. asks: What will keep cherry boards from warping?

G. P. asks: 1. How can I make oiled silk? 2. How can I make a waterproof varnish for muslin bags, which will not crack when the bags are folded up?

B. I. L. asks: 1. Of what substance are Mr. Rogers' groups of statuary composed? 2. Is there a book which describes the tools and *modus operandi* used in making such statuary?

E. says: I have several hundred horse power running to waste three miles distant from a manufactory where I require thirty or forty horse power. Can you advise me how it is practicable to transmit the water power over that three miles to drive the manufactory?

E. asks: Is there any value in a miner's compass? "I bought one, and when new, the north pole was readily influenced by the presence of metallic iron. It was sent 300 miles by rail, and lost its attraction for metallic iron; but when carried into a shaft of limonite ore, the south end points down and the north end up, at an angle of about 70°. Outside the mine, the south pole dips about 10°, and at other places 20°. Why does the south pole dip instead of the north pole? Is the needle of any practical value in prospecting? What are the difficulties in using it, and how are they to be guarded against?"

ANSWERS TO CORRESPONDENTS

A. F. A. says: Please give a rule for calculating the power of a tube boiler. The fire is under the boiler and comes through the tubes. Answer: Calculating the heating surface in square feet, and dividing by 15, will give you the horse power, approximately.

J. W. asks: What are the component parts of nitro-glycerin, and the relative amounts by weight of each ingredient? Answer: Into a mixture of four and two thirds pounds of concentrated sulphuric acid and two and one third pounds of concentrated nitric acid, pour one pound of glycerin if you have the terrible explosive agent, nitro-glycerin.

Z. M. P. K. asks: What cheap chemical preparation will dissolve and clean earthen pipe sewers from a tough sediment adhering thereto, supposed to be caused by grease and soap suds from washing dishes, etc.? Answer: Try washing with milk of lime, or strong lime water.

W. K. M. asks if apple pomace distributed round a well of water would cause an engine which uses the water to rust or cut. The engine is sometimes found to be quite rusty in the morning. Answer: We do not think the result you speak of is produced by apple pomace, but more probably by dampness in the atmosphere.

W. P. B. asks: What is the comparative efficiency, for draft, of brick and iron chimneys, also how much difference will the form, square or round, make? What is the rule for size and height of chimneys, computed from the boiler? Can you mention any cheap work giving reliable information on kindred subjects? Answer: A round chimney of brick is probably the best. No. 1 of Van Nostrand's "Scientific Series" will probably give you the desired information.

G. T. L. asks: In working steam expansively in the ordinary reciprocating engine, does it make any difference whether the port is left wide open during the first part of the stroke and entirely closed during the remainder, or whether the port is but partially open during the entire stroke, the width of the opening, in the latter case, being of course regulated by the desired degree of expansion? Answer: It is much more economical to work the engine as mentioned in the first case.

J. B. M. says: I have an engine that requires 40 lbs. pressure, but sometimes I have extra heavy work and have to run it at 60 lbs. Will it take any more fuel to keep the pressure at 60 lbs. all the time, provided that there is no escape of steam through the safety valve? Answer: Theoretically, it takes scarcely any more fuel to make steam of 60 lbs. pressure than it does of 40 lbs.; but in practice, there is a noticeable difference in the amount of consumption in the two cases. It will be ordinarily more economical, however, to carry steam at the higher of the two pressures.

J. S. M. asks for an easy rule for setting a slide valve with a link motion? How would you set a cut-off, made of two plates sliding on the back of the slide valve, with a right and a left hand double thread on the stem, they being drawn together by a wheel on the top of the stem? How can I set out the rings of the steam piston? How shall I key up the connections with the crank pin and cross heads? How can I set the boxes to the other bearings, especially the thrust bearing? What is the best thing to prevent foaming or to prevent the water from being drawn over from the boiler into the engine? Is it a good plan to give a boiler plenty of steam room, so that the steam may clear itself of the water that is apt to rise with it? Answer: We are glad to receive a letter containing such intelligent questions; but our correspondent, without perhaps being aware of it, has made inquiries that could only be answered by a lengthy treatise on marine engines. He must study such things for himself; and while he will find many valuable hints in our paper, he can only master the subject by diligently reading the best text books, and carefully investigating the best practice.

T. T. says: We have a well about 40 feet from a pond, and want to lay a one inch iron pipe under ground, from pond to well: how can we do this without draining the pond? We want to lay it about 4 or 5 feet below the surface of the water. Answer: Perhaps you had better lay the pipe in another manner. If the well is below the pond, a siphon will answer very well, and can be easily applied.

B. M. asks: How can I mix chalk or other precipitate with either alcohol or water, so that there will be no sediment at the bottom? By what process can it be brought to a creamy appearance? Answer: The nature of a precipitate is insolubility. Chalk is insoluble in water or alcohol, and therefore precipitates or falls to the bottom as a sediment. You cannot change the chemical properties of chalk in this respect. You can only keep up a creamy appearance of a mixture of chalk and water by frequent stirring.

H. M. B. asks: What is the best mode of extracting, from linen or clothing, the stains produced by the tincture of muriate of iron, after they have been washed? Answer: Soak in solution of oxalic acid, and wash thoroughly. Oxalic acid is poisonous when swallowed.

H. J. B. Jr. asks our opinion of a system of hydraulic rams for propelling water for extinguishing fires. Answer: Probably when steam is not used in a building, this would be a good arrangement. But when steam is available, a steam pump could be made more effective and quicker in its operation.

D. A. I. asks: Can you inform me of the best method of coating paper with a coloring matter, such as an aniline dye, the object being to have the coating as thick as possible without scaling off readily? The color at the same time should be soluble in water. I have tried common gum arabic, but, while it prevents scaling off, it is insoluble in water, and is very difficult to work. Answer: Try a very weak solution of gum arabic. This has very slight consistency, and, while preventing scaling, cannot be difficult to work.

A. M. R. asks for information concerning the most recent process of making malleable iron castings, on a large and small scale. Answer: A process of making malleable iron castings is to heat the castings to redness while imbedded in powdered chalk or charcoal, or oxide of iron (hematite, for instance), so as to protect from the action of the air, and decarbonize the cast iron. See Osborn's "Metallurgy of Iron and Steel," and "The Manufacture of Steel," by Grüner.

J. T. B. says: A friend and I have a question *sub judice*. He contends that, in the construction of an ear trumpet, it is of great importance that the material be such that it will increase the sound which it transmits, such as light metal or other material capable of sonorous vibrations while I, on the contrary, maintain that the whole design of the ear trumpet is for the purpose of collecting and transmitting or conducting the sound already produced, and that it should be constructed in bell form merely to collect the sound waves and thus make a direct impression on the *membrana tympani* with greater force. I contend that the form has more to do, with its effectiveness as an aid to hearing, than the material of which it is constructed, and that it being sonorous or capable of vibration does not increase the sound or make it more easily heard. Which is right? Answer: It is generally considered that it makes very little difference of what material the instrument is constructed, or what is its form, provided only that the outer opening is greater than that which enters the ear. The effect of this is to transmit the sound vibrations to portions of air continually growing smaller, thus increasing the intensity, as the vibrations approach the ear.

R. H. asks: 1. In which case has a vessel the greatest buoyancy, when filled with atmospheric air, with compressed air, or when exhausted of air altogether? 2. What is the relative buoyancy? 3. Give a rule for finding the weight which a given quantity of air will support in sea or fresh water. 4. What is the best shape for buoys? 5. What amount of horse power would be required to move a horizontal column of water 3 feet diameter and 30 feet long at the rate of 20 miles an hour, the column discharging horizontally against an open body of water 3 feet below the surface? 6. What resistance would be offered by the open body of water? Answers: 1. When exhausted. 2. Common atmospheric air weighs about .0765 pounds per cubic foot, compressed air at a pressure of two atmospheres weighs twice as much, and so on. 3. Weight which can be supported by a floating body is equal to the weight of the displaced water. 4. They are usually made conical. 5 and 6. We cannot answer these questions without some further particulars being given. If, as we suppose, the questions are asked in reference to propulsion by a water jet, we must refer you to some good treatise on the subject.

T. R. B. asks how to get the exact radius for a link for an engine? Answer: We think you will find full and correct information on this subject in "Link and Valve Motions," by W. S. Auchincloss.

M. H. asks: Will linseed oil mixed with slaked lime do to paint old buildings with? Answer: Linseed oil and slaked lime when mixed together will form a soapy compound, not suitable, we should imagine, for a paint. You want for a body some substance that will not chemically combine with the oil, such as red oxide of iron or red ochre, a favorite color in some localities. You can shade down with whiting or fine chalk.

C. P. asks for the best method of restoring the colors of faded carpets, and removing grease spots. Answer: You can remove grease spots from a carpet by soaking it with benzine or naphtha, by means of a rag. We know of no way to restore the faded colors in a carpet.

W. B. J. asks: What material must I use to make a tough elastic mold for casting center flowers in plaster of Paris? Answer: Use a mold of gelatin, and a cold setting plaster.

C. R. C. asks: How can I make powdered soapstone perfectly white? Answer: The coloring matter of soapstone is due to some metallic oxide in its composition. You might try the action of dilute oil of vitriol upon it in a very finely powdered condition.

G. B. asks: What salts and gums are the most affected by the weather? Answer: The most deliquescent salt, or one that attracts moisture the most, is the chloride of calcium. The gums, on the contrary, have generally the property of parting with their combined water, and drying when exposed to the air.

S. C. A. says: In Colorado the atmosphere is clear and dry. Persons on their arrival there find it very difficult to perform any active labor on account of the difficulty in breathing, until they become acclimated. This is more noticeable in sickly persons, or persons with weak lungs. Is it to be accounted for by there being a less per centage of oxygen in this pure, dry atmosphere? 2. Must the lungs expand to allow one to inhale sufficient air to obtain the required amount of substance to sustain life? Answer: You are right in saying that oxygen is essential to the lives of animals, and that the lungs are provided for the purpose of absorbing it, thus oxidizing the blood and keeping up the standard of animal heat necessary to life. On the mountain heights of Colorado, the air is less dense than that at the sea level, and consequently, bulk for bulk, contains less oxygen. It follows from this fact that, where you live, the lungs must inhale more air in a given time, in order to obtain the required amount of oxygen, and consequently one must breathe faster. It would naturally take some time for the lungs of persons who are accustomed to breathe dense air to become accustomed to a comparatively rarified atmosphere, and this change of air would affect sickly persons or those with weak lungs more than those with sound ones.

J. W. R. asks: By what process can I obtain the greatest amount of carbon? Answer: That depends upon the kind of carbon wanted. Charcoal is one kind, and a very compact variety forms sometimes in gas retorts. Lampblack is nearly pure carbon.

J. F. W. asks: What metal is the best conductor of electricity? Answer: Silver is the best conductor of heat and electricity known.

S. T. B. asks: What battery power will it require to heat red hot a platinum sheet, 5 inches square and the thickness of a sheet of writing paper? Answer: Supposing the platinum to be the one hundredth of an inch thick, about seventy five cups of the largest size of Bunsen's battery, all well connected and in active operation, will be needed.

G. A. asks for a simple method, suitable for class illustration, of producing a current of electricity by light, to show the relations of heat, light, electricity, and chemical force. Answer: Adjust a prism so as to get a well defined polar spectrum, bring the violet rays to a focus on the eye of a fine cambric needle made so hard that it will scratch glass; this will magnetize the needle, proving that light will produce magnetism, by which a current of electricity may be induced in a small coil of very fine wire connected with the binding posts of a sensitive galvanometer; a slight movement of the galvanometer needle each time the magnetized cambric needle is caused to enter the coil, and a movement in the opposite direction when it is withdrawn, delicately prove the correlation of light to magnetism and electricity.

H. W. S. Jr.—In the compound engine, the use of the steam by a second cylinder is secured in a manner better than that which you propose.

F. J. S. says: 1. Is the "Science Record" an illustrated work? 2. What is the approved theory of the magnetic force which controls the needle of a compass? 3. What is the variation of the compass at New York? 4. What is the cause of the variation which the magnetic needle makes with the true meridian? 5. How is lodestone obtained? Answers: 1. Yes. 2. It is quite reasonable to regard the earth as an immense magnet, whose south pole is at its north geographical pole, and consequently attracts the north pole of the needle. 3. About two degrees west of north; the variation is not fixed, and is more or less every day in the year, and frequently several times in a day. 4. It is supposed to be caused by local electric action. 5. It is a valuable lower oxide of iron, and is found in the ground as an ore.

D. M. B.—The machine you describe in your communication does not seem to us to embody any novel features. The fact that a heavy body, when put in motion, requires considerable force to stop it is by no means new. The announcement that you get rid of the resistance is scarcely worthy of comment, as it amounts to saying that you have created power. You must excuse us for not being willing to give up what you are pleased to call the old theory of the lever. If your machine really destroyed resistance, it would accomplish this equally well whether running fast or slow; and in such an impossible machine, a pound weight, hung on a point where the power is applied, would, in falling a foot, raise something more than a pound (suspended there to represent the resistance) through the same space.

E. T. asks: Does the burning of coke affect the iron of a boiler more than coal? Answer: We think not.

D. K. S. asks: Will corn meal put into a steam boiler injure the iron? I find after 6 months use of it (put in to stop a leak) that my boiler is as clean and free from scale as when new. Answer: We think not.

W. H. F. asks: Are any oscillating engines made in this country with cut-off valves? As far as I can learn, they are all made to open and close their ports by the oscillation of the cylinder, and are therefore invariable in their action. I wish to procure, if possible, two oscillators wherein I can regulate the steam as with a link motion. Answer: We have seen such engines as you describe, but it would probably be necessary for you to have them built to order, as we do not think they are regularly in the market.

J. J. R. asks: For a small steam yacht, say 20 or 30 feet long and 5 or 6 feet beam, which is the steadiest, fastest and cheapest, as far as machinery is concerned, a side wheel or propeller? Where space is not so much an object as speed and steadiness, which is preferable, an upright or horizontal engine and boiler? Answer: The side wheel will be the steadiest, and the screw propeller the faster and cheaper. For such a small boat, a horizontal boiler is hardly practicable, and the upright boiler can be made of large diameter and low, so as not to affect the steadiness of the little steamer.

T. H. says: The English plan of sounding in deep water is to attach a block to one of the yard arms; then another block is secured to the end of a rope which is rove through the yard block and secured to the main rail by elastics, the second block being hauled close up to the yard block. Then the sounding line is rove through this second block and the sinking weight and grapnel attached. The line is marked with a conspicuous mark at each hundred fathoms and told off by the officer in charge as the line runs out. A large number of pins are placed in the main rail on which the line is carefully placed in coils, and a man is detailed to see that the line runs off clear. A small engine connected with a winch is employed to haul in the line. Two or three turns are taken around the winch head with the line, and held by an experienced man who allows it to surge whenever an overstrain comes on the line by the ship's motion; and yet, with all possible care the line is often parted and lost. 1. What proportion of the strain of the line is due to pressure? 2. If a round spar of white pine, 10 feet long and 6 inches diameter, were attached to a weight sufficient to sink it rapidly to the bottom in 5,000 fathoms water, weight detaching itself on striking bottom, would the spar have sufficient buoyancy to return rapidly to the surface with 10 pounds weight attached? 3. To what size would the spar be reduced by the pressure? 4. Would it retain its original weight under the pressure? 5. Is there any agent that can be employed that will return rapidly to the surface with 10 pounds weight attached from 5,000 fathoms depth, which will not require more than 100 pounds to each 1,000 fathoms to sink it rapidly? Answers: We presume that the strain on the line is due to its own weight and the friction of the water, the weight of the line being greatly increased by its becoming soaked. If the white pine spar were thoroughly dried, it is doubtful if it would be sensibly compressed, as it would readily absorb water, until all its pores were filled. It would be impossible to tell without experiment how much water it would absorb, under the pressure to which it would be exposed, but probably not more than it contains when just filled—in which case it would weigh from 30 to 33 pounds per cubic foot. As the weight of the displaced water would be something more than 64 pounds per cubic foot, it is evident that the spar would rapidly rise to the surface. If it could be coated with some preparation to exclude water, its weight would be only about 25 pounds per cubic foot, and it would rise more rapidly. Perhaps some of our readers have made experiments, to find how much the weight of a wooden float is increased when it is submerged; and if so, we would be glad to hear from them. It might be better, instead of using a spar, to sink a bag or a telescopic cylinder which contains a mixture that would form gas of considerable pressure when the weight was detached. The effect of this would be that the bag would be inflated, or the cylinder lengthened, and in either case, as the bulk of the submerged body would be largely increased while its weight remained the same, it would rise rapidly. The advantage of this arrangement would be that it could be submerged by a small weight, in comparison with that required for a body with constant volume.

F. M. H. asks: 1. What sized pipe will I require to convey steam 600 feet from a two flue boiler 12 inches diameter by 20 feet long to a four horse power engine, the pipe not to be coated? If the pipe be coated, what per centage of steam will be saved? 2. Do we get as much power with a turbine near the top of the penstock as at the bottom, the latter being full of water when started? The turbine is supposed to run by suction, as the water flows through the turbine and keeps the penstock full. 3. Is it practicable to bore artesian wells to run water engines? At what depth is water usually found where springs are numerous? Answers: 1. About 1 1/2 inches in diameter. By properly coating the pipe, you will effect a great saving, probably more than 25 per cent. 2. We would recommend the wheel to be placed as low down as is convenient. 3. Water can be obtained in some localities, by digging down a few feet; but borings for artesian wells must generally be made to a considerable depth, in any locality. It is not usual, however, to construct them when there is plenty of water close to the surface. The boring machinery can be driven by water wheels. There are two artesian wells, close together, in the city of Chicago, and the machinery for boring the second one was driven by a wheel propelled by water from the first.

J. C. S. would like to know the maximum power transmitted under following circumstances: "Our driving pulley is 8 x 24, and runs at rate of 130 revolutions per minute; the driven pulley is 8 x 24 and is distanced from driving pulley 28 feet. Belt runs nearly horizontally. The day it was put on (as tight as could be, with stretcher) 12 inches was cut out in consequence of its becoming too slack; next day 22 more inches was cut out; and today the belt is slack. A rule laid down by your paper gave 11,000 feet per minute to the inch for a horse power, making this belt about 5 horse power; according to a test by a practical man with a dynamometer, as described in the SCIENTIFIC AMERICAN, it would produce over 11 horse power. If the belt is strong enough and does not slip, this is not a very good rule for calculating its power." Answer: The rule referred to probably gives average results, and not the maximum amount of the power that can be transmitted by a belt. We shall be glad to hear of reliable tests on the subject; and if we receive enough data, we will correct the formula.

W. B. E. asks: Why will not direct acting steam pumps work with single slide valve alone, without having auxiliary piston and tappet valves to move the slide valve? Answer: We believe the first direct acting steam pump was made as you describe; but it is found easier to regulate the stroke of the pump by using tappets and an auxiliary piston, because in this case the motion of the piston is reversed with little expenditure of power.

W. J. R. asks: 1. What horse power, theoretically, ought one pound of good bituminous coal to furnish? 2. Given a mine in which the air travels two miles through gangways 8 x 6 feet, with difference in elevation of pit mouths 50 feet, increased 50 feet by furnace stack: Supposing that you can burn, theoretically, one ton of good bituminous coal per day, what is the greatest velocity and amount of air you can draw through in a day? Answers: 1. Theoretically, every pound of good bituminous coal burned per hour would develop about 5 1/2 horse power, if its whole effect were realized. 2. You do not send enough data to enable us to answer this question.

W. B. E. says: Your answer in regard to two pumps discharging into one pipe was incorrect. To increase the quantity of fluid discharged, you must increase the pressure. Answer: We have already explained this matter, and until we see it clearly proved that a small steam fire engine throws as much water as one double the size, with same steam pressure and number of strokes, we do not feel inclined to alter our opinion.

H. A. D. asks: 1. In turning a curve, does one wheel of a locomotive turn any faster than the other, and if so, how, both being secured to the same axle? 2. Can a locomotive with two driving wheels, connected by the rod, travel as a locomotive with only one driver? Answers: 1. No. 2. Yes, if we understand the question.

A. P. Y. asks: Can a boat sail faster on a tack, that is, going against the wind, than when going directly before the wind, the velocity of the breeze being the same in both cases? Answer: A sailing vessel, under some circumstances, goes faster on a tack than before the wind. You will find an article on the subject, on page 177 of our volume XXVIII.

B. A. S. asks: 1. What are the methods of ascertaining where iron ore is to be found other than digging? What peculiarities of soil, or other surface indications, are there, which denote the presence of iron ore, and what indications are incompatible with it? 2. Can a miner's or dip needle be relied upon, and can any one use one? 3. Is your paper as good as any to advertise an ore bed for sale? Answers: 1. Consult some reliable work on geology. 2. The miner's needle is chiefly employed to locate veins in mines. 3. We think so. See page 141 of this issue.

T. O'N. asks: Is the arrangement shown in the diagram the proper one for a belt from A to drive a shaft on B at a right angle, both shafts being horizontal, and one about twenty feet above the other? When driving a horizontal shaft, from an upright one, will the pulleys have to be arranged in the same way, and will the belt lead from the driver to the driven, as in the case of the two horizontal shafts? Answer: When transmitting power with a quarter turn belt from one horizontal shaft to another, also horizontal, at right angles to it, guide pulleys are generally employed. When one shaft is horizontal, and the other vertical, the arrangement shown in your sketch will answer, if there is sufficient distance between centers.

E. W. H. asks: 1. What is the fireproof composition used in the manufacture of safes? 2. Would not the same material placed on the outside of and around a steam boiler confine all the heat to the inside of the boiler? 3. Are these non-conducting compounds patented? 4. Are the materials expensive? Answers: 1. Safe fillings are generally made of gypsum, alum, hydraulic cement. 2. No, not at all. But the use of a jacket of non-conducting material saves much fuel. 3. There are several patents. 4. No.

W. A. M.—The reason why your plan will not work is the same as would be assigned in case a solid weight were used to sink the receiver, instead of the weight of the compressed air.

C. J. B. asks: How can I regenerate ink that has been frozen? Answer: Prussiate of potash will not regenerate frozen ink, though it will bring out writing written with such ink. When potassium ferrocyanide or yellow prussiate of potash is added to a solution of ink, iron ferrocyanide or prussian blue is formed. We know of no method to regenerate frozen ink, its pale color after freezing being due to the decomposition of the organic matter (galls) contained in it.

G. W. B. asks: How can ordinary dark brown maple sugar be clarified so as to be made of a much lighter shade? 2. How can I tan deer skins so they would be suitable to make up into hunting jackets, leggings, etc.? Answers: 1. Dissolve the sugar in water, add whites of eggs to the solution; heat to the boiling point; and skim off, while boiling, the impurities from the top. While still hot, filter through recently burnt animal charcoal (bone black). Boil again to the crystallizing point, and then run off into molds, etc. 2. Soak the skins in lime water, and cleanse as perfectly as possible. Then soak in dilute oil of vitriol to open the pores of the skin. Then soak in an infusion of oak bark or tannin until sufficiently tanned.

E. E. G. asks: How can double sulphate of nickel and ammonia be made from the sulphate, for a plating solution? Answer: Add aqueous strong ammonia to a warm (not hot) saturated solution of nickel sulphate, cool, evaporate in a vacuum or without boiling, and collect the light blue crystals that form.

C. R. C. asks: Can rubber be made pure white, so as to receive a good polish and not altogether lose its elasticity? What work treats upon the subject of rubber? Answer: Crude commercial rubber is colored dark by the smoke of the fire used in drying it. To obtain it pure, mix the fresh white juice with 4 or 5 times its weight of water; let it stand for a day and then heat, and skim off the layer of rubber that rises to the top. Repeat until all the gum is extracted, and then press between folds of cloth. You might mix this pure white gum with white lead, or similar body, to harden it, but the proper manufacture of what you seem to be looking for can only be attained by careful experiment. See Muspratt's "Chemistry," and Tomlinson's Encyclopedia, article caoutchouc.

Mrs. H. H. asks: How can I make fibrin from albumen? Answer: Put the whites of a dozen eggs in a gallon of water. Let them soak for 12 hours, and then raise the same water containing the eggs to the boiling point. Continue the boiling for 10 or 15 minutes.

W. E. T. asks: Are not lightning rods much safer conductors if perfectly insulated? Answer: The rod should be attached directly to the house without insulators.

H. W. S. asks: What is the general rule for calculating solar and lunar eclipses, and what is the best text book on the subject? Answer: Eclipses of the sun and moon recur every eighteen years, eleven and one third days, in nearly the same order. They occur whenever a lunar conjunction or opposition coincides with one of the moon's nodes. See Burritt's "Geography of the Heavens," pp. 214-224, or Chauvenet's "Spherical and Practical Astronomy," pp. 436-521.

A. S. asks: 1. What is the best kind of a battery to attach to a steam boiler to prevent lime from sticking to it? 2. What is your opinion of using an electric current to prevent scale from forming in boilers? I have seen batteries used for that purpose, and hear them highly spoken of. Answers: 1. One that is constant, such as Leclanche's and Daniell's sustaining battery. 2. We should think, having no positive evidence to the contrary, that so much battery power would be required to do efficient service that it would hardly pay.

W. A. B. says, in answer to A. D. W., who asked how to deposit a thin film of lead on iron: Dissolve the acetate or nitrate of lead in water. Precipitate the lead with a strong solution of carbonate of potassa, adding it drop by drop till no further effect is produced. Pour off the supernatant liquid, and wash several times in water, and then add a solution of cyanide of potassium, say two ounces to the gallon of water, to redissolve the precipitate. By employing this solution in a weak state, with moderate battery power, I have coated articles admirably. The iron must be well cleaned in a pickle.

O. C. says, in reply to O. C. W.: I would say that high water is the easiest to make steam with. If any one doubts this, let him run his boiler, say one day with water between the lower and middle gages, and the next day with water above the top gage, and he will see which is the easier.

J. E. C. asks: Which is the best water for drinking and household purposes: water obtained from a drive pipe well, or by the common well, providing that the latter is cemented up from 5 feet from the bottom, both having the same kind of pipe and pump? Answer: Whether the water be obtained from a drive pipe well or an ordinary one will make no difference as regards the quality of the water for household or drinking purposes, other things remaining the same.

W. B. asks: What can I use to remove ink stains from a pair of tweed trousers? Answer: Rub a little melted tallow on the spot, and then wash; or apply lemon juice, or a little powdered cream of tartar made into a paste with hot water.

B. H. B. says: In your issue of June 14, you give a mode of fining hooks and eyes, pins, etc. I wish to apply the process, and I ask for the proportion of the ingredients of the recipe. Answer: You can tin articles of iron by first dipping them into dilute oil of vitriol to clean their surfaces and then into a bath of melted tin.

J. S. B. asks: What is paint or plumbago mixed with to make a composition fit for filling pencils? Answer: The plumbago used in lead pencils is generally mixed with clay and moistened with water, then pressed into the form desired.

E. asks: How can mold stains be removed from books without injuring the paper? Answer: You can whiten papers discolored with mold in the following way: 1. Wet with pure clean water. 2. Soak in a dilute solution of bleaching powder. 3. Pass through water made sour to the taste by muriatic acid. 4. Soak in pure water until all traces of acid are removed, and dry. It is not necessary to say that this operation requires careful manipulation. You may try, instead, exposing the moistened paper to the fumes of burning sulphur, which is a good bleaching agent, and then passing it through water and drying.

T. S. asks: How can I make the portable ink of Professor Bottger, described by you in your issue of March 1? Answer: Make the strongest possible solution of aniline black in water or alcohol. Soak thick unsized paper thoroughly until it is as dark as the solution, and then dry.

J. G. says: I have broken about two dozen of good new files. How can I fix them? Can they be soldered in any way? Answer: You might secure the pieces for use upon a wooden bar. We think you could not solder them.

D. S. H. asks for a formula for calculating the power of a falling weight. Answer: Theoretically, the work done by gravity equals the distance the weight falls multiplied by the weight. The mean pressure on the pile is equal to the work, divided by the distance the pile enters in feet. Example: Suppose the weight is 2,500 pounds, and falls 25 feet, forcing the pile into the ground 18 inches. Work of weight = 2,500 x 25 = 62,500 foot pounds. Mean pressure on pile = 62,500 ÷ 1 1/2 = 41,666 2/3 pounds.

L. M. C. asks: What will be the best cement for mica, to stand a good heat, such as that of a lamp? Answer: The following is a recipe for a fireproof cement for mineral substances: Fine river sand 20 parts, litharge 2 parts, quick lime 1 part, linseed oil to form a thin paste. Let it harden before applying heat.

S. D. E. asks: What is the proper focal distance for a 2 foot reflector, and how large should the small reflector be to correspond? Answer: A 2 foot reflector should be of 20 feet focus, that is, the radius of curvature should be 40 feet. The plane mirror should be about 3 x 5 inches. See page 43 of our current volume.

E. J. L. says: 1. Suppose a half inch pipe is inserted in the end of a barrel, the pipe extended to a perpendicular height of 33 feet, and water poured in till full; will there be sufficient pressure on the pipe to burst the barrel? 2. What will be the pressure, and what is the rule to ascertain the pressure? 3. If a one inch pipe is placed instead of the above pipe, at the same height, will there be any difference in the pressure? If any, how much? Answer: 1. It will be nearly correct to estimate the water pressure at half a pound per square inch for every foot in height of the water column. Whether your barrel will stand the pressure of a water column 33 feet high depends on its strength. 2 and 3. The pressure on the barrel would be about 15 pounds to the square inch.

D. M. says: On page 75 of your current volume, I. M. B. asks why the images of objects, being reversed upon the retina of the eye, are yet apparent to us in their proper positions. "May I ask I. M. B. if he knew, before he studied natural philosophy, that there was upon the retina of his eye an image of objects seen by him? It will, I think, be readily granted that the object of vision is not the image upon the retina, but the thing of which it is the image. In other words, what the faculty of sight apprehends is the external object, not the image of it upon the retina. This image is, not the object of the faculty, but the means by which the faculty elicits the act of seeing; not that which we see, but that by means of which we see. If the spectator is not conscious of the image upon the retina of his eye, if he has no knowledge of it in the act of vision, then the difficulty proposed by I. M. B. vanishes; for that difficulty arises from his assuming that what we see is the image upon the retina, while in fact no man has a direct knowledge of that image, but only a reflex knowledge, acquired by studying natural philosophy. I. M. B. should have asked: Why, the images of objects being reversed upon the retina of the eye, we nevertheless see the objects in their proper positions? The question thus laid down presents no serious difficulty.

I. G. points out, in reply to J. E. E.'s question as to the phosphorescence from fire flies and glow worms, that the light is only emitted by the females during the copulating season.

D. B. M. says, in answer to several inquiries as to how to determine the meridian of any locality: On some clear night, suspend two plumb lines at any con-

venient distance apart, and align them as exactly as possible with the pole star. Twelve hours afterward observe them again, when, without the merest chance, they will not be in alignment with the star. Align them again by moving either of the lines to the east or west as may be necessary. The first position of the line moved should be carefully marked before moving it. Find the middle point between the first and second positions of the line moved, suspend the moved line at this point, and the two lines will hang in a true meridian line. Of course this method can be used only when the nights are somewhat more than twelve hours long. A lantern, properly shaded, will be found useful in making the alignments. A moonlight night is not very suitable, because the star is not then so distinct. Trouble will sometimes be caused by the wind. This may be very much lessened by allowing each plumb to hang in a vessel full of water.

W. A. B. says that a piece of brown paper, folded two or three times and placed between the upper lip and the gums, will immediately arrest bleeding at the nose. Press the lip gently with the finger so as to hold the paper firmly. It never fails.

O. C. says: I would suggest to A. K., who asks for an invisible ink, that sulphuric acid greatly diluted with water will be invisible until gently heated, when it will become a jet black, if rightly proportioned. If too much acid is used, it will eat the paper.

J. E. S. says, in reply to J. H., who asked for a rule to determine the position of the frets on the finger board of a guitar: The following is available for ordinary use: Divide the length of the string from nut to bridge into eighteen equal parts; take one of these parts for the space between nut and first fret. Then divide the distance between that fret and the bridge into eighteen parts and take one of those for the second fret, and so on, always shortening the string one eighteenth to raise the pitch a half tone. This, if accurately spaced, will bring the octave fret a little below the center of the string, which is as it should be to produce a perfect octave; for although the absolute center is the point for the harmonic, the string, being in higher tension when forced on to the fret, gives too high a tone if the fret be in the center. To space for the frets with compasses in the ordinary way, if done with any degree of accuracy, is a slow and tedious job, but by adopting the

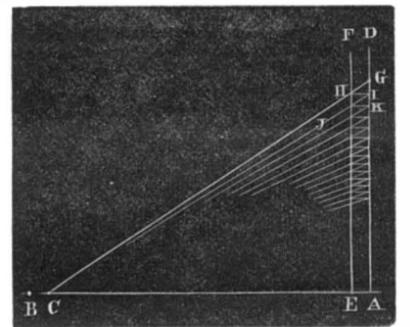

method shown in figure, it will become simple and interesting. Upon a drafting board, with square and straight edge, make the base line AB some three or four feet long; set a pin at the point C and erect two perpendicular lines AD and EF, which shall be one eighteenth of the distance from A to C apart, that is, if it is 36 inches from A to C, then from A to E will be 2 inches. Lay off on the line AD the length of the guitar string as at C, and with the straight edge strike the diagonal G C; from the intersection H draw the horizontal I, which gives the position of the first fret. The diagonal J and horizontal K give the position of second fret, and so on to full number. The finger board spaced in this way will not be likely to correspond exactly with the finger boards on the guitars made by regular makers, nor do those of different makers agree, from the simple fact that any instrument that makes the same tone for the sharp of one note and the flat of the next is an imperfect instrument, as there should be something like a quarter or third of a tone difference; so when a single tone is used for the two, it is but a compromise at best, and the compromise made by the regular spacings is as good as any, for the difference is so slight as not to be discernible by the ordinary ear. If one has a guitar of which the location of the frets is satisfactory and wishes to transfer the same proportions to another, where the finger board is either longer or shorter, the use of this same triangular draft is available and perfect. Make the triangle as above, only move the two vertical lines until their lengths shall correspond with the two different lengths of strings, transfer this portion of the frets on to one of the lines, and draw the diagonals, which will give the other.

MINERALS, INSECTS, ETC.—Specimens have been received from the following correspondents, and examined with the results stated:

S. H. C., to whom we submitted certain minute insects, found as parasites on the common fly (sent to us by another of our correspondents), reports that he has examined the specimens under the microscope. He also sends us sketches of their appearance under the instrument, with descriptions. From the natural size, less than half the diameter of the head of a pin, our correspondent has magnified them up to formidable looking monsters six inches in length. He states that they belong to the group *acaridea*, and are probably members of the fourth family, or *hydrachnida*.

A. F. S.—The bright brassy crystal is iron pyrites, or sulphide of iron.

C. O. T.—All three are iron pyrites, a compound of sulphur and iron, of value when in sufficient quantity for the manufacture of oil of vitriol.

K. J. J.—The black specimen appears to be slate. The other specimen contains plumbago.

G. W. A.—The metal looks like zinc.

R. S.—Your specimen is probably the humming bird moth, which is often mistaken for the bird.

R. H. McG.—The metallic specimen seems to be an alloy of silver and lead; the other material is bituminous coal.

J. M.—The article enclosed is a kind of grass which has certainly taken on a hue of wondrous green, derived from the spent products of the dye house in which it was found.

E. A. S.—Iron pyrites.

J. S. T.—The enclosed specimens are iron pyrites, of value if in large quantities and near transportation.

J. A. E.—Your mineral resembles oxide of iron. An analysis will cost \$10.

J. R. W.—The metallic composition of this mineral can be determined only by a careful assay. Cost \$10.

COMMUNICATIONS RECEIVED.

The Editor of the SCIENTIFIC AMERICAN acknowledges, with much pleasure, the receipt of original papers and contributions upon the following subjects:

- On the Composite Lens. By A. F. K.
On Letting Air into Pumps. By E.
On the Water-Cooling Monkey. By J. W. H.
On Hot Air Engines. By F. G. W.
On Algebraical Problems. By M.
On Lunar Acceleration. By J. H.
On the Hight of the Atmosphere. By S. B.
On the Zodiacal Light. By T. R. L.
On How Planets are Ruined. By H. C. F.
On Large Pumping Engines. By W. L. C.
On the Sun's Heat. By W. C.
On the Million Dollar Telescope. By F. M. B., and by J. P. W.
On the International Patent Congress. By B. B. H.
On Propulsion on Canals. By F. G.
On Caloric Engine Valves. By F. H. R.
On the Patent Right Question. By W. R. R.
On Patent Wrongs. By W. P. P.
On a Balloon Valve. By S. W. G.
On an Improved Journal Box. By C. W. C.
On a Theory of Heat and Light. By J. A. H.

Also enquiries from the following:
H. J. C.—P. S. A.—C. A. C.—W. B. N.—W. E. M.—C. R.—R. D. J.—G. H.—F. Z.—J. H. C.—J. A. G. & Bro.—S. M. L. Jr.

Correspondents who write to ask the address of certain manufacturers, or where specified articles are to be had, also those having goods for sale, or who want to find partners, should send with their communications an amount sufficient to cover the cost of publication under the head of "Business and Personal," which is specially devoted to such enquiries.

Correspondents in different parts of the country ask: Where spark arresters can be obtained, suitable for chimneys in which shavings are burned? Who make reliable wind mills for pumping water? Where can the best fire extinguishers be obtained? What is the price of, and where obtained, the best cement for jacketing steam boilers? Where can diamond drills be purchased? Makers of the above articles will probably promote their interests by advertising, in reply, in the SCIENTIFIC AMERICAN.

[OFFICIAL.]

Index of Inventions

FOR WHICH

Letters Patent of the United States WERE GRANTED FOR THE WEEK ENDING

July 29, 1873,

AND EACH BEARING THAT DATE.

[Those marked (r) are reissued patents.]

Table listing inventions and their patent numbers, including Alarm, burglar, M. H. Perkins, Auger bits, machine for forming, J. Swan, Auger, earth, S. H. Dickerson, etc.

Table listing inventions and their patent numbers, including Electromagnetic date stamp, J. C. Hinchman, Engine, ammonia, W. H. Smith et al., Engine, rotary, G. W. Cummings, etc.

Table listing inventions and their patent numbers, including Teaching apparatus, school, M. McVicar, Thread cutter, M. J. Pfitrat, Trap, animal and insect, W. W. Hannah, etc.

APPLICATIONS FOR EXTENSIONS.

Applications have been duly filed, and are now pending for the extension of the following Letters Patent. Hearings upon the respective applications are appointed for the days hereinafter mentioned:

- 25,936.—ENGINE CUT-OFF.—E. R. Arnold. October 15.
26,003.—TELEGRAPHIC MACHINE.—G. M. Phelps. Oct. 15.
26,060.—BOX JOINT MACHINE.—J. Stimpson. Oct. 22.
26,069.—SLEEPING CAR.—J. Danner. October 22.

EXTENSIONS GRANTED.

- 24,947.—JOURNAL BOX.—J. A. Montgomery.
24,987.—FISHING REEL.—W. Billingham.
25,061.—ELEVATOR.—O. Tufts.
25,015.—WOOD SAW FRAME.—J. Haynes.

DISCLAIMER.

- 25,061.—ELEVATOR.—O. Tufts.

DESIGNS PATENTED.

- 6,785.—MONUMENTAL URN.—N. Brayer, Rochester, N. Y.
6,786 to 6,789.—OIL CLOTHS.—C. T. Meyer, Lyon's Farms, N. Y.
6,790.—CARPET.—H. Smith, Kidderminster, Eng.

TRADE MARKS REGISTERED.

- 1,383.—CIDER, ETC.—Berlin Mineral Water Co., Boston, M.
1,384.—BLUING PAPER.—Dole Brothers, Boston, Mass.
1,385.—APPLE PAPER.—D. H. Goodell, Antrim, N. H.
1,386.—PRESERVING LEATHER.—J. G. North, Brookline, M.
1,387.—BUTTER.—S. Straight & Son, Hudson, O.
1,388.—CHEWING TOBACCO.—Wall & Co., St. Louis, Mo.
1,389.—MEDICINE.—C. D. Bradley, Taunton, Mass.
1,390.—SOAP.—J. O. Draper & Co., Pawtucket, R. I.
1,391.—ROOT BEER.—S. F. Stowe, Providence, R. I.
1,392.—MEDICINES.—Wilson Carbolated Cod Liver Oil Co., New York city.

SCHEDULE OF PATENT FEES:

Table listing patent fees: On each caveat \$10, On each Trade-Mark \$25, On filing each application for a Patent (17 years) \$15, etc.

VALUE OF PATENTS, And How to Obtain Them.

Practical Hints to Inventors

PROBABLY no investment of a small sum of money brings a greater return than the expense incurred in obtaining a patent even when the invention is but a small one. Large inventions are found to pay correspondingly well. The names of Blanchard, Morse, Bigelow, Colt, Ericsson, Howe, McCormick, Hoe and others, who have amassed immense fortunes from their inventions, are well known. And there are thousands of others who have realized large sums from their patents.

HOW TO OBTAIN Patents

This is the closing inquiry in nearly every letter, describing some invention which comes to this office. A positive answer can only be had by presenting a complete application for a patent to the Commissioner of Patents. An application consists of a Model, Drawings, Petition, Oath, and full Specification. Various official rules and formalities must also be observed. The efforts of the inventor to do all this business himself are generally without success. After great perplexity and delay, he is usually glad to seek the aid of persons experienced in patent business, and have all the work done over again. The best plan is to solicit proper advice at the beginning. If the parties consulted are honorable men, the inventor may safely confide his ideas to them; they will advise whether the improvement is probably patentable, and will give him all the directions needful to protect his rights.

How Can I Best Secure My Invention?

This is an inquiry which one inventor naturally asks another, who has had some experience in obtaining patents. His answer generally is as follows, and correct: Construct a neat model, not over a foot in any dimension—smaller if possible—and send by express, prepaid, addressed to MUNN & Co., 37 Park Row, together with a description of its operation and merits. On receipt thereof, they will examine the invention carefully, and advise you as to its patentability, free of charge. Or, if you have not time, or the means at hand, to construct a model, make as good a pen and ink sketch of the improvement as possible and send by mail. An answer as to the prospect of a patent will be received, usually, by return of mail. It is sometimes best to have a search made at the Patent Office; such a measure often saves the cost of an application for a patent.

Preliminary Examination.

In order to have such search, make out a written description of the invention, in your own words, and a pencil, or pen and ink, sketch. Send these, with the fee of \$5, by mail, addressed to MUNN & Co., 37 Park Row, and in due time you will receive an acknowledgment thereof, followed by a written report in regard to the patentability of your improvement. This special search is made with great care, among the models and patents at Washington, to ascertain whether the improvement presented is patentable.

Reissues.

A reissue is granted to the original patentee, his heirs, or the assignees of the entire interest, when, by reason of an insufficient or defective specification, the original patent is invalid, provided the error has arisen from inadvertence, accident, or mistake, without any fraudulent or deceptive intention.

A patentee may, at his option, have in his reissue a separate patent for each distinct part of the invention comprehended in his original application by paying the required fee in each case, and complying with the other requirements of the law, as in original applications. Address MUNN & Co., 37 Park Row, New York, for full particulars.

Caveats.

Persons desiring to file a caveat can have the papers prepared in the shortest time, by sending a sketch and description of the invention. The Government fee for a caveat is \$10. A pamphlet of advice regarding applications for patents and caveats is furnished gratis, on application by mail. Address MUNN & Co. 37 Park Row, New York.

Design Patents.

Foreign designers and manufacturers, who send goods to this country, may secure patents here upon their new patterns, and thus prevent others from fabricating or selling the same goods in this market.

A patent for a design may be granted to any person, whether citizen or alien, for any new and original design for a manufacture, bust, statue, alto relievo, or bas relief, any new and original design for the printing of wools, silk, cotton, or other fabrics, any new and original impression, ornament, pattern, print, or picture, to be printed, painted, cast, or otherwise placed on or worked into any article of manufacture.

Design patents are equally as important to citizens as to foreigners. For full particulars send for pamphlet to MUNN & Co., 37 Park Row, New York.

Rejected Cases.

Rejected cases, or defective papers, remodeled for parties who have made applications for themselves, or through other agents. Terms moderate. Address MUNN & Co., stating particulars.

Value of Extended Patents.

Did patentees realize the fact that their inventions are likely to be more productive of profit during the seven years of extension than the first full term for which their patents were granted, we think more would avail themselves of the extension privilege. Patents granted prior to 1851 may be extended for seven years, for the benefit of the inventor, or of his heirs in case of the decease of fomer, by due application to the Patent Office, ninety days before the termination of the patent. The extended time inures to the benefit of the inventor, the assignees under the first term having no rights under the extension except by special agreement. The Government fee for an extension is \$100, and it is necessary that good professional service be obtained to conduct the business before the Patent Office. Full information as to extensions may be had by addressing MUNN & Co., 37 Park Row, New York.

To Make an Application for a Patent

The applicant for a patent should furnish a model of his invention if susceptible of one, although sometimes it may be dispensed with; or, if the invention be a chemical production, he must furnish samples of the ingredients of which his composition consists. These should be securely packed, the inventor's name marked on them, and sent by express, prepaid. Small models, from a distance, can often be sent cheaper by mail. The safest way to remit money is by a draft, or postal order, on New York, payable to the order of MUNN & Co. Persons who live in remote parts of the country can usually purchase drafts from their merchants on their New York correspondents.

Trademarks.

Any person or firm domiciled in the United States, or any firm or corporation residing in any foreign country where similar privileges are extended to citizens of the United States, may register their designs and obtain protection. This is very important to manufacturers in this country, and equally so to foreigners. For full particulars address MUNN & Co., 37 Park Row, New York.

Canadian Patents.

On the first of September, 1872, the new patent law of Canada went into force, and patents are now granted to citizens of the United States on the same favorable terms as to citizens of the Dominion.

In order to apply for a patent in Canada, the applicant must furnish a model, specification and duplicate drawings, substantially the same as in applying for an American patent. The patent may be taken out either for five years (government fee \$20), or for ten years (government fee \$40) or for fifteen years (government fee \$60). The five and ten year patents may be extended to the term of fifteen years. The formalities for extension are simple and not expensive.

American inventions, even if already patented in this country, can be patented in Canada provided the American patent is not more than one year old.

All persons who desire to take out patents in Canada are requested to communicate with MUNN & Co., 37 Park

Row, New York, who will give prompt attention to the business and furnish full instruction.

Foreign Patents.

The population of Great Britain is 31,000,000; of France, 37,000,000; Belgium, 5,000,000; Austria, 36,000,000; Prussia, 40,000,000, and Russia, 70,000,000. Patents may be secured by American citizens in all of these countries.

Copies of Patents.

Persons desiring any patent issued from 1836 to November 26, 1867, can be supplied with official copies at a reasonable cost, the price depending upon the extent of drawings and length of specification.

Any patent issued since November 27, 1867, at which time the Patent Office commenced printing the drawing and specifications, may be had by remitting to this office \$1.

A copy of the claims of any patent issued since 1836 will be furnished for \$1.

When ordering copies, please to remit for the same as above, and state name of patentee, title of invention, and date of patent. Address MUNN & Co., Patent Solicitors 87 Park Row, New York.

MUNN & Co. will be happy to see inventors in person, at their office, or to advise them by letter. In all cases, they may expect an honest opinion. For such consultations, opinions, and advice, no charge is made. Write plain; do not use pencil or pale ink; be brief.

All business committed to our care, and all consultations, are kept secret and strictly confidential.

In all matters pertaining to patents, such as conducting interferences, procuring extensions, drawing assignments, examinations into the validity of patents, etc., special care and attention is given. For information and for pamphlets of instruction and advice

MUNN & CO.,

PUBLISHERS SCIENTIFIC AMERICAN, 37 Park Row, New York.

OFFICE IN WASHINGTON—Corner F and 7th Streets, opposite Patent Office.

Advertisements.

RATES OF ADVERTISING.

Back Page - - - - - \$1.00 a line. Inside Page - - - - - 75 cents a line.

Engravings may head advertisements at the same rate per line, by measurement, as the letter-press.

HAND SAW MILL—Saves the labor of 3 men. S. C. HILLS, 51 Courtlandt St., New York.

Proposals For Contracts

OFFICE OF THE BOARD OF WATER COMMISSIONERS OF THE CITY OF YONKERS.

YONKERS, August 1, 1873.

Sealed proposals will be received by the Board of Water Commissioners of the City of Yonkers for entering into contracts for furnishing the following described work and materials, or any portion thereof:

- 10,000 feet 12-inch wrought iron and cement pipe. 15,000 feet 6-inch wrought iron and cement pipe. 5,000 feet 4-inch wrought iron and cement pipe. 10,000 feet 12-inch cast iron pipe. 15,000 feet 6-inch cast iron pipe. 75 feet 12-inch curved iron pipe. 100 feet 6-inch curved iron pipe. 50 feet 4-inch curved iron pipe. 60 hydrant pipe elbows. 125 Branches, 3 and 4 way, 4, 6 and 12 inches. 30 sleeves for 12 inch pipes. 40 sleeves for 6-inch pipes. 20 sleeves for 4-inch pipes. 8 1/2 inch stopcocks. 16 1/2 inch stopcocks. 16 1/4 inch stopcocks. 60 fire hydrants.

Also proposals for trenching for laying the cast iron pipes. Also proposals for laying the cast iron pipes.

Plans and specifications for the above named work and materials can be seen at the office of the City Clerk of the City of Yonkers.

All proposals must be enclosed in sealed envelopes, addressed to "The Board of Water Commissioners of the City of Yonkers," and endorsed "Proposals for Contract." They must contain the names of the sureties who will become guarantors of the faithful performance of any contract that may be awarded.

All proposals must be filed with William H. Doty, Clerk, at the office of the Clerk of the City of Yonkers, Manor Hall, on or before Monday, August 25, 1873.

The Board of Water Commissioners will meet at the office of the Clerk of the City of Yonkers, in Manor Hall, on Monday evening, August 25, 1873, at eight o'clock, to receive and open such proposals.

The Board of Water Commissioners reserve the right to accept or reject any or all such proposals, and also to increase or diminish the quantity of work and material at their discretion.

By order of the Board of Water Commissioners, STEPHEN BARKER, President. WM. H. DOTY, Clerk.

Claverack College and Hudson River Institute For both sexes; fine grounds; 187 furnished rooms; 20 instructors; 11 departments; 120 classical pupils; large gymnasium and drill hall. Special advantages in all departments. Term opens September 8. Rev. ALONZO FLACK, A. M., President, Claverack, N. Y.

\$50 TO \$150 PER WEEK guaranteed to intelligent and industrious persons, of either sex, to act as our Agents. Business very pleasant. Address THE WESTERN ART ASSOCIATION, Chicago, Ill.

GREEN'S PATENT STAVE JOINTER—Joints 150,000 Staves in a day. Address J. E. GREEN, Patentee, Saint Louis, Mo.

AGENTS—Most fortunate chance to make money, respectably and surely, \$25 to \$100 weekly, without fail. Article sells to every Lady and Gentleman. Address O. F. TEMPLETON, 615 Broadway, New York.

OTIS' SAFETY HOISTING Machinery. OTIS, BROS. & CO., NO. 348 BROADWAY, NEW YORK.

SHINGLE AND BARREL MACHINERY.—Improved Law's Patent Shingle and Heading Machine, simplest and best in use. Also, Shingle Heading and Stave Jointers, Stave Knotsizers, Heading Planers, Turners, &c. Address TREVOR & Co. Lockport, N. Y.

ROPER HOT AIR ENGINE COMPANY, 70 New Church St., New York

\$50 to \$200 per day! Agents wanted! All classes of working people, of either sex, young or old, make more money at work for us in their spare moments or all the time than anything else. Particulars free. Address G. Stinson & Co., Portland, Maine.

Great Secrets May be written on POSTAL CARDS, by my system of Cryptography. Combinations endless—each read only by its own key. Send for Circular. P. M., Greenfield, Ind.

Massachusetts Agricultural College, Founded and endowed by the State for the liberal education of the Industrial Classes, will begin its next academic year Aug. 27. For catalogue or information address President W. S. CLARK, Amherst, Mass.

\$125 A MONTH to Lady Agents. Address ELLIS MANUFACTURING CO., Waltham, Mass.

SELL YOUR PATENT.—The advertiser, who negotiates sales of valuable patents, wishes, at once, one or two really good Patented Inventions to sell. No advance charge made. Address P. O. Box "5,190," New York.

\$72.00 EACH WEEK.

Agents wanted everywhere. Business strictly legitimate. Particulars free. Address, J. WORRIN & Co., St. Louis, Mo.

MACHINERY, NEW AND 2d-HAND.—Send for Circular. CHAS. PLACE & CO., 60 Vesey St., New York.

WENDELL'S PATENT DOOR STOP. 1000 AGENTS WANTED. \$5 per day. Samples, 25 Cts. Wendell & Francis, 435 Walnut St., Phila.

NEW YORK STEAM ENGINE CO. MANUFACTURERS OF Machinists Tools OF ALL DESCRIPTIONS, 98 Chambers St. NEW YORK.

E. M. MAYO'S PATENT BOLT CUTTER. Send for Illustrated Circular, Cincinnati, Ohio.

AMENIA SEMINARY, AMENIA, N. Y.—A Family Boarding-School. On the Harlem Railroad, eighty-five miles from New York. Full courses of seminary instruction, with preparation for college or business. Personal care in study, habits, and health. Terms, \$360 per year. Fortieth year begins Sept. 15. S. T. FROST, A. M.

WOODBURY'S PATENT Planing and Matching and Molding Machines, Gray & Wood's Planers, Self-oiling Saw Arbors, and other wood working machinery. S. WOODS, 167 Liberty Street, N. Y.; Send for Circulars. 187 Sudbury street, Boston.

PAGE'S Water Flame Coal Lime Kiln, with coal or wood. No. 1 Soft White Lime or Cement, with use of water. C. D. PAGE, Patentee, Rochester, N. Y.

TO INVENTORS AND MANUFACTURERS The Managers of the 42d Exhibition of the American Institute, of the City of New York, beg to announce, that the Exhibition Buildings on 2d and 3d Avenues and 63d and 64th Streets, will be open for the reception of heavy Machinery August 18th and for other articles, September 1st 1873. The Exhibition will be formally opened September 10th. For particulars, address "General Superintendent, American Institute, New York."

BOULT'S PATENT Single Spindle Combined Moulding, Paneling, & Dove-tailing Machine. For Carving, Paneling, and Irregular Moulding, various kinds of Dove-tailing and Routing. The simplest and most useful Machine for Furniture, House-fitting, Cars, Organs, Drawers, Brackets, &c., &c. BATTLE CREEK MACHINERY COMPANY, MANUFACTURERS, Battle Creek, Michigan.

GLASS & MOULDS for Fruit Jars, Patent Lamps, Bottles, etc., made by H. BROOKE, 14 years at White and Centre Streets, New York. The shortest and cheapest way order direct of Mould Maker. PARTICULAR ATTENTION PAID TO MOULDS FOR INVENTORS.

TO FOUNDRIES, Factories, Ropewalks, &c.—For sale or lease, blocks of Lots with bulkhead waterfront. Low prices, easy terms. S. B. SCHIEFFELIN, 15 East 26th Street, New York.

HARTFORD Steam Boiler INSPECTION & INSURANCE CO. CAPITAL \$500,000. ISSUES POLICIES OF INSURANCE, after a careful inspection of the Boilers, covering all loss or damage to Boilers, Buildings, and Machinery, ARISING FROM—STEAM BOILER EXPLOSIONS.

The business of the Company includes all kinds of STEAM BOILERS, STATIONARY, MARINE, & LOCOMOTIVE.

Full information concerning the plan of the Company's operations can be obtained at the HOME OFFICE, in Hartford, Conn., or at any Agency.

J. M. ALLEN, President. C. M. BEACH, Vice Pres J. B. PIERCE, Secretary.

BOARD OF DIRECTORS: J. M. Allen, President. Lucius J. Hendee, President. John A. Butler, Pres. Conn. River Banking Co. Charles M. Beach, of Beach & Co. Daniel Phillips, of Adams Express Co. G. M. Bartholomew, Pres't American National Bank. R. W. H. Jarvis, Pres't Colt's Fire-Arms Mfg. Co. E. M. Reed, Sup't Hartford & N. Haven Railroad. Hon. Chas. M. Pond, Tres. State of Connecticut. T. O. Enders, Sec. Atna Life Ins. Co. Leverett Brainard, of Case, Lockwood & Co. GEN. WM. B. FRANKLIN, Vice Pres't Colt's Pat. Fire-Arms Man'g Co. Austin Dunham, Pres. Willimantic Linen Co. Geo. Crompton, Crompton Loom Works, Worcester. Earl P. Mason, Pres't Prov. & Wor. R. R. Providence. Wm. Adamson, of Baeder, Adamson & Co., Philadelphia. New York Office, 239 Broadway. THEO. H. BASCOCK, Manager. R. K. MCMURRAY, Inspector.

IMPROVED FOOT LATHES. SELLING Everywhere. N. H. BALDWIN, Laconia, N. H.

WOODWARD'S NATIONAL ARCHITECT 1000 WORKING DRAWINGS. Plans, Details, Specifications & Estimates. TWELVE DOLLARS, post-paid.

MONCKTON'S NATIONAL STAIRBUILDER, Six Dollars, post paid. MONCKTON'S NATIONAL CARPENTER & JOINER, Six Dollars, post Framing and Roofing, paid.

ORANGE JUDD & CO., 245 Broadway, New York. 12 Samples sent by mail for 50 cts., that retail quick for \$10. R. L. WOLCOTT, 181 Chatham Square, New York.

Machinery, Wood and Iron Working of every kind. Leather and Rubber Belting, Emery Wheels, Babbit Metal, &c. GEO. PLACE & CO., 121 Chambers St., N. Y.

Cold Rolled Shafting. Best and most perfect Shafting ever made, constantly on hand in large quantities, furnished in any lengths up to 24 ft. Also, Pat. Coupling and Self-oiling adjustable Hangers. GEORGE PLACE & CO., 121 Chambers Street, New York.

Sturtevant Blowers. Of every size and description, constantly on hand. GEORGE PLACE & CO., 121 Chambers Street, New York.

PATENT PUNCHING SHEARING MACHINES. With all Modern Improvements, in forms adapted to every kind of work. WARRANTED SUPERIOR TO ALL OTHERS. Presses adapted to all kinds of work in store ready for shipment. MOSES G. WILDER, 121 Chambers St., New York.

Farrel's Patent Railway Crane, Patent Ground Chilled Rolls, ROLLING MILLS AND MILL MACHINERY. Punches and Shears for heavy work—Fly Wheels, Shafts, Gears, Pulleys, and Special Castings, at Low Prices. FARREL FOUNDRY & MACHINE CO., MOSES G. WILDER, SELLING AGENT, 121 Chambers Street, New York.

COWELL PATENT DOOR AND GATE SPRING, worth ten of all others. Won't corrode or break. Ask the Hardware dealers for it, or address Sole Manufacturer, JAS. H. WHITE, Newark N. J. Territory for Sale.

PATENT COLD ROLLED SHAFTING. The fact that this shafting has 75 per cent greater strength, a finer finish, and is truer to gauge, than any other in use, renders it undoubtedly the most economical. We are also the sole manufacturers of the CALVERT PAT. COLLARS PAT. COUPLING, and furnish Pulleys, Hangers, etc. of the most approved styles. Price lists mailed on application to Try street, 2d and 3d avenues, Pittsburgh, Pa. 190 S. Canal St., Chicago. FULLER, DANA & FITZ, Boston, Mass. GEO. PLACE & CO., 121 Chambers street, N. Y. PIERCE & WHALING, Milwaukee, Wis.

A POPULAR IDEA. We have been furnishing the new, large illustrated paper, entitled "Cricket on the Hearth," at one dollar a year to subscribers on a guarantee that the money will be refunded any time within three months if not satisfactory. We have not been asked to return a dollar yet. 100,000 already sold. Sixteen large pages. The best and cheapest paper in the world. A \$5 chromo to every subscriber. 25c. for three months trial. Agents wanted \$25. for the paper three months, and terms. JONES & HADLEY, Publishers, 176 Broadway, New York.

STENCIL DIES For cutting business Stencils, all sizes. Also complete outfits for Clothing Stencils and Key Checks, with which young men are making from \$5 to \$30 a day. Send for catalogue and samples to S. M. SPENCER, 117 Hanover St., Boston, Mass.

U. S. PIANO CO., 810 Broadway, N. Y.

RICHARDSON, MERIAM & CO. Manufacturers of the latest improved Patent Danes and Woodward Planing Machines, Matching, Sash and Molding, Tenoning, Mortising, Planing, Shaping, Vertical, and Circular Re-sawing Machines, Saw Mills, Saw Arbors, Scroll Saws, Railways, Cut-off, and Rip-saw Machines, Spoke and Wood Turning Lathes, and various other kinds of Wood-working Machinery. Catalogues and price lists sent on application. Manufacturing Worcester, Mass. Warehouse, 107 Liberty St., New York. 17

FOR SALE—The right to manufacture and sell the Patent Stave Grain Baskets in the States of Ohio, Pennsylvania, and New York. Said Baskets protected by numerous patents issued to Horace C. Jones and others. G. I. BREWSTER, Appleton, Wis.

WROUGHT IRON BEAMS & GIRDERS THE Union Iron Mills, Pittsburgh, Pa. The attention of Engineers and Architects is called to our improved Wrought-iron Beams and Girders (patented), in which the compound welds between the stem and flanges, which have proved so objectionable in the old mode of manufacturing, are entirely avoided, we are prepared to furnish all sizes at terms as favorable as can be obtained elsewhere. For descriptive lithograph address Carnegie, Kloman & Co., Union Iron Mills, Pittsburgh, Pa.

Niagara Steam Pump. CHAS. B. HARDICK, 23 Adams St., Brooklyn, N. Y.

PUNCHING AND DROP PRESSES. For the Best and Cheapest Address THE STILES & PARKER PRESS CO., MIDDLETOWN, CONN.

NEW & IMPROVED PATTERNS.—MACHINISTS' TOOLS—all sizes—at low prices. E. GOULD, 97 to 118 N. J. R. R. Ave., Newark, N. J.

WOODWORKING MACHINERY GENERALLY. Specialties, Woodward Planers and Richardson's Patent Improved Tenon Machines. Central, corner Union St., Worcester, Mass. WITHERBYRUGG & RICHARDSON.

Steam ENGINES, Boilers, ETC.,

Of all the best styles and makers, at a discount of THIRTY-FIVE PER CENT from Manufacturers' lowest prices. Write for circular and advice before purchasing. E. K. ROBERTS, 52 Broadway, New York

Andrew's Patents. Noiseless, Friction Grooved, or Geared Hoisters, suited to every want. Safety Store Elevators. Prevent Accident, Rope, Belt, and Engine break. Smek's Patent Safety Boilers. Oscillating Engines, Double and Single, 1-2 to 100-Horse power. Centrifugal Pumps, 100 to 100,000 Gallons per Minute. Best Pumps in the World, pass Mud, Sand, Gravel, Coal, Grain, etc., without Injury. Simple, Durable, and Economical. Send for Circulars. WM. D. ANDREWS & BRO., 414 Water Street, New York.

Patent Woodwork, Daniels and Dimension Planers, Moulding, Mortising, Tenoning and a great variety of other Machinery for Working in Wood. Sole Manufacturer of the celebrated Farmer Patent Matcher Heads and Antiriction Cutters and the New England Band Saw. Factory 26 Salisbury St., Worcester, Mass. Sales-room 121 Chambers & 103 Reade Sts., N. Y. R. BALL & CO.

GEAR'S PATENT VARIETY MOULDING MACHINE. The only simple, complete and reliable Upright Shaping Machine known. Legality of Patents sustained in United States Circuit Courts. Infringers who do not make immediate settlements will be prosecuted. I MEAN BUSINESS. A. S. GEAR, Sole Manufacturer & Proprietor. Also Manufacturer and Dealer in all kinds of Machinery and Mechanical Supplies. 56 Sudbury St., Boston, Mass.

1832. SCHENCK'S PATENT. 1871. WOODWORTH PLANERS. And Re-sawing Machines, Wood and Iron Working Machinery, Engines, Boilers, etc. JOHN B. SCHENCK'S SONS, Mattawan, N. Y., and 118 Liberty St., New York.

CIVIL AND MECHANICAL ENGINEERING at the Rensselaer Polytechnic Institute, Troy, N. Y.—Instruction very practical. Advantages unsurpassed in this country. Graduates obtain excellent positions. Re-opens Sept. 17th. For the Annual Register, containing improved Course of Study, and full particulars address Prof. CHARLES DRÖWNE, Director.

THE "PHILADELPHIA" HYDRAULIC JACK. PISTON guided from both ends; all working parts guarded from dust; single or double pumps, cylinders, shafts, rockers, arms, pistons, etc., entirely steel. No. 14 N. 5th St., Philadelphia. PHILIP S. JUSTICE, No. 42 Cliff St., New York.

GREAT REDUCTION IN PRICES OF LE COUNT'S PATENT HOLLOW LATHE DOGS, and his Machinist Clamps of both Iron and Steel. 1 set of 8 dogs, from 3/4 to 2 inch, \$6.50.

His expanding Mandril is a first class tool which has long been needed by every Machinist. Send for latest circular. W. LE COUNT, South Norwalk, Conn.

PORTABLE STEAM ENGINES, COMBINING the maximum of efficiency, durability and economy, with the minimum of weight and price. They are widely and favorably known, more than 1,000 being in use. All warranted satisfactory or no sale. Descriptive circulars sent on application. Address THE J. C. HADLEY CO., Lawrence, Mass. Liberty St., New York.

MASON'S PAT' FRICTION CLUTCHES are manufactured by Volney W. Mason & Co., Providence, R. I. Agents, L. B. BROOKS, 80 Cliff street, New York; TAPLIN, RICE & CO., Akron, Ohio.

MACHINERY FOR PRINTING OIL Cloth, Paper and Cotton. The Patent (No. 106,334) for Sale. Address J. KRANTZ, 17 Gates Av., Brooklyn, N. Y.

An deutsche Erfinder. Diese große und thätige Classe unsrer Bevölkerung machen wir besonders darauf aufmerksam, daß unsre Firma durch ihre Verbindung mit Washington und den europäischen Hauptstädten, besondere Vortheile zur Erlangung von in- und ausländischen Patenten bietet.

Jeder Erfinder, gleichviel welcher Nationalität angehörig, ist durch die liberalen Patentgesetze der Vereinigten Staaten zum Patentschutz für Erfindungen berechtigt. Unsere Firma ist bereit, gefügt auf 26-jährige Erfahrung, deutsche Erfinder jeder Zeit zu berathen und zu mäßigen Preisen rasch und pünktlich Patente zu erlangen.

Die Deutsche Section ist in den Händen fähiger deutscher Ingenieure, welche in der Office persönlich mit Erfindern verkehren werden.

Der „Scientific American“ wird in seinen Spalten die bedeutendsten Erfindungen besprechen.

Correspondenz erbeten und prompt beantwortet. Pamphlete in deutscher Sprache werden auf Verlangen franco zugesandt.

Adresse: Munn & Co., „Scientific American“ Patent Agentur, 37 Park Row, New York City.

Advertisements

Advertisements will be admitted on this page at the rate of \$1.00 per line for each insertion.

The value of the SCIENTIFIC AMERICAN as an advertising medium cannot be over-estimated. Its circulation is ten times greater than that of any similar journal now published.

Howard & Co., No. 222 Fifth Av., New York, FURNISH INFORMATION FREE IN REGARD TO

Waltham Watches

Thousands of persons at this present time, in different parts of the country, desire to purchase watches, and each wants a good one.

Single watches will be sent by express, with bill to collect on delivery, to any part of the country, no matter how remote and with privilege to examine before paying.

N. Y. Safety Steam Power Co., 30 CORTLANDT STREET, NEW YORK.

Superior STEAM ENGINES and BOILERS, by special machinery and duplication of parts. They are safe, economical, easily managed and not liable to derangement.

PATTERNS & TOOLS FOR SALE

The Burdon Iron Works (Hubbard & Whitaker) offer for sale their large stock of valuable patterns, including all kinds of Engines and Pumps, Pulley, Fly, Band, Gear and Worm Wheels, Sugar Mills, Friction Calendar, Friction Clutch and Friction Wheels; Screw, Lever, Drop and Hydraulic Presses; Boiler Heads, Drum Heads, Boiler Fronts, Ash Pans, Grate Bars and Circular Grates; Pillow Blocks, Hangers and Boxes. Also a lot of Lathes, Drills, Planers, Shapers, and Boiler Makers' Tools.

NILESTOOL WORKS, HAMILTON, OHIO.

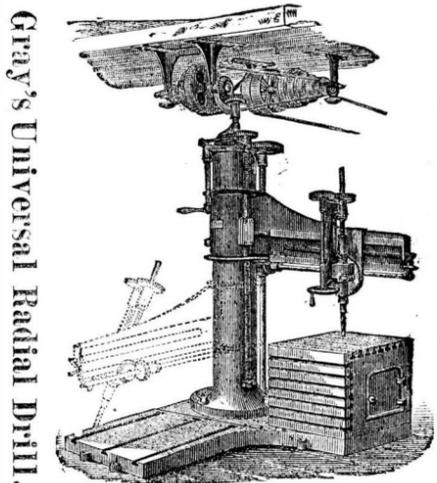

NOYE'S MILL FURNISHING WORKS are the largest in the United States. They make Burr Millstones, Portable Mills, Saut Machines, Packers, Mill Picks, Water Wheels, Pulleys and Gearing, specially adapted to flour mills.

RIVERVIEW ACADEMY, Poughkeepsie, N.Y.

NUMEROUS TESTS HAVE PROVED N.F. BURNHAM'S NEW TURBINE WATER WHEEL TO BE THE BEST EVER INVENTED.

WHALEN TURBINE. No risks to purchaser. Pamphlet sent free. SETH WHALEN, Balistion Spu, N. Y.

Pass This By If you are a fool or a lunatic; but if you are sane, and wish to make money, (man or woman,) get a postal card now and send your address.

BUERK'S WATCHMAN'S TIME DETECTOR.—Important for all large Corporations and Manufacturing concerns—capable of controlling with the utmost accuracy the motion of a watchman or patrolman, as the same reaches different stations of his beat.

N. B.—This detector is covered by two U. S. Patents. Parties using or selling these instruments without authority from me will be dealt with according to law.

PRICE REDUCED.

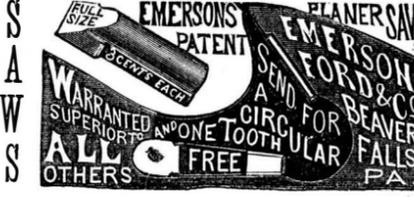

THE AMERICAN Turbine Water Wheel Has recently been improved and subjected to thorough tests by James Emerson, Holyoke, Mass., showing higher average results than any Turbine Wheel ever known.

WIRE ROPE.

JOHN A. ROEBLING'S SONS MANUFACTURERS, TRENTON, N. J. FOR Inclined Planes, Standing Ship Rigging, Bridges, Ferriss, Stays, or Guys on Derricks and Cranes.

Machinist's Tools, EXTRA HEAVY AND IMPROVED. LUCIUS W. POND, MANUFACTURER Worcester, Mass.

SCHLENKER'S PATENT BOLT CUTTER NEW INVENTION. ADDRESS, HOWARD IRON WORKS, BUFFALO, N. Y.

RANSOM SYPHON CONDENSER perfects and maintains vacuum on Steam Engines at cost of one per cent its value, and by its use Vacuum Pans are run with full vacuum without Air Pump.



CHAMPION SPRING MATTRESS—The latest and best improvement. Do you want a healthy and comfortable bed? Here it is. The softest, easiest, cheapest, most popular, and durable Spring Bed in market.

THE SCIENCE RECORD FOR 1873.

A Compendium of the Scientific Progress and Discoveries of the Preceding Year. Illustrated with over 150 Engravings. 600 pages, octavo. Price, \$2.

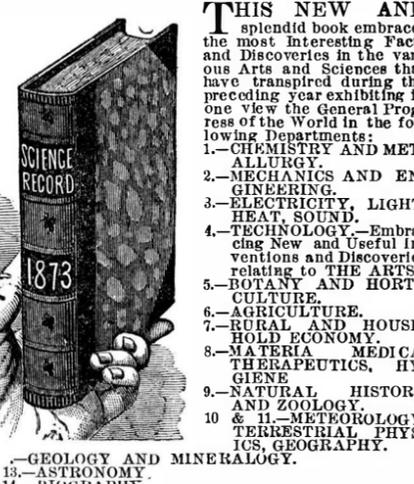

Every person who desires to be well informed concerning the Progress of the Arts and Sciences should have a copy of SCIENCE RECORD FOR 1873. It is a most interesting and valuable book, and should have a place in every Household, in every Library.

MUNN & CO., PUBLISHERS, 37 Park Row, New York City. The SCIENTIFIC AMERICAN will be sent one year and one copy of SCIENCE RECORD FOR 1873, on receipt of \$4.50.

SCIENCE RECORD FOR 1872, uniform with the above, Price \$2. Library binding, \$2.50.

LUBRICATORS.

DREYFUS' transparent Self-acting Oilers, for all sorts of Machinery and Shafting, are reliable in all seasons, saving 75-85 per cent.

SUPER-HEATERS Save fuel, and supply DRY steam. Easily attached to any boiler. HENRY W. BULKLEY, Engineer, 98 Liberty St., New York.

Pyrometers. For testing Ovens, Boiler flues, Blast furnaces, Super-Heated Steam, Oil Stills, &c. Address HENRY W. BULKLEY, 98 Liberty St., New York.

BEACH'S Scroll Sawing Machines.—Cheapest and best in use. For Illustrated Catalogue and Price List, send to H. L. BEACH, 90 Fulton St., N. Y.

Working Models And Experimental Machinery, Metal, or Wood, made to order by J. F. WELCHER, 62 Center st., N. Y.

LEFFEL'S IMPROVED DOUBLE TURBINE WATER WHEEL New Book Just Out—160 PAGES SENT FREE

To any parties interested in water power, address JAMES LEFFEL & CO., SPRINGFIELD, OHIO, or 109 LIBERTY ST., N. Y. CITY.

KIDDER'S PASTILES—A Sure Relief for Asthma. STOWELL & CO. Charlestown, Mass. IRON STEAMSHIP BUILDERS. NEAFIE & LEVY, PENN WORKS, MARINE ENGINES, BOILERS, AND BUILDERS OF COMPOUND ENGINES, PHILADELPHIA, PA.

PORTLAND CEMENT, From the best London Manufacturers. For sale by JAMES BRAND, 55 Cliff St., N. Y. A Practical Treatise on Cement furnished for 25 cents

IRON PLANERS, ENGINE LATHES Drills, and other Machinists' Tools, of superior quality, on hand, and finishing. For sale low. For Description and Price address NEW HAVEN MANUFACTURING CO. New Haven, Conn.

THE HASKINS MACHINE CO. FITCHBURG, MASS., Manufacturers of PATENT VERTICAL STEAM ENGINES.

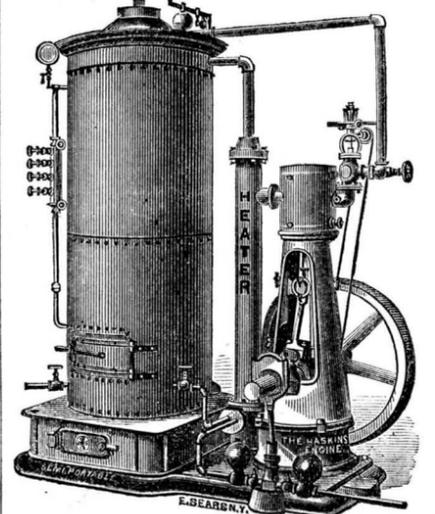

Our Combined Engine and Boiler are made in quantities and to standard gauges, that all parts are interchangeable. Can be run with greater safety and less expense than any other engine manufactured.

MORRIS, TASKER & CO., MANUFACTURERS OF AMERICAN CHARCOAL IRON Boiler Tubes. WROUGHT-IRON TUBES AND FITTINGS, FOR GAS, STEAM WATER, AND OIL.

EVERY VARIETY STEAM PUMPS. SEND FOR ILLUSTRATED CATALOGUE GOPE & MAXWELL MFG. CO. HAMILTON, OHIO.

MONEY made with Stencil and Key Check outfits. The cheapest and best. Catalogue and samples free. E. M. DOUGLASS, Brattleboro', Vt.

THE HEALD & SISCO Patent Centrifugal Pumps, VERTICAL & HORIZONTAL. First Premiums at New Orleans, Cincinnati, and New York.

Perfect satisfaction guaranteed. The cheapest, most durable, popular and successful Pump known, for Paper Makers, Tanners, Contractors, Brick Makers, Distillers, etc.

AGENTS WANTED—Anybody can make it pay. First class articles for Office and Household use. Manufacturer's prices, and enormous profits Address, for circular, JAS. H. WHITE, Newark, N. J.

T. V. Carpenter, Advertising Agent. Address Box 773, New York city.



THREE PLY ROOFING, In Use Ten Years. A good article, well recommended, and suitable for either steep or flat roofs. Send for Circular and Samples. MICA ROOFING Co., 73 Maiden Lane, New York.

SILICATE OF SODA. HODGES, COOLIDGE & CO., BOSTON, MASS.

THE LATEST IMPROVEMENT IN LUBRICATORS This NEEDLE-VALVE OIL FEEDER for Locomotive and Stationary Engines has met with great success.

MAHOGANY, ROSEWOOD, WALNUT, WHITE HOLLY SATIN WOOD HUNGARIAN ASH, AND ALL KINDS OF WOODS. IN LOGS, PLANK, BOARDS, AND VENEERS.

GEO. W. READ & CO., Mill and Yard, 186 to 200 Lewis St., cor. 6th St., E. R., N. Y. Orders by mail promptly and faithfully executed.

DOUBLE ACTING BUCKET-PLUNGER Steam Pumps ALWAYS RELIABLE. VALLEY MACHINE COMPANY, Easthampton, Mass.

EMERY WHEEL MACHINERY for grinding Tools and Metals, gumming Saws, cleaning Castings, grinding Planer Knives perfectly straight.

The Pulsometer or Magic Pump. The simplest, most durable and effective steam pump now in use.

C. HENRY HALL & CO., 20 Cortlandt Street, New York City.

AMERICAN SAW CO., No. 1 Ferry St., New York.

Movable-Toothed Circular Saws, PERFORATED CROSS-CUT, AND SOLID SAWS. ALSO, IVENS & BROOKES PATENT Eccentric-Geared Power Press.

P. BLAISDELL & CO., MANUFACTURERS OF THE BEST Patent Drill Presses, with Quick Return Motion, In the Market, also other Machinist Tools.

BUILDERS SEND FOR BOOK CATALOGUE. BICKNELL, 27 Warren St., N. Y.

HOUSTON'S PATENT TURBINE WATER WHEEL Simplest, Strongest, Cheapest, Best. In the test at Holyoke, in 1872, the Houston gave the highest percentage ever shown in a reliable test.

THE STANDARD MAKE! Emery Wheels and Emery Grinding Machinery. THE TANITE CO., Stroudsburg, Pa.

SCIENTIFIC AMERICAN

TERMS. One copy, one year \$3.00 One copy, six months 1.50 One copy, four months 1.00

One copy of Scientific American for one year, and one copy of engraving, "Men of Progress" - 10.00 One copy of Scientific American for one year, and one copy of "Science Record," for 1873 - 4.59

MUNN & CO., 37 PARK ROW NEW YORK

THE "Scientific American" is printed with CHAS. ENEU JOHNSON & CO.'S INK, Tenth and Lombard sts., Philadelphia and 59 Gold st., New York.