

PATENT HEMMER.

Those of our readers who have followed the course of improvements in the sewing machine are aware that it does not sew "over and over," and that the only way in which hemming can be done by it is by folding the cloth over at the edge, so as to roll the edge completely into the fold, and then fasten the fold down by sewing along it with the "through and through" stitch. Many devices have been planned for folding the hem, but, so far as we are aware, they all turn the fold on the upper edge of the cloth, and consequently when they are used with a machine which forms a loop stitch, as Grover & Baker's, for instance, the wrong side of the stitch comes on the right side of the hem. The hemmer which we here illustrate will turn the fold either on the upper or under side of the cloth, and thus obviates the important objections which we have mentioned.

Figs. 1 and 2 show the arrangement for turning the hem on the upper side of the cloth; the frame, A, with the tongue, b, which is attached to it, being removable, and the folder, C, being capable of being turned with the opposite side up. The manner in which the cloth is wrapped around the tongue and into the turns of the folder, is clearly shown in Fig. 2. The hemmer is attached to the sewing machine by screws passing through the slot, D, in such position that the needle will pass through the cloth at E, just after it leaves the folder. It will be seen that the distance of the seam from the edge of the cloth may be adjusted by sliding the folder in its case, and by slipping the slot, D, beneath the screws which hold it.

For folding the hem on the lower side of the cloth, the frame, A', shown in Figs. 3 and 4, is used, and the folder, C', is turned over. This arrangement brings the right side of the stitch in loop-stitch machines on the right side of the hem.

This hem-folder may be used in hemming by hand, or it may be attached to any variety of sewing machine.

The patent for this invention was obtained, through the Scientific American Patent Agency, Oct. 18, 1859, and persons desiring further information in relation to it will please address the inventor, Leverett Clark, at Monticello, N. Y.

LIABILITIES OF COMPANIES FOR ACCIDENTS.

Mortimer Lee vs. the New York Gas and Steamboat Gas Company.—This case was brought by the plaintiff to recover damages from the defendants for injuries received while in the defendants' factory. The defendants are manufacturers of gas cylinders for the use of steamboats and cars, at No. 8 Gold-street, this city. These cylinders are made to be filled with gas, compressed to a pressure of 200 or 300 lbs. to the inch, so that the gas taken therefrom would burn so long as any pressure above that of the atmosphere continued. The company had, up to July 13, 1858 (when the accident occurred) manufactured and put into successful operation many cylinders, the proportions of which were ten inches in diameter and six feet in length. These were tested at the factory by hydrostatic pressure (the air pump), and not one of them burst. A short time before the accident, the company caused a cylinder to be constructed, four feet long and eighteen inches in diameter, by way of experiment, as a short cylinder of equal internal capacity would be more convenient in cars, &c., than a long one.

This cylinder was tested, as usual, at the factory by the air pump. After the pressure had run up to 344 lbs., as indicated by the gages, the person in charge of the experiment left it and went into the office without, as is alleged, leaving any one in charge of the pump, or to observe the amount of pressure, or whether the cylinder yielded. The plaintiff and six other workmen were employed in different parts of the shop at the time. While the cylinder was thus left, it burst with great noise and violence; a workman, named Sharp, was instantly killed, and the plaintiff's right leg was so badly burnt, that amputation was necessary. It is alleged that he is still unable to work at his trade, and has not yet earned anything since the injury. The plaintiff claims \$20,000 damages, on the ground that the defendants' negligence

and recklessness caused the explosion. The defense is a denial of the statements in the complaint, and asserts that the explosion was caused by the negligence of a fellow servant; that the plaintiff had left his place of business where he should have been at work, and seated himself on the cylinder, and was so seated when it exploded; that the explosion was an inevitable accident, not caused by any negligence of the defendants. The jury rendered a verdict of \$6,000 for the plaintiff.

SAVING NITRATE OF SILVER.

Ninety-eight per cent of the nitrate of silver employed by the most experienced photographers to sensitize their plates or their paper, is carried away into the fixing and washing baths, in other terms, on a sum of one hundred shillings expended, or converted into nitrate, about five shillings only are utilized in the production of the photo-

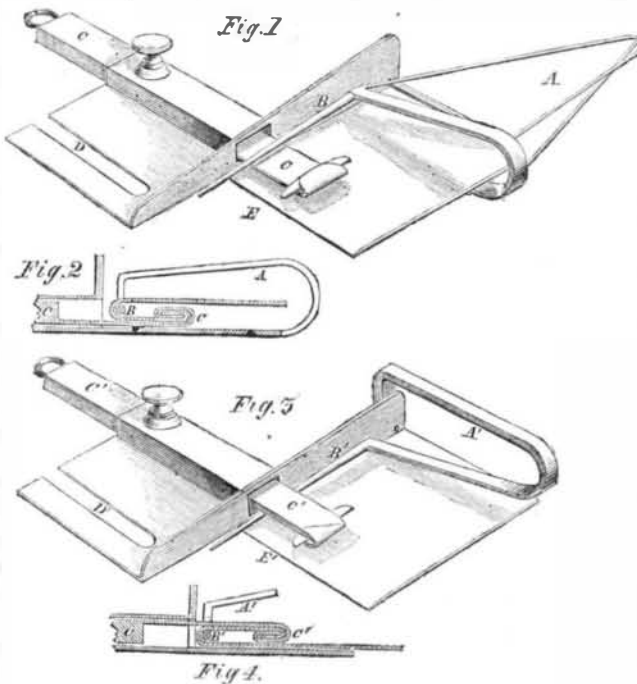

CLARK'S PATENT HEMMER.

graphic image. These figures give us an idea of the immense loss any photographer must sustain if the contents of the fixing and washing baths are not turned to account in one way or another. Then comes the question, which is the most economical and effective manner of extracting from these baths the silver they contain? I do not know how you operate this in England, but in France the liquid residues are carefully collected in appropriate glass jars, and the silver they contain precipitated, without any previous operation, by sulphide of potassium. The precipitate, which is principally formed of sulphide of silver, contains, also, sulphur organic matter, &c.; it is collected either upon a filter or by decantation, and then dried. It is afterwards calcined in a crucible with nitrate of potash. The result of this calcination is a melted lump of pure silver. It is curious enough that in this case a reduction takes place by means of a powerful oxidizing agent. The nitrate of potash employed, however, plays here, as everywhere, the part of a powerful oxidizer; its oxygen is given to the sulphur of the sulphide of silver precipitated, to produce sulphuric acid, this unites with the potash of the saltpeter, forming sulphate of potash, whilst pure silver is put in liberty by the decomposition of the sulphide; at the same time, gases (oxyds of azote) are evolved from the decomposition of the saltpeter. Waste photographic paper, impregnated with salts of silver, may be carefully burned in wide, open crucibles, and their ashes collected. To these ashes must be added their own weight of a mixture of nitrate of potash and carbonate of soda, both dry; and this mixture may then be added to the sulphide of silver to be reduced, or heated separately.—*Paris Correspondent of the London Photographic News.*

[The French chemists pursue very refined chemical processes; and if there is one feature above another for which they deserve credit, it is that of economy in the arts—nothing is allowed to be lost. In the reduction of silver from the nitrate, at our Assay Office, a more simple method than the above is pursued. The nitrate

of silver formed in purifying the gold is reduced first by the chloride of soda, then by granulated zinc.—Eds.

LINSEED OIL AND OIL-CAKE.

Messrs. Editors:—A recent editorial suggests the following communication in reference to the manufacture of linseed oil. There is a great quantity of linseed oil made in Louisville, Ky., and the oil-cake left from this was, a few years ago, and probably is now, exported from this country to Liverpool in order to obtain a market, which, in this country, it has not. This cake is most excellent food for cattle, but it seems that our farmers are so dead to their own interests that they suffer it to be taken to England where its value is appreciated. Thus this country is robbed of its due. I cordially agree with all of your editorial on this subject, especially as to the importance of linseed oil manufacture in this country. E. T. C.

Philadelphia, Pa., April 2, 1860.

[Our farmers are also very blind, we think, to their own interests in regard to the cultivation of flax. We have to import a vast amount of flax seed annually from the East Indies, to make our oil for painting. No less than 153,205 bags have been imported since Jan. 1st, and 215,000 bags are now on their way in 23 vessels which have sailed from Calcutta and Bombay. The stock of linseed on hand is but limited at the present moment. We import both linseed and linseed oil in large quantities, and we might cultivate all our own seed and make all our own oil. A lot of 30,000 gallons of English linseed oil was lately sold in this city for Boston. It brought 57½ cents per gallon, being from a half to one cent more than city-made linseed. A more extensive use of flax in manufactures would tend to increase the product of home-grown linseed. It is the opinion of some merchants that the export of linseed oil-cake ought to be encouraged, upon the principle that all the products which can be exported tends to increase the wealth of the country. This is an intricate commercial question, regarding which there are a variety of opinions.—Eds.

THE MANUFACTURE OF MOSAICS.—A letter from Rome, in the *Rochester Democrat*, gives the following account of the manufacture of mosaics at the Vatican factory:—"The mosaic copies of celebrated pictures, which are now almost the only ones which adorn the interior of St. Peter's, are the product of this manufactory, and are far superior to the ancient mosaics. The ancients, besides their inferiority in painting, show no such delicacy of shading, or such variety of coloring as has been attained in modern times. The material used for these mosaics is an artificial stone, of which 20,000 different shades are used. No one but a real artist, however one might at first imagine, can excel in such work. It was interesting enough to see a workman with a picture of enormous size before him, working for hours in the selection and fitting of one little piece of stone into the mosaic which is to be its copy. The large mosaics, eighteen feet in height, which adorn St. Peter's, have some of them cost twenty-five years of the labor of several artists. It seems to me that, rather than undertake so endless and unproductive a task, I would be the slave of a silver mine—and yet the perfection of the work is wonderful. At a little distance it is impossible to tell it from an oil painting, and it is next to indestructible. The mosaics of the Roman churches still last, while the churches themselves have been changed in almost everything else except the solid walls."

PORTER'S STEAM GOVERNOR.—On page 36, Vol. XIV. (old series) of the *SCIENTIFIC AMERICAN*, we published an illustrated description of the above governor for steam engines, and its very original character soon afterwards attracted the attention of persons capable of estimating its value. Since then it has been extensively applied to engines; and in every case which has come to our knowledge, it has given satisfaction. On the advertisement page of this number, W. J. McAlpine, ex-Chief Engineer of the United States Navy—whose reputation stands very high—certifies, in a very flattering manner, to its good qualities, and in his opinion we are fully agreed.

WIARD'S ICE BOAT.—We have received, from a Russian company in St. Petersburg, a letter addressed to Mr. Wiard, the inventor of a steam ice sledge. As we do not know his post-office address, we are unable to forward him the letter. It is held subject to his order.