

served in tubes that are completely surrounded by hot water. The sticks may be carried to the work in this thawer. Never place the thawer over a fire, or try to heat the water while the dynamite is in it. For thawing on a large scale, a building heated with steam or water coil is good, provided primers, men, and tools are kept out.

AN ELECTROLYTIC RECTIFIER FOR CHARGING IGNITION BATTERIES.

BY FREDERICK E. WARD.

It is well known that small storage batteries, such as are used for automobile ignition, are very easily charged by connecting them to a direct-current house-lighting circuit through a suitable resistance, but where the current supply is alternating many have supposed that good results cannot be obtained without the use of complicated and expensive apparatus for converting the alternating into direct current. By following out the instructions given below, however, an electrolytic rectifier suitable for charging a six-volt sixty-ampere-hour battery from 110 volts can be made and used at home with small expense and satisfactory results.

There are two parts to the required apparatus—the autotransformer for reducing the voltage of the line from 110 to that required by the battery, and the electrolytic cell for rectifying the current or causing it to pass always in the same direction.

The autotransformer is shown by the drawings in Fig. 1. It consists of a single coil of magnet wire wound on a rectangular wooden spool, inside of which a bundle of steel strips is afterward placed to form a core. The spool is best made of well-seasoned white pine or whitewood, as these soft woods are readily obtained and easy to work. It is a good plan to dry the wood thoroughly in an oven before it is cut up.

For the body of the spool, four pieces 2 1/16 inches wide, 4 inches long, and not thicker than 1/4 inch are required. These should be securely glued and nailed together so as to form a rectangular tube 4 inches long and measuring 1 9/16 inch by 2 1/16 inches on

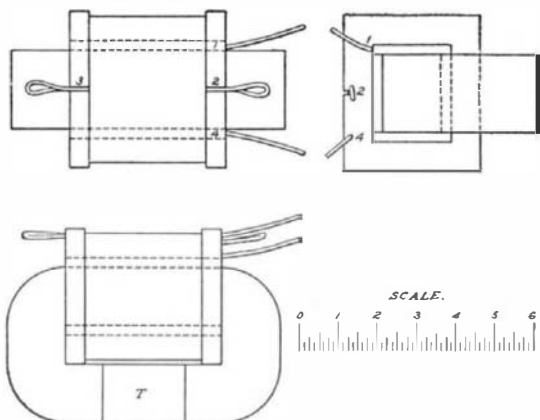

Fig. 1.—THE AUTOTransFORMER.

the inside. For the heads, two pieces 1/2 inch thick, 3 1/2 inches wide, and 4 inches long are needed. Through the middle of each a hole about 2 1/16 inches wide by 2 9/16 inches long should be cut to fit snugly over the ends of the tube. When the heads are securely glued to the central tube, and braced by a few wire nails driven into them from the inside, the whole will form a strong spool having a space 3 inches long between the heads for the winding. The corners of the tube where the wire is to be wound must be well rounded off with a file, to avoid the difficulty of having to bend the first layer of wire around square corners. In one of the heads two small holes and a saw cut must be made as shown at 1, 2, and 4 in Fig. 1, while in the other head only one saw cut, 3, is needed. These holes and slots are for bringing out ends and loops in the winding, so that connections may afterward be made to different parts of the latter. On the heads of the spool the numbers 1 to 4 should be plainly carved to avoid confusion.

The coil is to be wound of No. 16 double cotton-covered magnet wire, of which about three pounds, all in one piece, will be required. This is to be wound on the spool in eight layers of about fifty turns each, as follows: First pass about 4 inches of one end of the wire out through the hole numbered 1, and then wind on six even layers like thread on a spool. The work can be done most easily by clamping the spool on the face plate of a lathe and turning it over slowly by hand as the winding progresses. It is well to give each layer a coat of shellac before winding the next. When the six layers have been put on, make a short loop in the wire at saw cut marked No. 2, and allow the loop to project outside an inch or so, as shown. Continue the winding as before, and at the end of the seventh layer leave a similar loop at saw cut No. 3, and finally finish by putting on the last, or eighth, layer and passing the end of the wire out through hole No. 4. After the winding is complete it should be protected from possible injury by a covering of two or three layers of cloth fastened with glue or shellac.

The core is to be made of strips of thin sheet iron

or sheet steel cut two inches wide. One sixty-fourth inch is a desirable thickness, but anything less than 1/32 inch will answer. About eleven pounds will be needed for the core, in strips of different lengths varying all the way from 11 up to 21 inches long. Insert the strips into the hole through the spool one by one, putting in the longest ones first at the side nearest where the terminals are brought out, and finishing up with the shorter pieces at the opposite side. Enough strips should be used to fill up the hole

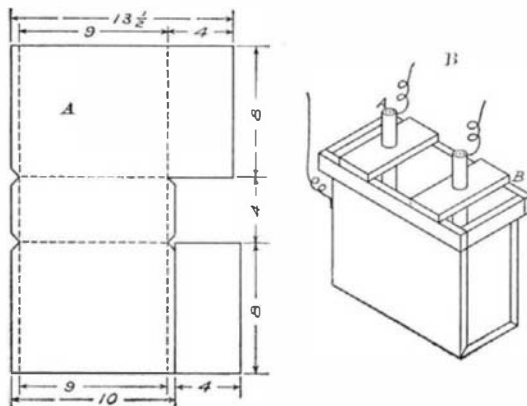

Fig. 2.—THE SHEET-LEAD TANK.

snugly. If the strips are rusty it will not be necessary to insulate them from each other, but if they are clean and bright it is a good plan to insert an occasional strip of paper so as to divide the core up into groups of half a dozen sheets each.

The strips must next be bent around, one at a time, so that their ends meet at the side of the coil opposite the terminals. Trim off the ends of each strip with a pair of tinner's snips so that they meet without overlapping, forming what are known as "butt joints." Care should be taken that the successive joints do not come in the same place, but overlap each other about two inches as they pile up, in the same way as the joints in brickwork. After the ends are all in place, they may be held permanently by wrapping them with a layer of stout cord (not wire) as shown at T, Fig. 1. This completes the autotransformer, though a coat of black paint will improve it.

The electrolytic cell consists of a lead tank nearly filled with a suitable liquid in which are immersed two rods of aluminium supported by a light wood frame, as shown in Fig. 2.

The tank should be made of sheet lead not less than 3/32 inch in thickness. A good size is 4 inches wide, 9 inches long, and 8 inches deep. Fig. 2 indicates how a piece of the sheet lead 14 by 20 inches may be used most economically. Cut out the two pieces as shown, fold on the dotted lines so that the joints lap on the outside, and solder the seams heavily with ordinary solder. Do not try to use a lead-lined wooden tank, as the success of the apparatus depends largely on the cooling effect of the surfaces exposed to the air.

For the electrodes, two round aluminium rods 3/4 inch diameter and 6 1/2 inches long are required. These must be of commercially pure aluminium, and not the so-called "hard stock" or alloy. Fasten to one end of each rod a piece of No. 16 copper wire to serve as a terminal. The best way to do this is to drill a small hole through each rod near one end, and then insert the wire and drive down the aluminium with a center punch until the wire is tightly pinched. (See Fig. 2A.) The tank itself also serves as an electrode, so that it is necessary to solder a wire to it somewhere on the outside. The aluminium rods are best

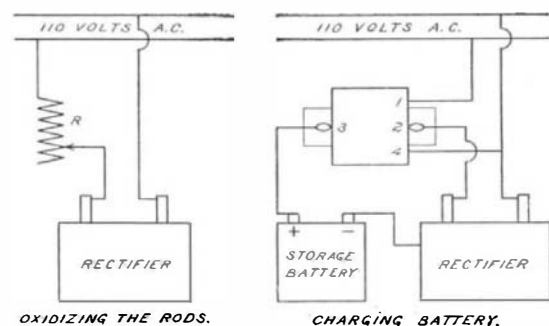

Fig. 3.—METHOD OF CONNECTING UP THE RECTIFIER.

supported in the tank by means of a light wooden frame made of six pieces as shown at B, into which the rods may be clamped by thin wooden wedges driven in where they pass through the holes.

To make up the liquid for the cell, put two pounds of crystallized sodium phosphate in the tank, and fill up the latter with about one gallon of lukewarm (not hot) water or enough to fill it to an inch from the top. Stir with a stick until the salt is dissolved, and then adjust the aluminium rods so that they dip into the solution three inches.

Before the apparatus can be set at work the rods must be coated with a film of oxide. This has to be formed by the alternating current itself, for which purpose the rods may be temporarily connected to the

110-volt power mains as shown in the first diagram in Fig. 3. A resistance, R, of about ten ohms must be used to prevent too much current from passing at first. After half a minute this resistance may be gradually reduced to zero, and the operation will be completed.

For actual service the autotransformer, rectifying cell and storage battery are to be connected up as shown in the second diagram in Fig. 3. The autotransformer may be connected to a 110-volt lamp socket by means of a sufficient length of No. 16 lamp cord and an attachment plug. A two-ampere fuse should be included in the circuit.

The windings of the autotransformer have been so proportioned that when connected to 110 volts about 2 1/2 amperes will flow through a six-volt, sixty-ampere-hour battery. This low rate of charging contributes to long life of the battery, and at the same time minimizes the amount of attention necessary in charging, since an overcharge at low rate does very little harm. With ordinary use of an automobile, a ten-hour charge over night every two weeks will keep the battery full and in good order.

After about fifty or sixty hours' use of the rectifier the sodium phosphate solution will become exhausted. This will be indicated first by unusual heating of the tank and autotransformer, due to leakage currents, and finally by the blowing of the main fuse and possibly the discharge of the battery back through the tank and coil. It is therefore necessary to make up a fresh solution for the tank and reoxidize the rods after about fifty hours' use, or when excessive heating is first noticed.

The aluminium rods last a long time, and when the lower ends become worn thin they may be inverted if care be taken to remove every particle of the copper connecting wires.

The apparatus will charge an eight-volt battery, if necessary, but at a slower rate, and it can also be used on a four-volt battery in an emergency. In the latter case the large currents may soon cause overheating unless a resistance of about one ohm be connected in series with the battery.

SAW-FILING CLAMP.

BY C. A. PITKIN.

The saw clamp, described by Mr. Bayley in the SCIENTIFIC AMERICAN of May 15th, is of service in the workshop, and I should like to submit a modification

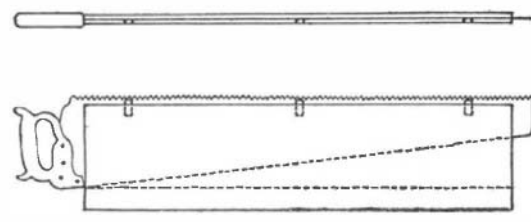

HANDY SAW-FILING CLAMP.

of it, as used by carpenters and others, when the facilities at hand are limited.

Oftentimes when one wishes to file a saw, while away from the shop, and having no filing clamp at hand, he is at a loss to know how to firmly hold the tool during the operation. A handy expedient is to take a board or joist and turning it on edge, end on, make a cut with the saw to almost its depth. Then place the saw in the cut, teeth uppermost, and drive in several small wedges along one side. This always holds the saw nicely, and the whole may be nailed to a step, sill, or part of the framing, or may be placed in a carpenter's vise. To loosen the saw, strike the top of its handle with the hand.

TO SUPPORT SHAFT WHEN BABBITTING.

BY J. EDWIN KERR.

This is a suggestion for the simplification of the babbitting of crankshaft boxes, which has been used a number of times with entire satisfaction. Drill two holes about 1/4 inch from the outside end of the box and in about the position shown in cut. Tap the holes for small screws. Let the shaft rest on the head of these screws, which may be adjusted until the shaft is lined up. After lining the shaft it may be taken

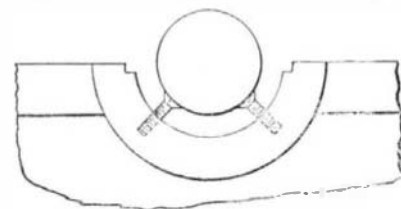

SUPPORT FOR SHAFT WHEN BABBITTING.

out of the box and warmed before pouring the babbitt, preventing the metal from being chilled and forming an uneven surface. The shaft may be replaced while warm and the babbitt poured at once, the screws insuring a perfect line-up. The screws may be removed with a screwdriver when the babbitt has been poured, or they may be left in if brass screws are used.