

of a smaller diameter than the greatest inside diameter of the piece. The main thing to guard against, therefore, in making the mold for this piece is the core. Care must be taken to have the distance *B* shorter than the diameter of the inside core or cone *C*. If this is not done, it will be impossible to get the core out of the finished cast. It might be well to state the progressive operations in the making of this mold. They are as follows: First, make inner core or cone. Second, build up outside part of core. Third, remove outside part of core and cut into pieces as shown. Fourth, reassemble core and place in spinning box. Fifth, build up and turn plaster model of piece to be cast. Sixth, remove all pieces from spinning box and cast outside mold. Seventh, cast case.

(To be continued.)

A LADDER EXTENSION LEG.

BY I. G. BAYLEY.

A painter or any other mechanic is sometimes called upon to paint or repair work which is very unhandy to reach. Perhaps a ladder is to be supported in some manner upon a slanting roof of a shed, or other building. Such a case happened very recently, when the following scheme was adopted by a mechanic with success:

A ladder, *A*, was supported from the peak of the shed roof by means of a plate, *B*, bent in the shape of a hook. Two painter's hooks would do just as well. The plate, *B*, was about 8 or 10 inches wide and 3 feet 6 inches long before being bent. The grip on the roof peak should not be less than 6 or 8 inches. The second or working ladder, *C*, was supported on the first ladder, *A*, by an extension leg, *D*, made of 4 by 3 timber of tough quality. The foot of this leg, *D*, was

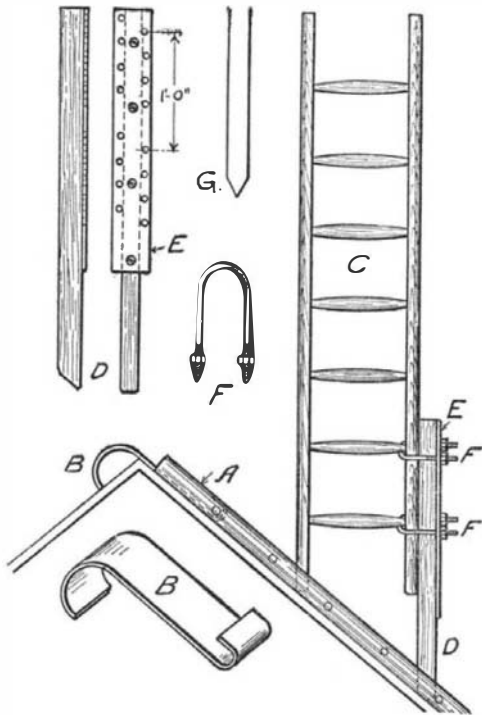

HOW TO SUPPORT A LADDER ON A SLANTING ROOF.

shaped as shown in detail to fit against the rounds of the ladder on the roof. A plate, *E*, furnished with a number of holes for a couple of U bolts, *F*, was screwed down to the leg, *D*. The holes were staggered, and spaced 2½ inches apart on each side, allowing adjustment of 1¼ inch each way, to accommodate different pitch of roofs. The distance apart of each group of holes in the plate, *E*, should equal the distance apart of rounds of the ladder, usually 1 foot, so that the rounds of the ladder will bear on the U bolts, which should be drawn up tight when the proper adjustment has been made.

If the extension leg was made of steel, of smaller dimension than the timber one, furnished with a sharp point, *G*, to stick in the shingles of the roof, the ladder, *A*, and hook, *B*, could be dispensed with.

AUTOMATIC LUBRICATING CUP.

BY W. J. C.

In lubricating the reciprocating parts of vertical engines, there is considerable waste of oil, and the lamp wick dangling from the end of the oil pipe forms a collector of dust and grit, which is carried to the bearings. The waste of oil is principally through the fact that when the engine stops the oil still continues feeding, and drops into the crank pit rather than into the oil cup.

Much of this can be avoided by the use of an oil cup such as shown in the accompanying sketch. It consists of a cup of the usual shape having inside a mushroom-shaped valve *B*, which is ground to a tight seat at *E*. The stem *D* passes through a clearance hole *C*, in the bottom of the cup. When the cup is filled with oil, the mushroom valve prevents its flow as long as the engine is at rest.

The cup is placed directly over the oil cup which is to receive the oil, and which moves in a vertical direction. By means of adjusting screws its height is so

arranged that the stem of the valve is raised slightly as the oil cup comes to the top, thus allowing a small amount of oil to pass inside the valve and flow down the stem. The receiving cup should be filled with horsehair, to rub off the necessary oil from the stem.

The oil flows only when the engine runs, and in proportion to the speed of the engine.

No time is lost nor oil wasted in shutting off the

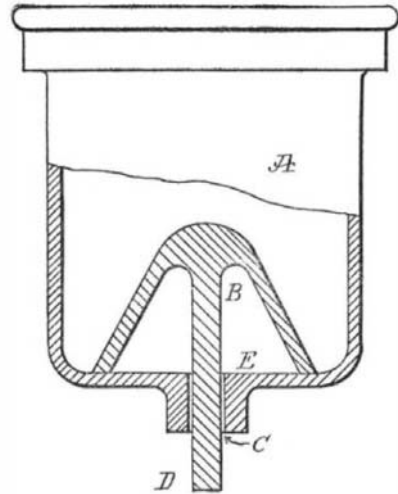

AUTOMATIC LUBRICATING CUP.

supply when the engines are secured, and the stem can be easily wiped clean of all dust if it has remained unused for some time.

This cup could be used on horizontal engines by a slight modification of the stem; but on vertical marine engines, as on tugs, where the engine is run intermittently, the writer has seen it do good service and save many times its cost in oil, labor, and hot bearings.

EXPERIMENTS WITH ALTERNATING CURRENT, USING A SMALL DIRECT-CURRENT MOTOR.

BY F. P. McDERMOTT, JR.

A small direct-current motor, such as can be purchased for about a dollar, will operate in various ways as an alternating-current motor. These methods of operation are not recommended for regular use, but they serve as excellent experiments with alternating currents.

A series-wound motor with a three-part commutator is suitable. Owing to the variety of such motors on the market, only general directions can be given here, leaving the details to the judgment of the experimenter. If the motor is to be connected to an alternating-current circuit of about 110 volts, it is necessary to have some means of limiting the current passing through the windings. The diagrams show a lamp rheostat used for this purpose. The rated voltage of the lamps should not be less than the voltage of the circuit, for the resistance of the motor may be so low that the lamps will receive almost the full voltage of the supply, and they would then be burned out if made for a lower voltage. A rheostat enabling any number not exceeding ten of 16-candle-power carbon filament lamps to be connected in parallel is large enough. In determining whether the wiring and fuses through which the current is supplied have sufficient carrying capacity, remember that each lamp takes about ½ ampere when supplied with its rated voltage. The current per lamp will be less than this when the motor is in series with the lamp rheostat.

Make the connections to the motor with all of the

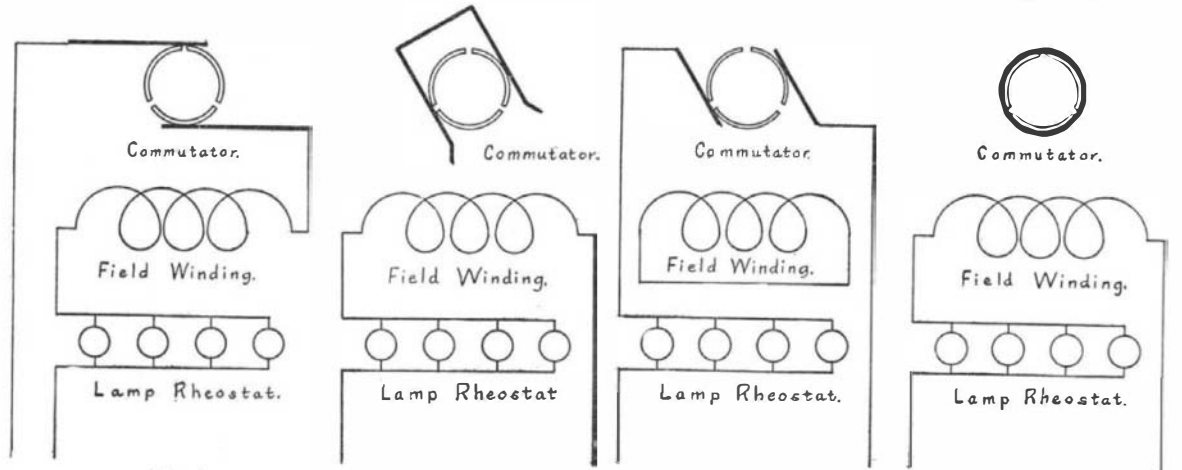

DIAGRAM OF CONNECTIONS FOR THE EXPERIMENTS.

lamps turned off, and start by turning on the lamps until the motor receives sufficient current. Do not turn on so many lamps that the motor attains an excessive speed or temperature.

Of course, a suitable step-down transformer or a reactance coil may be used instead of a rheostat.

When the motor is in proper condition to operate as a direct-current series motor, it may be operated as an alternating-current series motor. With the exception of inserting the rheostat, the motor is connected to the alternating-current circuit in the same way that

it is connected to a battery when run as a direct-current motor. (See Fig. 1.) To reverse the direction of rotation, transpose the wires connected to the brush holders, as would be done to reverse it when operating with direct current.

A repulsion motor consists of a stationary field magnet, through the winding of which alternating current is passed. The armature is similar to a direct-current armature. Instead of the two brushes, or, in larger machines, the two sets of brushes (corresponding to the positive and negative sets of brushes in a direct-current machine) being insulated from one another, they are connected together. To run the motor as a repulsion motor, it will be necessary to shift the brushes until the proper position for operation is found. If the brushes supplied with the machine can be readily shifted, then they may be connected together by connecting a wire to the two brush holders. If they cannot be readily shifted, remove them and bend a piece of copper wire into the shape shown in the diagram (Fig. 2) so that it can embrace the commutator and touch it at diametrically opposite points. This wire acts as two brushes connected to one another, and for experimental purposes may be held in place by hand. After the brushes have been arranged, pass current through the field winding, as shown in Fig. 2, and vary the position of the brushes until the motor runs.

The inverted repulsion motor differs from the repulsion motor in that the alternating current is supplied to the armature, and the field winding is short-circuited. To obtain this motor (Fig. 3) connect together the two ends of the field winding and supply current to the armature. As was the case with the repulsion motor, it is here necessary to shift the brushes until the proper position for operation is found. If the brushes supplied with the motor can be readily shifted, supply current to the armature through them. Otherwise, the current may be supplied to the armature by removing the regular brushes and pressing the wires carrying the current against the commutator at two diametrically opposite points, shifting them until the proper position for operation is found. The repulsion and inverted repulsion motors are reversed by shifting the brushes.

In the single-phase induction motor current is supplied to the stationary winding, and the revolving part consists of a winding having short-circuited coils, or else a squirrel-cage winding.

To obtain the induction motor, wrap a few turns of wire around the commutator, so that each coil of the armature is short-circuited. Run without brushes, supply current to the field winding only, according to Fig. 4. Unlike the other motors here described, the single-phase induction motor is not self-starting unless special devices are provided to make it so. When these devices are absent, as in the case here, the motor will run equally well in either direction when once started. Start by giving the shaft a twist with the fingers or by wrapping a piece of string around the shaft and rapidly pulling it off.

For the theory of these motors, and also the modifications in construction used to secure better operation, consult textbooks on alternating currents.

DEVICE FOR REMOVING BROKEN WOOD SCREWS.

BY G. H. SINCLAIR.

For the past fifteen years I have successfully used a tool for the removal of broken wood screws made on the same lines as the soft brick pipe drill shown in Handy Man's Workshop of February 27th, 1909.

The size of the pipe needed can be obtained from the shank of the broken screw, though it is desirable that the pipe should be a trifle larger, to allow for clearance and in case the screw should not have been run straight. Any piece of brass or steel tubing can be used; while steel is better, brass is more readily obtained. After the teeth are filed, bend every alternate tooth out a trifle for clearance. Use this pipe bit, and bore out the broken off screw. Glue in a plug, and you can run in a new screw, never knowing the old one had been broken.