

to shellac and oil all parts of the plaster mold which will come in contact with the cement. Then set up the mold as shown in Fig. 13, care being taken to bind the outside form firmly together by means of string. The mold is now ready to receive the cement mixture, which should be made as follows: Take 1 part of Portland cement and 2 parts of marble dust, if a fairly light color is desired; if not, 2 parts of any good clean fine sand will do. Mix these thoroughly together while dry, and then add enough water to allow the whole to be mixed to the consistency of a heavy cream. Let it be thin enough so that it will pour freely. Pour this mixture in the openings *a, b, c, d*, between the outer plaster mold and the core, until the mixture is flush with the bottom of the core. Lift the mold and gently jar it. This will tend to settle the cement, and will also force out any air that may be in the mold, and thus avoid the trouble of air bubbles or voids in the finished cast. The cement already deposited in the sides will settle, more or less, under this treatment. Now fill the remaining portion of the mold flush with the top of the outside plaster sides and jar the mold again. Repeat this operation until the cement will settle no more. Wipe off the top of the mold with a straight edge, thus removing any surplus cement, and giving to the bottom of the box a good even surface. Then place the mold in a level position, and allow it to stay there without moving for from 24 hours to 48 hours, the longer the better, as the longer it is allowed to remain, the harder the cement will set. After having set for the above-mentioned time, the piece can be removed from the mold. The method of doing this is as follows:

Turn the mold over into the position shown in Fig. 12; tap the case *A* around its edges; this will loosen the case, which is then removed. Now take the screw eye and insert it in the hole in the piece 1 of the core. Pull this out, and then repeat the operation in pieces 2, 3, and 4 of the core. Cut the string which binds the sides together, and then pull them off in the directions indicated by the arrows in Fig. 10.

If care has been taken throughout all of the above operations, the result will be a perfect cast. The next step is the curing of the box. This is a simple operation. All that is necessary is to soak it well with water. This can be done by placing the cast directly in water, and letting it stay there for one or two days, or it can be sprinkled or dashed with water three or four times a day for two or three days in succession or longer; the longer the process is kept up, the better the result. By the application of plenty of water, the product produced will become as hard or harder than stone.

(To be continued.)

ICELESS REFRIGERATION.

BY EDWARD THORPE.

While the mad race for supremacy between the mercury and price of ice continues, much comfort can be taken in the fact that there are other methods of

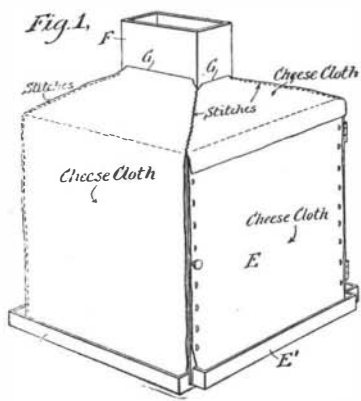

REFRIGERATOR COMPLETE WITH TANK UNCOVERED.

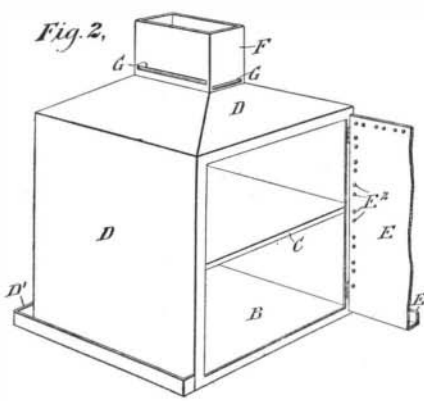

CLOTH REMOVED TO SHOW THE ZINC BOX.

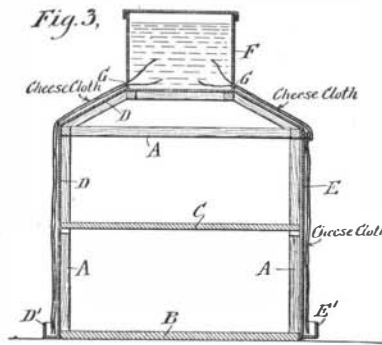

CROSS-SECTIONAL VIEW OF REFRIGERATOR.

keeping victuals cool besides that of melting ice in an ice box. If in changing from the solid to the liquid state water absorbs sufficient heat to keep an ice box cool, it is equally true that a change from the liquid to the gaseous state will result in refrigeration, provided, of course, the rate of vaporization keeps pace with the heat which enters the ice box from the outside atmosphere. Under proper conditions it is possible by this method to maintain a sufficiently low temperature in the ice box to preserve food from rapid decay. A simple method of making such an iceless refrigerator is illustrated in Fig. 1. In this illustration the cover of the water tank is removed. The box comprises a frame *A*, which is built upon a wooden floor *B*. The frame *A* serves as a support for a zinc box *D*, which is fastened thereto. The water tank *F* is soldered to the top of the box, while at the bottom is a trough *D'*. The door *E* at the front of the box has its own trough section *E'*. Slots *G* are cut in the four sides of the tank *F* to receive the ends of a cloth cover for the box. The cover is preferably made up of several thicknesses of cheesecloth stitched

together at the corners, and the ends are jammed tightly through the slots into the water tank *F*. The door *E* is provided with its own section of cheesecloth, as indicated in the illustration. In operation the water from the tank soaks into the cheesecloth and by capillary attraction and gravity passes on down to the bottom of the cloth, where any excess of water is caught in the trough. The flow of water through

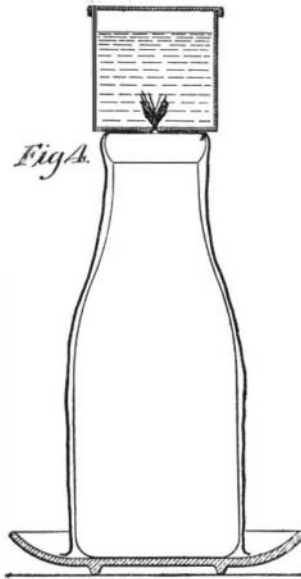

HOW TO KEEP A MILK BOTTLE COOL.

and over the cloth should be very slow, and may be regulated to a large extent by the tightness with which the cloth is stuffed into the slots *G*. The box is placed on a suitable shelf supported by brackets just outside of the open window on the breeziest side of the house and out of the direct rays of the sun. It is advisable to make the box a couple of inches narrower than the window opening, so that the currents of air passing in and out of the window may have free passage all around the moist cheesecloth. As the water in the cheesecloth is evaporated it absorbs a large amount of heat, much of which is taken from the zinc box, tending to keep the food in the box cool. A modification of this idea is shown in Fig. 4. Here the construction is adapted to cool an individual milk bottle. The cloth covering is placed directly over the bottle, and at its upper end is jammed into a slot in the bottom of the small reservoir. The milk bottle is placed in a saucer, which serves as a trough to catch the excess of water. Instead of the cheesecloth covering, the leg of a sock can be used, as this is already of cylindrical form and is well adapted to hold the moisture. In case the water from the tank does not moisten the cover sufficiently, the trough may be also filled, and the water will be drawn up therefrom by capillary attraction.

A WEATHERBOARD GAGE.

BY L. G. BAYLEY.

It is customary, when cutting off weatherboarding to fit up against the corner strips of a frame house, to use the long square or carpenter's rule. The square is sometimes held along the edge of the weatherboard, or down the side of the corner strip. Either method necessitates carrying the square along, or fetching it from where it was laid down.

One-quarter the time can be saved, saying nothing of the convenience, by making a little gage as illus-

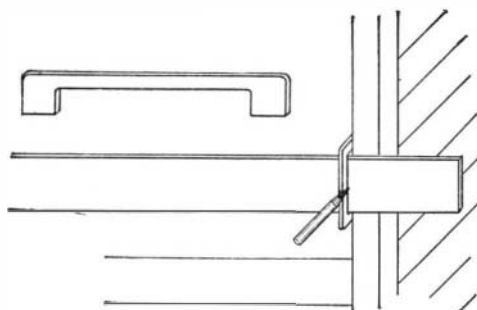

A WEATHERBOARD GAGE.

and held firm against a pencil line on the board as it is held against the wall. The gage is made a little inside the pencil mark.

QUICK MEANS FOR FINDING THE CENTER OF SHAFTS.

BY ALBERT PRATHER.

In the illustration the circle represents a section of a shaft, the center of which it is desired to find. The corner of a square is placed on any point of the circumference.

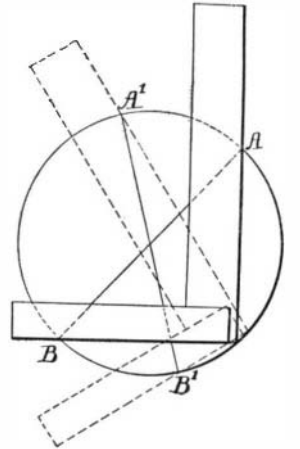

METHOD OF FINDING CENTER OF A CIRCLE.

Draw a line from *A* to *B*. Now shift the square a little, as represented by the dotted square, and with the corner on any other point mark the intersections *A'* and *B'*, then connect *A'* and *B'*, and the intersection of *AB* and *A'B'* will be the required center. It is necessarily the center, for it is the intersection of two diameters.

A HOME-MADE SAW VISE.

BY JAMES G. NEWLAND.

Desiring a saw-filing vise that would allow an ordinary saw to be filed or set from end to end without change and without chattering, to hold the saw rigidly and yet so that it could be instantly released, the writer made a device as follows: In the barn loft there was a south window with a good light. To the 2 x 4 studding at each side of the window and at right angles to it, at a convenient height two pieces of wood 1 x 12 x 12 inches were firmly nailed, thus forming two brackets. Two pieces of straight 2 x 1/4-inch flat iron, long enough to go across these brackets, were found, also two straight pieces of 1 x 1-inch iron (discarded square-bed carriage axles with stubs off). The latter pieces were faced with the flat iron by means of a couple of countersunk-head stove bolts. Two pieces of 2 x 2-inch angle iron would have done as well. These made the two jaws of the vise, and they were

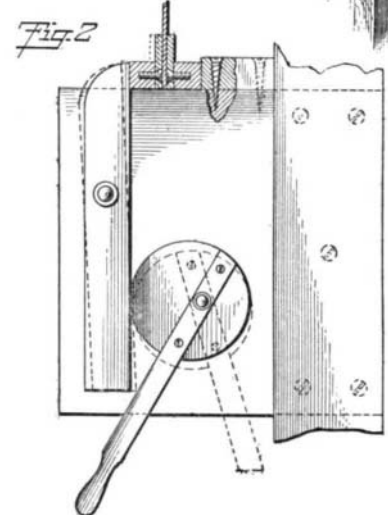
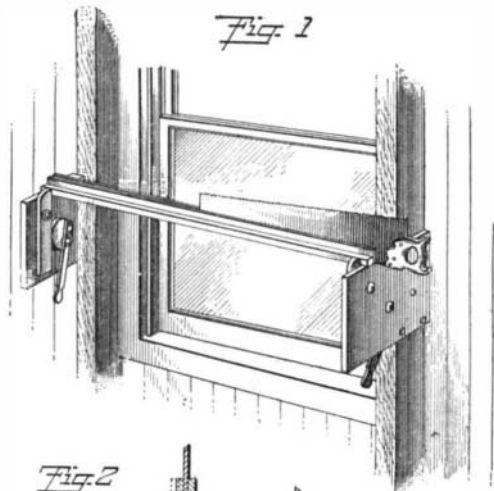

A HOME-MADE SAW VISE.

placed across brackets in front of the window, with a wooden strip between the inside jaw and the studding to take the file thrust. On the inner side of each bracket a lever of 1 1/4-inch square hardwood was pivoted with its upper end bearing against the outer jaw. Two circles of wood were cut and mounted on bolts in the brackets, but an inch off center, so that they could be used as cams to press against the lower ends of the lever and force the upper ends firmly against the outer jaw, thus clamping the saw firmly in place. A handle was secured to each cam, with which to tighten and release the vise.