

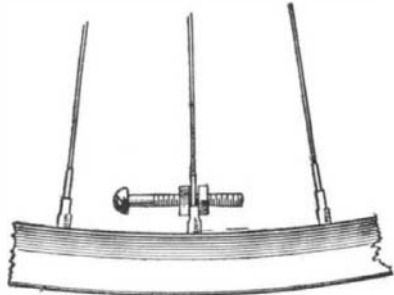

**IMPROVED NIPPLE GRIP.**

BY THOMAS DE LOOF.

When one wishes to replace a few broken spokes in a bicycle wheel, he often finds that he has no nipple grip, while a bicycle wrench proves to be too long to get in around the spokes. A good nipple grip



**IMPROVED NIPPLE GRIP.**

can be made by putting two nuts on one bolt, as shown in the accompanying engraving.

**HOW TO WATER-PROOF CLOTH.**

For rain coats or other water-proof clothing, woolen goods having a close weave are the best. Use goods in which the face is smooth and firm, although cloth having a soft face answers fairly well, provided the weave is tight and close. To water-proof the cloth, lay it out on a large table face up. Then take a block of paraffine about six inches square and rub it all over the face of the cloth, bearing down hard. This will leave a thin film of paraffine on the face of the cloth. Melt this film of paraffine into the goods, using a flat iron that is just warm. Too hot an iron will set the paraffine on fire and burn the goods. It is well to experiment with a small sample first, and learn how to do the water-proofing properly before starting in with a pattern of goods. To determine when the sample is properly water-proofed, hold it in a kind of bag, with the face in, and pour in some water. If the water-proofing has been properly done the water will not wet the face of the cloth, but it will stay in globules and act as if it were on a greased board or hot stove.

**SLED RUNNER ATTACHMENT FOR GO-CARTS.**

BY MILTON STONE.

The writer made a pair of runners for his go-cart last winter which proved quite a success. They were made of 1-inch by 1/8-inch iron, and weighed altogether six pounds. The construction was such that they could be applied or removed in a few seconds. Referring to the accompanying illustration, it will be seen that two wooden side pieces *A* were provided, to which the runners *B* were fastened. The wooden side pieces were cut out and grooved to receive the wheels, and the runners were curved up to fit against the front

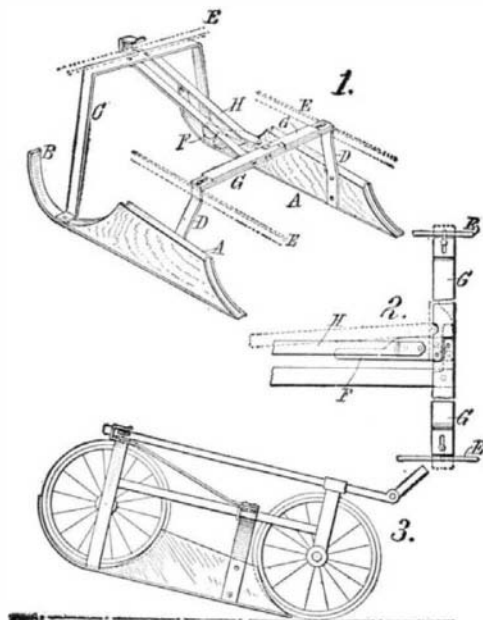

**SLED RUNNER ATTACHMENT FOR GO-CARTS.**

wheels. A U-shaped frame *C* of strap iron connected the runners at the forward end, while they were connected at the rear by a second and lower frame *D*. The frame of the go-cart is indicated by dotted lines at *E*. A pair of sliding members *G* were fitted onto the U-frame *D*, and attached to a lever *F* in such manner that they could be extended over the side bars *E* after the go-cart was fitted over the runners. A strap

*H* extending forward to the frame *C* was formed with a hook, so that when the lever *F* is moved to extend the members *G*, the strap *H* is retracted, causing the hook to fit over the front cross piece *E* of the go-cart frame. In applying the runners to the go-cart, it is merely necessary to raise the front wheels so as to clear the side pieces *A*, and then move the cart into position, after which the lever *F* is moved to lock the runners fast. One of the advantages of this system is that the runners at the rear are so short that when the cart is tilted backward the wheels rest on the ground, and in that position they can be wheeled over any bare spots.

**A SNOW-BOUND SANTA CLAUS.**

BY JOHN A. BERGSTROM.

The accompanying illustrations show how a very pretty effect may be obtained in Christmas tree decoration. It has the appearance of a Christmas tree in a snow storm.

Stretch a cord above and in front of the Christmas tree with one end fastened to a hook or a nail and the other end to the armature of an electric bell. Hang from this cord a number of fine threads to which at intervals small pieces of cotton are fastened. The bell is connected up to a battery with a push button in the circuit. When this button is pushed, causing the armature and cord to vibrate, the quivering bits of cotton look like falling snow. The armature of the bell should be bent back a little so as not to strike the bell, which may be covered up with a wreath or other decoration.

Fig. 1 illustrates how the cotton may be attached to the threads.

A frame is first made a little longer than the cur-



**SANTA CLAUS IN A SNOW STORM.**

tain. This may be made out of any kind of rough lumber and nailed together. At one end of the frame two rows of pins are put, about 1/2 inch apart. The pins in each row should be about 1/8 inch apart. At the other end of the frame is put another row of pins 1/8 inch apart.

Now wind the cord around the two rows of pins and fasten the ends, as shown. Then fasten the end of a fine thread to the cord at the first pin. Bring the thread down to the lower end of the frame and wind around two pins, then back again and fasten to the cord. Repeat until the required number of threads are obtained. Now take a fine brush, preferably a painter's striping brush, and apply glue to the threads, crossways, about two inches apart, the whole length of the curtain.

Cut some thin cotton batting into strips about 1/8

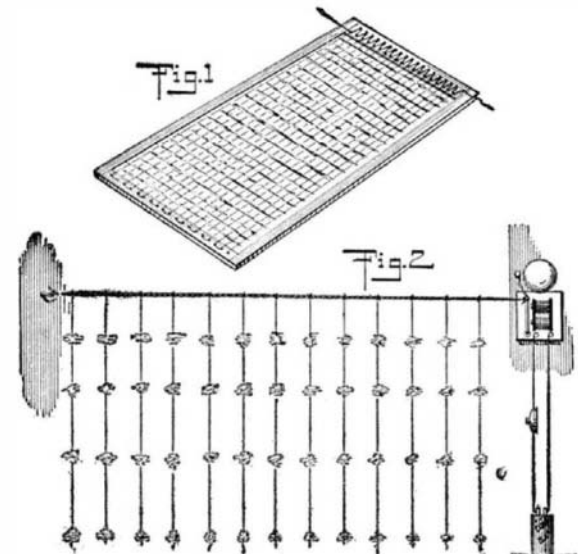

**APPARATUS FOR PRODUCING THE SNOW STORM EFFECT.**

inch wide, and place them across the threads where the glue has been applied, pressing them down onto the threads.

When dry cut the lower ends of the threads and pull each individual string away from the rest. Just enough cotton will stick to each string. After all the strings have been separated remove the cord at the upper end of the frame and the curtain is ready to be hung up. Fig. 2 shows a part of the curtain when finished with threads about 1 inch apart.

**HOW TO MAKE LEAD PIPE INTO IRON PIPE WITHOUT A WIPED JOINT.**

BY HOWARD M. NICHOLS.

It takes a skilled plumber to make a lead pipe into an iron pipe, using a wiped joint, but using the following method any mechanic can make a permanent joint

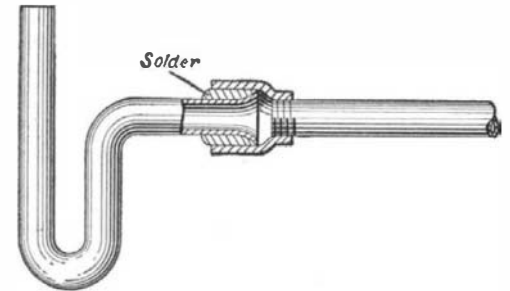

**SIMPLE METHOD OF CONNECTING LEAD AND IRON PIPE.**

which is equally as good as a wiped joint. The accompanying drawing shows a lead *S* made into a galvanized-iron pipe. The large end of a reducing coupling is placed over the end of the lead *S*, and the end is then flared out with a blunt piece of steel, so that it will flare out and fit the coupling snugly, as shown. The space between the lead pipe and the coupling is then filled with hot solder, which is allowed to round out on the pipe and make a smooth joint. To complete the job, the iron pipe is then screwed into the small end of the coupling.

**A METHOD FOR CONNECTING BATTERIES IN COMBINATIONS.**

BY CHAUNCEY W. NIEMAN.

The inventor who deals much with electricity is bound to find himself sooner or later greatly hampered in experiments with batteries by the necessity of frequent changing from parallel to series, etc. It is one of the little routine details which makes most of the worry in experimenting, for the connecting up of a dozen wires may often cause the loss of a happy "inspiration." A convenient and easily made switch-board is illustrated herewith, and it will add its mite of comfort to the harassed inventor. This board, for six batteries, allows all possible connections, and by adding more points can be adapted to any number of batteries.

It is made as follows: The "board" is a one-inch piece of wood, mounted if desired on feet. In this bore ten holes, to receive an equal number of stove bolts, as-per plan in Fig. 1. The bolts should be provided with large washers, and the holes so bored as to allow a distance of 1/8 inch between the washers when in place. Next two metal strips should be fastened by two stove bolts each, one strip on either side of the rows of bolts. The distance between the strips and the edges of the washers should be 1/8 inch also. At the points indicated by the dotted circles bore 3/8-inch holes half way through the board. Plugs should then be made, and consist of strips of sheet copper or brass, 1/4 inch broad, bent as shown. Wires are then led from each pole of every battery and connected underneath the board to the bolts.

The wiring diagram is given in Fig. 2. Batteries are numbered from 1 to 6, and the positive and negative of each battery are connected to the bolt so marked. Current is taken off at the points *X* and *Y*. An understanding of the key given below will enable anyone to make the combinations indicated with great speed and almost no trouble.

- Insert plugs at *F, G, H, K, and L* to obtain all in series.
- C, F, G, K, L and P* 2 parallel sets of 3 in series.
- B, D, F, H, L, N and Q* 3 parallel sets of 2 in series.
- A, B, C, D, E, M, N, P, Q and R* all in parallel.

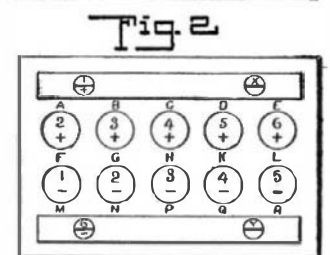
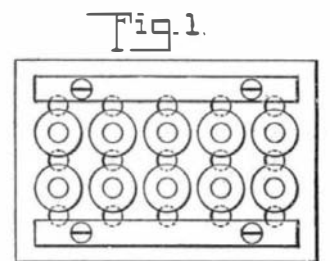

**A SIMPLE BATTERY SWITCHBOARD.**