

THE SELF-SMOKING PIPE.

After filling a decanter about two-thirds full of water, close it by means of a cork provided with two apertures. Through one of these pass a short pipe stem and through the other a longer stem that enters the liquid.

To the smaller tube affix a cork provided with two apertures. The apertures may be easily formed by means of a red-hot poker. The lateral aperture serves to fix the pipe. Finally, with the other cork and a bent

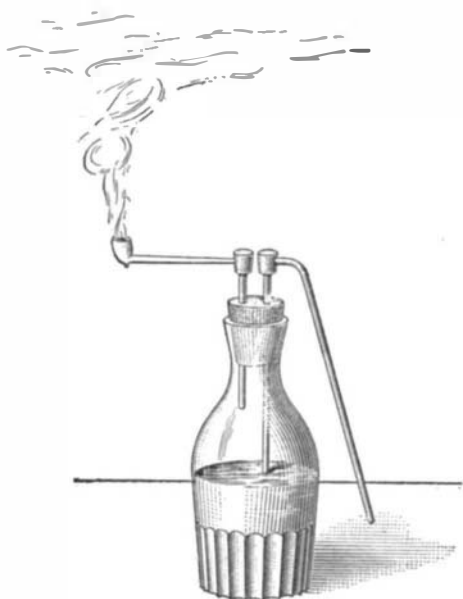

THE SELF-SMOKING PIPE.

tube, form a siphon. After the latter has been primed and is once in operation, it will tend to empty the decanter, and the vacuum formed will be immediately filled by the external air flowing in through the pipe. It is then only necessary to light the latter in order to see it "smoke itself" tranquilly as long as any water remains in the decanter.

This experiment is a very interesting one and may easily be performed.

HOME-MADE KNOB AND TUBE BORING MACHINE.

BY R. H. BROCKMANN.

To electricians who install knob and tube wiring, a machine that will bore the overhead beams is a great time and labor saver. The drawing shows a machine for this purpose that can be easily and cheaply made by anyone handy with tools.

The framework *A* is made of hard wood, oak or hickory, firmly put together, and made long enough, so that when fully extended it will reach ordinary high ceilings. The height can be adjusted by means of the sleeves *B* and the thumb-screw. If it is too much bother to make the sleeves *B*, ordinary iron clamps can be used. *C* is a piece of wood fastened to the frame by means of a hinge at one end and a light flexible wire cable at the other, *E*. Points are formed at the bottom of the frame to keep the machine from slipping.

A piece of machinery steel *D* is drilled to form a

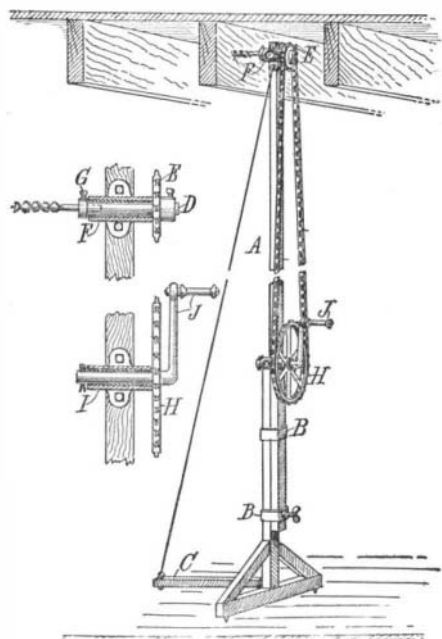

HOME-MADE KNOB AND TUBE BORING MACHINE.

socket for the bit. It is turned down to form a shoulder at the socket end and is then held in the 1/2-inch drop tee *F* while Babbitt metal is poured in to make the bearing. A nine- or ten-tooth bicycle sprocket *E* is mounted on a bushing and fastened to the shaft with a set screw. A set screw *G* is also provided to hold the bit in place. Round-shank bits are intended to be used. The drop tee *F* is then fastened to the frame *A* by means of bolts. The sprocket *H* and crank and pedal *J* of a bicycle are mounted in a 3/4-inch drop tee *I*

and given a good bearing by pouring Babbitt metal around the axle. A hole is then bored through the other end of the axle and a washer and pin put on. The rat trap or cage part of the pedal is removed; this leaves the central part with the ball bearings, which makes a very good handle. The drop tee *I* is then bolted to the frame *A* and a bicycle chain *J* is fitted onto the sprockets *A* and *K*.

To operate the machine, a bit of the proper size is inserted into the socket. The frame *A* is then extended to the proper height and made fast by means of the thumb screw. The operator then places the machine in position with the bit against the beam, and with his foot bears down the pedal *C*, thus forcing the bit firmly against the beam, while he bores the hole by turning the handle *J*.

INEXPENSIVE APPARATUS FOR ILLUSTRATING THE "HYDROSTATIC PARADOX."

BY F. R. GORTON.

A simple method for illustrating the "hydrostatic paradox" with inexpensive materials is described below.

In the small end of a large lamp chimney *C* is cemented with paster of Paris or paraffine the neck of a bottle of suitable size to fit a large rubber stopper (see *H* in figure). Across the small end of the chimney is tied a piece of thin sheet rubber *D*. A small glass tube *B* and a larger one *A* are provided with rubber stoppers which fit well in the aperture *H*. The apparatus is mounted firmly on the ring stand *S* as shown in the cut.

In the manipulation, tube *B* is inserted in the inverted chimney and filled with water to the level of the open end of *C*. As the force exerted by the water against the rubber increases, the index rises. The final position of the index is marked by a heavy black line

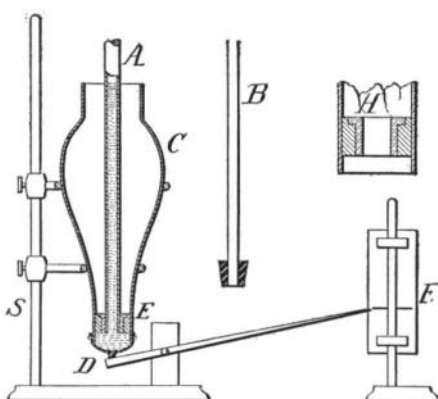

APPARATUS FOR ILLUSTRATING THE "HYDROSTATIC PARADOX."

on the cardboard which slides on the vertical rod *F*. Now tube *B* is removed and the larger tube *A* inserted and filled to the same level. The index rises promptly to the height marked by the line on the card *F*. Finally, tube *A* is removed and the chimney is filled to the brim. The index rises to the same point as before.

One of the chief merits of the device is the fact that no water has to be removed from the apparatus during the experiment.—School Science and Mathematics.

DEVICE FOR DRAWING OVOIDS.

BY J. O. BROUILLET.

The instrument illustrated herewith can readily be made by any handy man, and will enable him to draw ellipses of various sizes and ovoids as well. It consists of a sheet-metal piece *A*, in which two slots are cut crossing each other at right angles. A lever *B* is provided with two blocks *C* and *D*, adapted respectively to slide in the slots. A lever *F*, which is fulcrumed at the center of the plate *A*, is connected by means of a lever *G* with the end of the lever *B*. A pencil may be fitted through a hole in the lever *B*, and as this is revolved around the plate *A*, it will trace an oval or elliptical line. At the same time a pencil in the lever *G* will trace an ovoid, as indicated in the drawing.

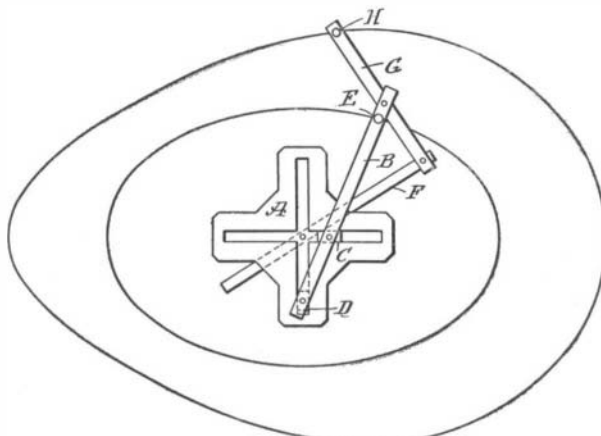

DEVICE FOR DRAWING OVOIDS.

DEVICE FOR WASHING PRINTS.

BY W. AND K. PARKHURST.

The device pictured herewith was devised to prevent prints from becoming torn while being washed. It is especially adapted to washing large prints, such as bromide enlargements, and is of such a simple construction that photographers will probably find it convenient to make several of them and thereby save much delay.

The material necessary is a quarter-inch board of slightly larger dimensions than the photograph to be washed, and four narrow steel springs; segments of a clock spring answer the case admirably. Each spring is clamped on the upper side of the frame, so that it turns over on the other side and securely holds each

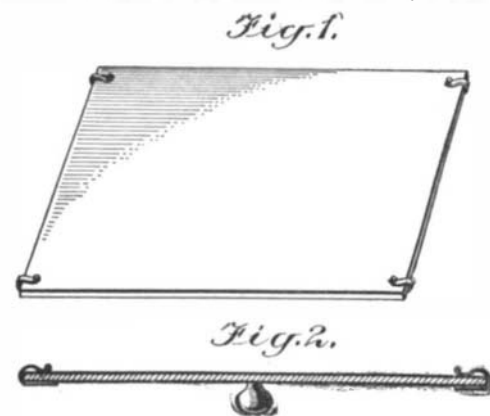

DEVICE FOR WASHING PRINTS.

corner of the print. Besides the ease gained in moving the prints about, without injuring them, the photographs are always completely immersed if simply left to soak.

BLUE ROSES.

BY PROF. GUSTAVE MICHAUD, COSTA RICA STATE COLLEGE.

The roses shown in the accompanying figure are white with a delicate and beautiful network of blue veins. Such roses can be obtained in little more than one hour by placing the following solution, instead of water, in the vase in which the cut ends of the stalks are dipping:

- Water 100 cubic centimeters.
- Aniline methylene blue. 2 grammes.
- Potassium nitrate 2 grammes.

School boys know that white roses can be transformed into red flowers by allowing the cut end to remain some time in some kinds of red ink. The writer tried to obtain similar results with a number of aniline dyes and found that while some, like aniline red scarlet, for cotton, readily rise into the vessels of the stalk, others, like aniline methyl green, will not under any circumstances reach the flowers. Some common salts were added to the dyes and one of them, potassium nitrate (saltpeter) was found to exert a powerful influence over the ascent of the dyes, which rise then rapidly and in considerable quantities. The experiment is curious and should be repeated while using the blue liquid; the end of a few stalks being placed in some of the solution to which no saltpeter is added. Aniline methylene blue is not one of the

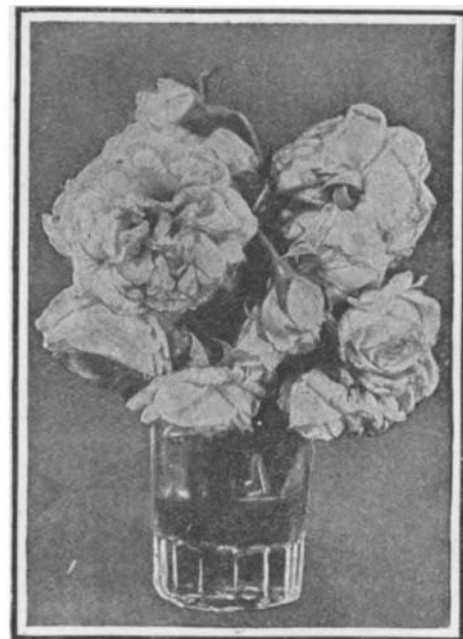

THE ROSES ARE COVERED WITH A NETWORK OF BLUE VEINS.

dyes which readily ascend in plants and it will be soon noticed that, while the flowers with the stalks dipping into the saltpeter and blue dye solution are covered with the blue network, nothing can still be detected on those whose stalks are allowed to dip in the same liquid but without saltpeter.

Will some botanist suggest an explanation of this influence of saltpeter on the ascent of dyes in stalks and flowers?