



HOW TO MAKE CONCRETE POTTERY.—I.

BY RALPH C. DAVISON.

Few people realize that anything of an artistic nature can be made from Portland cement. Most of us are used to looking upon this material as fit only for heavy construction work, such as foundations for buildings, bridge abutments, piers, etc. It is not remarkable, then, that the layman does not know that cement if used properly can be made to compare more than favorably with ornaments made from other and much more expensive materials; for even those who are in the trade, and working with it every day, know nothing of the wonderful and endless variety of artistic effects which can be produced with Portland cement.

The author for seven years has followed the Portland-cement concrete industry more or less closely, and for the past two years has devoted his entire attention to it. Some time ago he started experimenting with concrete pottery, and the experiments conducted along this line have developed some very interesting and practical results.

The method of making cement pottery is simple when understood; and if the craftsman follows the directions as will be given in this series of articles, he will find it easy to produce results which are fully worth while. Each step in the operation from the raw materials to the finished product will be explained in detail, including the incorporation of color effects, water-proofing, various surface effects, etc.

Portland-cement mortar has peculiar characteristics of its own. It is unlike clay. Therefore in modeling it has to be worked differently. In modeling clay one can form it into almost any shape, and it will remain there, for the reason that it is more or less sticky, and the various particles of which it is made up cling or adhere to one another, and thus hold the entire mass together. Portland-cement mortar, of which cement pottery is made, is composed of a mixture of sand or marble dust and pure Portland cement mixed together in various proportions. This mixture is wet down with water, and then by turning over and troweling, is made into a plastic mass called cement mortar. It is next to impossible to model in this material, for the reason that unless it is placed in a mold or a form is used to hold it in shape, while in its plastic state, it will fall down. The first step then in cement pottery work is to make the form.

There are several methods of making forms. One is to make wire frames on which to build up the cement mortar, and another is to make wooden or plaster molds. In the latter method the cement is handled in an entirely different manner from that used for the

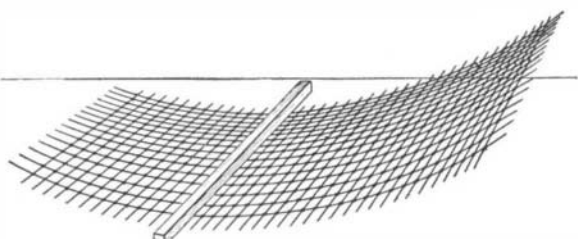
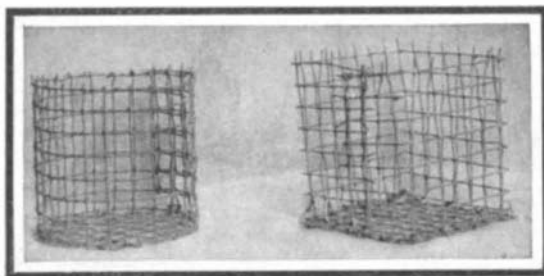

Fig. 2.—BENDING SIDE PIECE INTO CIRCULAR FORM.

former. The use of wire forms is the simpler when there are but one or two of the same shape of articles to be made. When a quantity of one kind is to be made, it pays well to spend some time in making a wooden or plaster piece mold, as it can be used over and over again, whereas when wire forms are used a new form has to be made for each article, whether of the same shape or not.

The best material for making wire forms is No. 20 Clinton wire lath having about a half-inch mesh. This

can be procured at almost any hardware store. When buying it ask for galvanized wire lath, as this is better and easier to work with than the ungalvanized. If not familiar with this material, the accompanying illustrations will give a good idea of what is to be used. The only tool necessary is a good strong pair of tinner's shears for cutting the wire, or better still, a combination wire cutter and nippers, as this will answer for two purposes. In the accompanying half-tone illustration are shown two completed frames, one for a square and the other for a round piece of pottery. The latter



ROUND AND SQUARE FRAMES FOR A PIECE OF CONCRETE POTTERY.

form is composed of a round piece for the bottom and a long narrow piece for the sides. (See Fig. 1.)

To make a wire form 5 inches in diameter by 4 inches high.—First cut a piece of the wire lath large enough on which to lay out a 5-inch circle. Hammer it out until it is perfectly flat, and then place the point of the dividers in the intersection of the wires near the middle of the piece. Set the dividers to a 2½-inch radius, and scribe the circle. A piece of red or black chalk is best for this purpose, as it will make

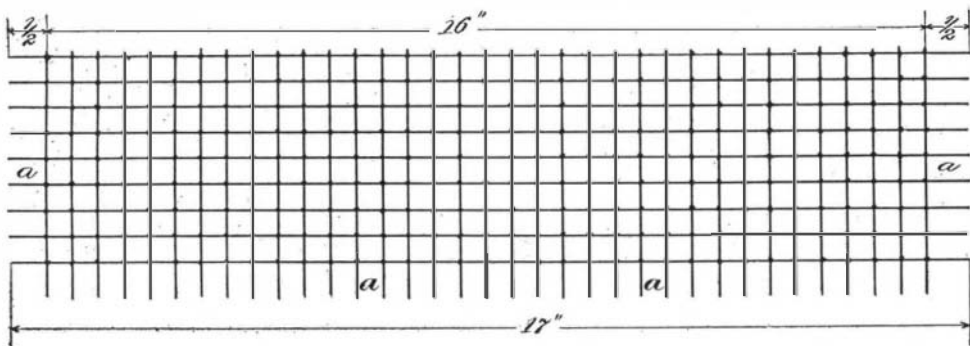

Fig. 1.—SIDE AND BOTTOM PIECE OF WIRE LATH FOR FRAME OF ROUND JAR.

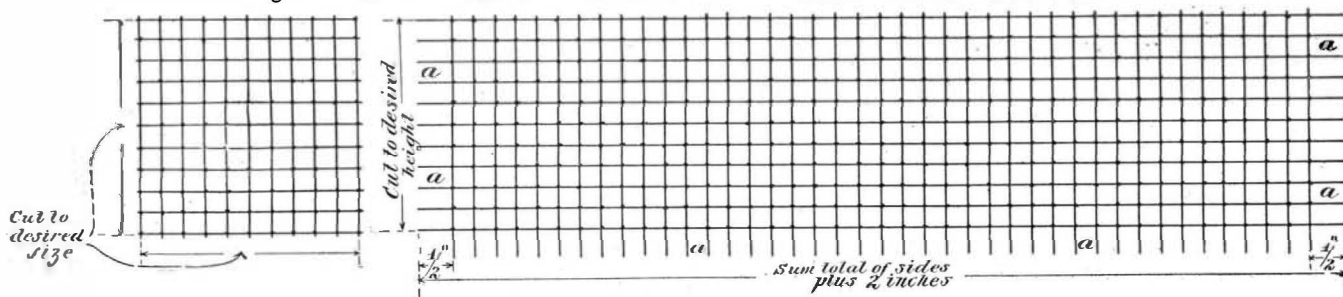

Fig. 3.—SIDE AND BOTTOM PIECES FOR RECTANGULAR JAR.

more distinct marks. Now take the wire cutters and cut the wire directly at the marks, and you will have the bottom of the frame complete.

The diameter of the bottom being 5 inches, the piece necessary for the sides of the frame will have to be three times this length, or 15 inches. Make it 17 inches long, thus allowing 1 inch for lap, and ½ inch of surplus wire on each end, as indicated at a—a. The height of the finished form is to be four inches. Cut the wire lath to 4½ inches, leaving a series of wire strands half an inch long at the bottom as indicated. Now take this piece which has been prepared for the sides and coax it into a circle by placing a straight edge (a piece of wood or metal having straight edges) successively along each of the meshes and pulling up on the free end of the wire lath as indicated in Fig. 2. After the piece is fairly well formed, lap the ends over, thus forming the circle, and secure them firmly to the main body of the sides by turning the free ends of the wire around the strands of the wire mesh, using the nippers to clinch them tightly. After having completed the side the bottom is placed in position, and the half-inch lengths of wire left at the bottom of the sides are used to wrap around the bottom and secure it in place. It is not essential to have this frame absolutely round or true, as it is used merely as a surface on which to build up the cement. The cement when once in place can be trued up by methods which will be explained in future articles. The square frame which is also illustrated is made in a similar manner. Care must be taken, however, to get the corner lines perpendicular to the base, for if this is not done it will cause trouble later on when truing up the sides.

In cutting the wire lath for the sides, do not forget to make it at least two inches longer than the sum total of the four sides. This will allow plenty for

the lap and for the wire strands which are to be used for securing the ends in place. Of course, one need not confine himself to round and square forms, as innumerable sizes and shapes of frames can be made up, such as octagons, hexagons, etc., as well as forms for vases with gracefully curved outlines.

The next article in this series will treat of the method of applying the cement mortar and the forming of the finished pottery.

(To be continued.)

A SIMPLE MEDICAL COIL.

BY FREDERICK E. WARD.

Doubtless there are many persons who would like to make an induction coil for medical use, but are deterred from so doing by the belief that the work is too difficult for any one but a skilled mechanic to undertake. This is a great mistake, however, as it is quite possible for almost anybody to make a coil that will give good results at a cost of but a few cents, and with the use of only the most ordinary tools.

For the core there may be used an iron bolt about three inches long and three-eighths of an inch in diameter, as shown at A in the accompanying drawing. It is a good plan to soften the bolt by heating it red hot in a fire and allowing it to cool slowly. Make two thin wooden washers about an inch and a quarter in diameter, and glue them on the bolt to form a spool as shown at B, and cover the iron between the heads with a wrapping of two layers of paper glued on. The nut shown is not necessary, but makes a neat finish.

The first part of the winding, or primary coil, requires about half an ounce of No. 20 or No. 22 double cotton-covered magnet wire. Pass the end of the wire through a small hole in one of the heads, and wind on a smooth layer of the wire like thread on a spool. When the opposite head is reached wind a second layer of wire over the first one back to the place of beginning. Cut off the wire and pass the end through a second hole in the head near the first one, as shown at D. The excess of wire will be useful for connections.

The next part of the winding, or secondary coil, requires an ounce or two of No. 32 single cotton-covered magnet wire. Finer wire gives more powerful results because of the greater number of turns for a given weight, but it is rather delicate to handle. Before winding on any of this wire, glue on a wrapping of two or three layers of paper over the primary coil, to keep the two coils entirely separate. The secondary wire need not be wound in layers, though care is required to avoid injuring the insulation or breaking the wire by pulling it too tight. The two ends may be left projecting, as shown at H, for connection to two handles or electrodes, and the coil may be protected by a final wrapping of paper, as shown at C.

One pole of a dry battery E is connected to the tang of a large file F, and the other to one of the primary terminals D. The remaining primary ter-

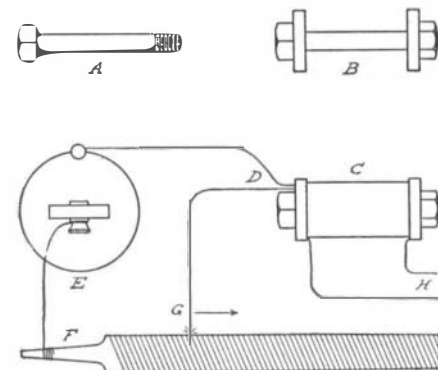

A SIMPLE MEDICAL COIL.

minal G is then lightly dragged along the surface of the file, thus making and breaking the circuit in rapid succession as the wire passes over the teeth. If the shocks received from the handles are too strong, use a longer piece of wire at G; if too weak, add another dry battery in series, or put more wire on the secondary.