

a little practice this can be accomplished quickly and neatly. Now hold the sharp edges of the opening in the globe in the flame until soft, and quickly, with the tang of the file, smooth down and turn out the edge into a sort of a flange, taking care to keep the hole round. When the globe has cooled, hold it with a cloth and place the large end in the flame until it softens. Then press it down on a dry board until the bottom is sufficiently flattened to make the flask "steady on its legs." The flask is now finished with the exception of annealing. When several of the flasks are finished, they should be placed in a vessel of brine and gradually heated up to the boiling point, and then set aside to cool. They can now be used in the same way as the ordinary commercial flask.

ROTAGONS.

BY E. F. FABODY, JR.

There is a class of geometrical figures possessing peculiarities which possibly have not been investigated or published before. For the sake of a title, and owing to the relation these figures bear both to circle and polygon, let us arbitrarily name them "rotagons." A rotagon is a plane figure whose perimeter is composed of an odd number of circular arcs such that each point where two arcs meet is the center from which the opposite arc may be described.

Referring to diagram No. 1, the figures A, B, C, and D show four out of an infinite number of forms which the rotagon may take. It may be observed that these figures have the same width in all directions, that the sum of the arcs equals a semi-circle, that the sum of the points of the inscribed star is therefore 180 degrees, or in other words, the dotted line and arcs represent the overlapping sectors of a semi-circle, and that these dotted lines may be conceived as link work whose limit of motion is reached in the figure A. When inscribed in a square or rhomb, rotagons may be conceived as turning around while remaining at all times in contact with the four sides. When regular in form, they may turn in any regular polygon

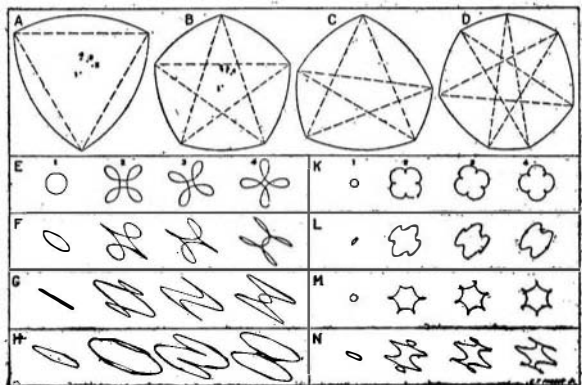

Fig. 1.—FIGURES PRODUCED BY ROTAGONS OF VARIOUS FORMS.

the number of whose sides is one more or one less than the number of arcs, and they will maintain contact with all of the sides. It follows that the same motion is possible within any combination of three or more sides of the polygon, which, if produced, will close.

The motion is complex and the complete orbit of any given point consists of a number of elements (*glissettes*) which may be either elliptical, circular, or straight. These orbits, by reason of their composite nature, are of curious and even fantastic forms. Some idea of their endless variety may be gained from the accompanying diagrams, which were developed graphically by means of cardboard models. As the figure A turns in a square (see Fig. 1), the points 1, 2, 3, 4, describe the paths shown in section E. Sections F, G, and H contain the orbits of the same points as the figure turns in rhombs, whose minor angles are respectively 75, 60, and 45 degrees. Sections K,

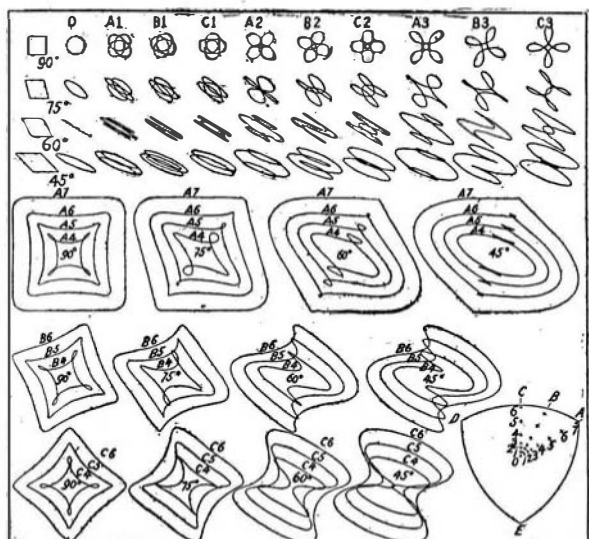
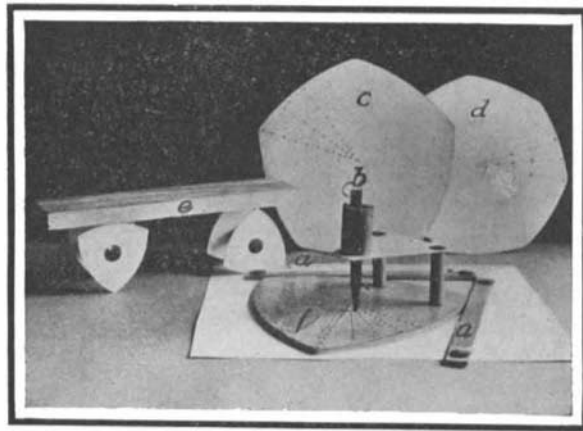

Fig. 2.—MOTIONS OF A TRIANGULAR ROTAGON IN A SQUARE AND RHOMBS OF VARIOUS ANGLES.

L, M, and N show the corresponding curves for points 1, 2, 3, 4, in the figure B. When A revolves once in a square, its center of gravity at point 1 makes three revolutions in an opposite direction in an orbit composed of four elliptical arcs. Regular rotagons produce symmetrical orbits, but irregular figures such as C and D produce unsymmetrical orbits. That such



ROTAGON APPARATUS FOR PRODUCING GEOMETRICAL FIGURES.

complex and intricate motions are possible in a single moving part under such simple conditions of operation, seems almost incredible until one has made the experiment. There is a singular grace and beauty in some of the curves, which suggest possible adaptation in the field of decorative design.

Diagram No. 2 shows more fully the motion of the triangular rotagon. Twenty points are taken in the figure DAE, the point O being at the center and points 1, 2, 3, etc., being on the three axes A, B, and C. Each point and its corresponding orbit is indicated by the axis letter and the number of the point on that axis. The orbits marked 90 degrees are described by these points when the rotagon moves in a square, and the other orbits are developed by turning the figure in rhombs, whose minor angles are 75, 60, and 45 degrees, as indicated.

In the illustration herewith, the model *f* is shown ready for operation. The weighted pencil *b* is inserted in one of the holes in the cardboard and the model is turned around by hand and at the same time kept in contact with the guides *aa*, which may be set at any angle. As the motion is determined by two contact points, the other two sides are unnecessary. The model used is about six inches in diameter, and from the orbits drawn by the pencil, free-hand ink tracings were made in order to facilitate reproduction in the accompanying cuts. This accounts for some roughness in the curve, which does not exist in the pencil drawings. Five-sided and seven-sided models (*c* and *d*) are shown in the illustration, and also a piece of wood *e* resting on "three-cornered rollers." When set in motion *e* travels in a straight line, exactly as if supported on cylinders, while the motion of the supports is alternately circular and cycloidal. The same motion would follow with any other form of the rotagon. To most persons it will come as a surprise to realize that a cylinder is not the only form of roller which will impart straight-line motion to a supported body.

The rotagon may possess little interest for the mathematician and may be without value in the realm of mechanics, but its properties are so unique and the infinite variety of its fixed motions is so startling that it becomes worthy of investigation, even if regarded only as a scientific toy.

NOVEL HEAT MOTOR.

BY R. V. HEUSER.

Owing to the fact that water in liquid form is nearly incompressible, it cannot be used to perform a cycle of operations such as take place in the steam engine. Theoretically, however, any substance having a temperature above its surroundings is capable of serving as a power generator. Disregarding the possibility of thermo-electric conversion of energy, useful mechanical work can be derived through the expansion of vapors of volatile substances. Many liquids are known to pass into vapor under a feeble heat, such as, for instance, the sun's rays.

If other media than water are used as heat carriers, it becomes indispensable to recover the original liquid by means of condensation for economic reasons.

A simple apparatus, which can be made by the Handy Man, will demonstrate that a very small degree of heat is sufficient for performing light mechanical work.

A disk *E*, mounted on shaft *D*, serves as support for six compartments, *B*₁, *B*₂, . . . *B*₆, concentrically arranged about *D*. These as well as the disk can be made of tin soldered together. Two opposite chambers, for instance, *B*₁ and *B*₆, are connected by a small brass tube *C*, bent outward at the center to clear the shaft

D, and projecting through the chambers nearly to the outer cylindrical wall. Two uprights, *F*₁ and *F*₂, support the wheel at a proper distance over a small flame *A* or over a basin filled with hot water. One of each pair of chambers is filled with ether or acetone, while the other contains only the vapor of the liquid in an expanded state, but no air at all. The liquid is introduced into the chambers through small holes, and after the air has been blown out (by heating this

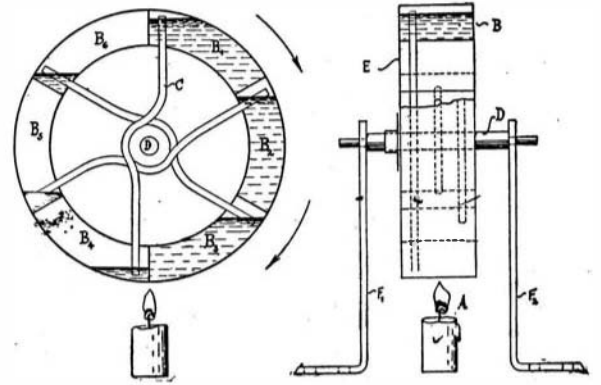

A SIMPLE HEAT MOTOR.

liquid to the boiling point) each hole is sealed with a drop of solder.

Evidently, when one chamber passes through the hot zone, the liquid vaporizes and passes through the tube to the opposite chamber where it condenses. Thus the center of gravity is constantly changed, causing the wheel to revolve.

ANOTHER JOINT FOR HANDY MAN'S WORK BENCH.

BY CHARLES LURCOTT.

The joints of a work bench are sure to work loose in time, and it is important that they be constructed in such a way that they may be tightened from time to time. No such provision was made in the bench described in the SCIENTIFIC AMERICAN for December 19th, 1908, or in the joint described in the issue of February 6th, 1909, and hence the following suggestion

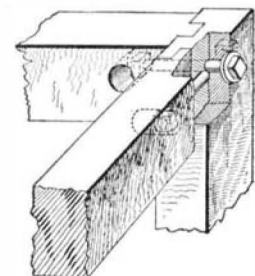

A JOINT FOR THE WORK BENCH.

may prove of value. The construction is one that the writer has used with perfect satisfaction for years. The frame of the bench is made of 2 x 3 inch sticks. Sockets are cut in two adjoining faces of the post to receive the tongues formed on the horizontal sticks of the frame. The sockets are made deeper than the tongues, so as to permit of adjustment. A hole is bored through the post and endwise into one of the horizontal sticks through the tongue. A bolt is fitted into this bore and is screwed into a nut which is introduced into the stick through a transverse hole. In the same way the other stick is secured to the post, care being taken to have the second bolt hole at a different level so that it will clear the first one. The bolts can be drawn up very tightly, so as to make a firm joint. When the joint works loose it can be tightened up with a wrench in a moment's time.

A REMEDY FOR LOOSE WOOD SCREWS.

BY G. W. NAYLOR.

A convenient method of making a loose screw hold is illustrated herewith. Take a soft piece of copper wire, and wind it around the threads of the screw as

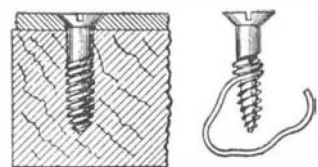

A REMEDY FOR LOOSE WOOD SCREWS.

shown, thus in effect increasing the diameter of the threaded part. This will save plugging or using a larger screw.

HARDENING COPPER.

BY H. D. CHAPMAN.

Copper treated as follows becomes harder and tougher than commercial hard copper: Take 2 pounds of alum and 8 ounces of arsenic, and mix well. Forty pounds of copper is to be used with this quantity of alum and arsenic. When the copper is thoroughly melted the alum and arsenic are poured in the crucible, and mixed well with the melted copper. The copper is then poured, and allowed to cool gradually.