

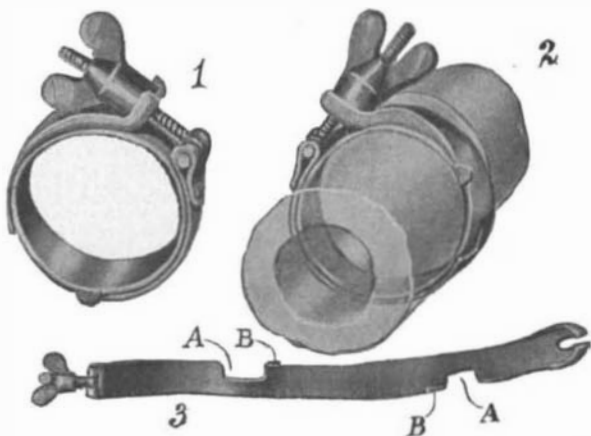

AN IMPROVED HOSE COUPLING.

It is absolutely necessary that the pipe connections between the radiator and pump of an automobile be kept perfectly tight. Otherwise, whatever leakage exists will result in the introduction of air in the cool-



IMPROVED HOSE COUPLING.

ing system which may cause air locks and so complete the stoppage of the flow. The ordinary hose couplings do not completely encircle the hose. When they are tightened up they compress the under side of the hose, but dilate the upper part immediately under the adjusting screw. Hence, unless a very tight fit of hose is provided leakage will take place under the dilated part. To overcome this difficulty, the hose coupling illustrated in the accompanying engraving has been designed. It consists of a strip of brass which passes twice around the hose, thus completely encircling it even under the adjusting screw. In order to permit the two layers of the coupling to lie one on top of the other, the brass strip is cut away at the points A, Fig. 3, where one part passes through the other. Lugs B adjacent to these strips serve to keep the two layers of the coupling over each other. When this strip is applied to the hose it compresses it with an equal pressure at every point, overcoming the liability of leakage, and for this reason it is not necessary to have the hose fit so tightly that it can only with difficulty be forced on. The inventor of the device is Mr. Thomas B. Reid, of 132 Nassau Street, New York.

A NOVEL FRYING DEVICE.

Pictured in the accompanying engraving is a cooking utensil adapted to take the place of the common frying pan and which will prevent grease from being splattered over the kitchen floor. The utensil is formed with an outer pan, A, provided with lateral handles B and vertical handles C. Adapted to be placed within the pan A is a second pan D, which is formed with a bottom of wire netting. Hinged to the pan D at opposite sides are two handles E each provided with a cover section F of wire netting. The cover sections are of such form as to completely close over the top of the pan D. Additional inner bottoms of wire net-

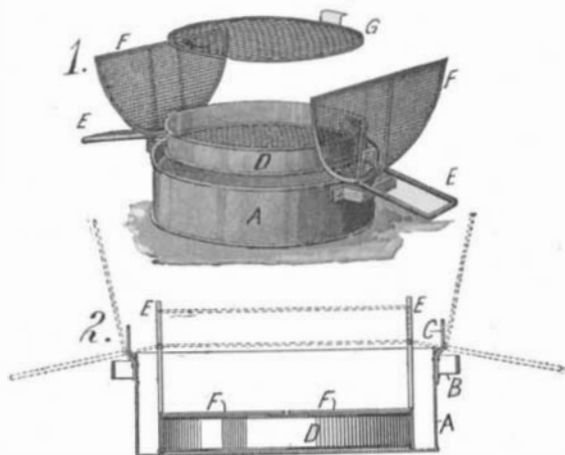

FRYING DEVICE.

ting are provided as indicated at G. In use the lard or butter is placed in the pan A and set on the stove. The food may be placed in the pan D, after which the covers F are closed over the pan, which is then completely submerged in the boiling lard. Whenever desired the pan D may be lifted bodily out of the pan A by means of the handles E, or it may be raised out of the fat and supported on the pan A by swinging the handles E outward and hooking them over the handles C. The grease will then drain off through wire netting bottom. It will be understood that as the covers are adapted to hold the food below the hot

fat, it will be unnecessary to turn it and the food will be just as brown on top as on the under side. Whenever desired the inner bottom G may be used, which will permit the cook to remove the contents of the fryer without lifting the pan D off the pan A. A patent on this improved frying device has been secured by Mr. Jacob Renner, of Rockville City, Iowa, P. O. Box 238.

AN IMPROVED RAT TRAP.

A novel form of rat trap has recently been devised which is provided with dark runways leading to a bait room in which are trap-doors adapted to open under the weight of the rat and precipitate it in a receptacle containing water or an acid that will quickly kill it. The inventor finds that rats do not care to frequent places which are exposed to light, and for this reason he has provided darkened runways of a special form which are attractive places for rats to collect in even when there is no bait in the bait room. Furthermore, the arrangement is such that when the rat falls into the receptacle the trap doors swing back to their original position and prevent any noise being heard by other rats that might be attracted to the trap. As illustrated in the accompanying engraving, the trap comprises a receptacle A with converging sides over which is placed a hood B, the latter being spaced from the receptacle to form the runways. The side walls of the receptacle A are provided with steps C which will permit the rats to climb to the top of the trap and enter the bait room by way of the openings D. The trap doors in this room are indicated at E. Above them is a series of hooks F on which the bait is hung. Each door E, at its inner end is further provided with a bait receptacle G. The interior of the receptacle A is filled with the water or acid which is to destroy the rats that are caught. At the bottom of the receptacle is a slideway H which may be opened to permit of emptying the receptacle of the liquid and of the rats

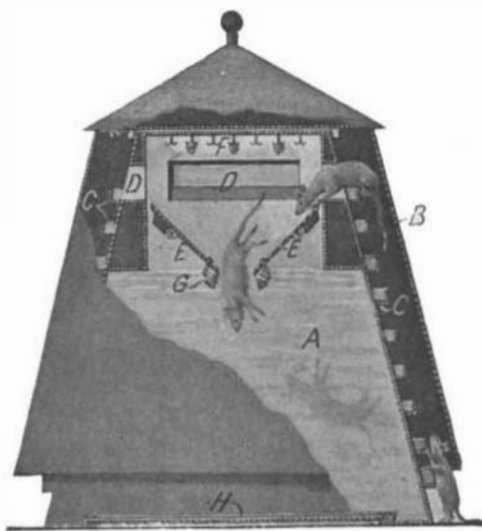

IMPROVED RAT TRAP.

that have been caught. The operation of the trap is self-evident. Mr. M. Kaiser, of 2816 Bryant Avenue, San Francisco, Cal., has secured a patent on this trap.

A NEW RAILROAD SPIKE.

With a view to preventing a spike from being bent outward in the tie so that the head slips off the base of the rail, spikes have been invented which are provided with a spur at the rear side adapted to act as a brace for the main body of the spike. However, owing to the enormous pressure applied to the tie as the train passes over the rails, the tie is apt to be slightly bent between the shank and the spur, working the spur loose, and in this manner tending to loosen the main spike. Furthermore, in spikes of this character the shearing effect is resisted almost entirely by the main spike and a slight bending of the spike causes a movement of the spur with respect to the body of the spike and a loosening of the spur. In order to overcome these difficulties a new form of spike has been invented which we illustrate herewith and which consists of two separate shanks A and B connected to the same head D. Furthermore, the bridge C that connects the two shanks is arranged to cut into the wood. The head is of such form that the spike may readily be withdrawn whenever desired. It will be observed that the shank adjacent to the rail is longer than the other one and that each shank terminates in a chisel-cutting edge of such form as to facilitate the driving of the spike into the tie. The bridge C connecting the shanks is formed with a cutting edge adapted to sink into the wood. Lateral thrust on the spike is resisted not only by the area of both shanks, but also by that of the bridge portion C. The substantially parallel sides of each shank render the device less liable to work loose than if it were tapered throughout its length. Mr. George K. Hoff, 7800 Frankford Avenue, Philadelphia, Pa., has been granted a patent on this improved spike,

A SIMPLE DRAWER STOP.
The invention illustrated herewith consists of a stop of very simple form adapted to be used in connection with the drawers of tables, desks, cabinets, and the like. The stop may readily be applied without the use of any special tool and without involving any changes in the construction of the drawer or adjacent parts. The stop prevents the drawer from being accidentally pulled entirely out of the table or desk; and

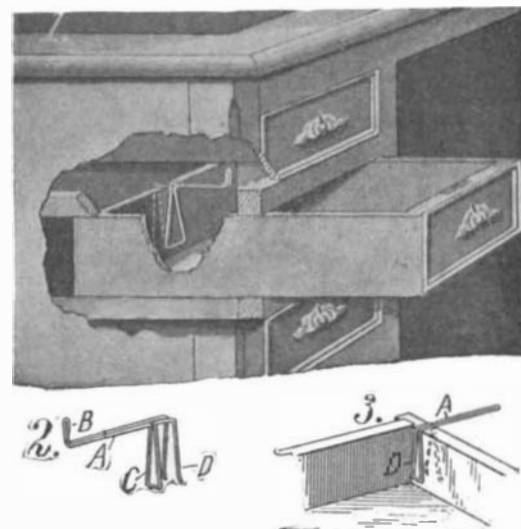

A SIMPLE DRAWER STOP.

furthermore, prevents papers or other contents of the drawer from slipping out at the rear. The device is formed of a single piece of wire so bent as to frictionally engage with and grip the upper edge of the rear wall of the drawer, and projecting upward sufficiently to strike the cross cleat or bar of the desk which lies directly above the opening into which the drawer extends. As shown in Fig. 2, the wire is bent double and comprises a body portion A, and an upwardly projecting part B. The wire on one side is bent to form a downwardly-extending jaw C, while the ends of the wire are bent down to form the jaws D. The edge of the drawer is gripped between the jaws C and D, while the part B is adapted to engage the stop bar. In the case of a flat top table in which there is no cleat or stop bar above the drawer, the drawer stop may be secured to the side of the drawer. In this case the modified form shown in Fig. 3 is preferred, as it has no upwardly-projecting part B. The body A of the drawer stop assists in holding down the contents of the drawer at the rear end thereof. Mr. William C. Heaney, of 802 Wells Fargo Building, Portland, Ore., has patented this drawer stop.

Helium in Rocks.

R. J. Strutt has found in numerous rocks helium in quantities which bear definite relations to the proportion of radio-active ingredients. He inferred that helium, being the final product of the radio-active transformation, must be present in quantity proportional to the age of the rock. In order to test this theory Strutt selected for examination a series of similar materials of very different ages and containing radio-active ingredients, namely, the phosphatic concretions derived from bone, which are found in many Pliocene and older strata. All of this material was found to possess much stronger radio-activity

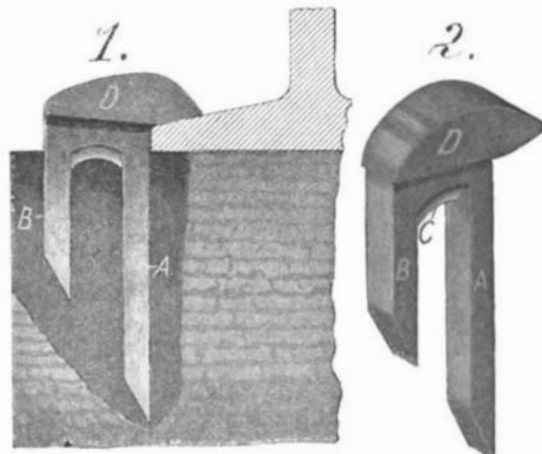

RAILROAD SPIKE.

than is exhibited by ordinary rocks, and all of it yielded more or less helium, and uranium. From the proportion between the helium and the uranium Strutt estimated the time required for the accumulation of the former, or in other words, the age of the stratum. This age was found to be 225,000 years for the English Pliocene or late Tertiary, 3,080,000 years for the upper green sand of the Cretaceous period, 3,950,000 years for the lower green sand, and 141,000,000 years for the hematite which covers the limestone of the Carboniferous. Of course, these figures, as Strutt observes, are only provisional estimates.