

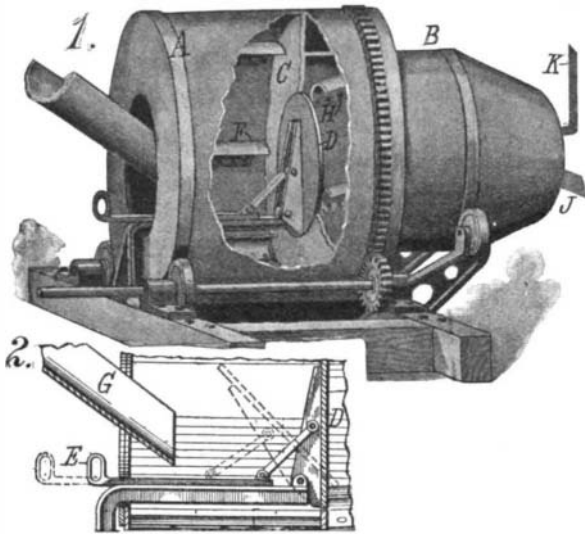

CONCRETE MIXING MACHINE.

In the ordinary concrete mixers, wet cement is liable to collect on the inside of the mixing drum. Unless this is frequently scraped off, the caking of



CONCRETE MIXING MACHINE.

the cement has the effect of contracting the capacity of the mixer, rendering it less efficient in operation, and causing some of the mixtures to be too poor in cement, while others contain a higher percentage of cement than desired, owing to the occasional breaking loose of a cake of the material. In the machine illustrated herewith, the aggregates are mixed dry, and during this mixing are widely scattered. But thereafter they are placed in a second drum, where the wetting takes place, and here they are confined as much as possible, so that the moisture is quickly and uniformly distributed. The dry mixing chamber of the machine is indicated at A, while the wet chamber, which is partly conical in form, is shown at B. In order to increase the strength of the construction, the chamber B is partly telescoped within the chamber A. A partition C separates the two chambers, and in this partition is a hinged gate D, connected by a link to an operating lever E. The drum A is formed with the usual gear ring, engaging a driving pinion, and is supported on rollers, so that it may be rotated by operating the pinion. Within the drum A is a series of buckets F, which pick up the material as it is introduced through the chute G, and thoroughly mix it. When the material has been sufficiently mixed, the gate D is lowered to the position indicated by dotted lines, when it acts as a chute to deliver the material into the second drum B. The latter is also formed with buckets which pick up the material and thoroughly mix it before it is delivered through the chute J. Water is introduced into this chamber through the pipe K. This cement mixer has been patented by Mr. A. G. Olsen, of Elkhorn, Wis.

ENGINE ALINER.

An improved device for lining up engines has recently been invented, which possesses a number of advantages over the ordinary device. It consists of two circular plates A and B, the plate B being formed with a flange in which recesses are cut to receive three radial members. These radial members are quite similar to each other, and each is formed with two oppositely-disposed parallel bars, one of which is provided with teeth adapted to engage a spur pinion mounted centrally in the disks A and B. By rotating this pinion, all three of the radial

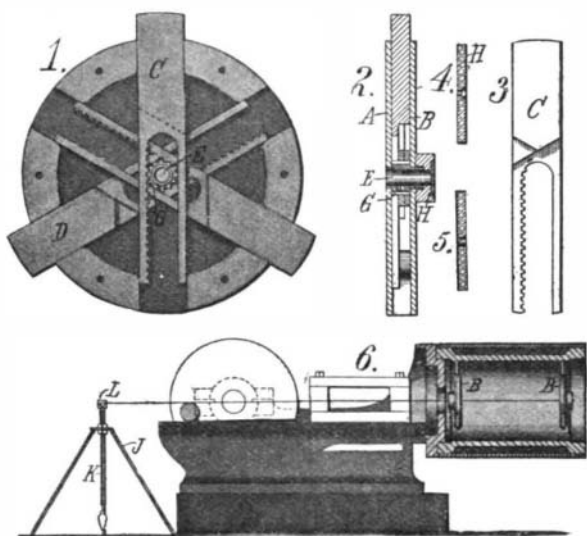

ENGINE ALINER.

members may be moved inward uniformly to center the device in the engine cylinder. A central opening is formed in the pinion, and this is covered by a glass plate H, in which is a central aperture. Two centering devices are commonly used when alining the engine, in one of which the glass disk is formed with an aperture such as shown in Fig. 5, while the glass disk of the other has a countersunk aperture, such as indicated in Fig. 4, to receive the knot of a cord. One of the figures shows how the apparatus is used. The cord knotted in one of the centering devices passes through the second centering device, and thence over a support L to a plumb bob, which holds it taut. The support L consists of a horizontal screw, which passes through the head of the vertical screw K, mounted in a tripod J. By operating these screws, the outer end of the cord may be adjusted horizontally or vertically, so that it will not touch the edges of the aperture in the glass of the second centering device. As the centering devices are provided with glass plates, the operator can look through them, and more readily direct the adjusting of the cord. The crankshaft is then adjusted to such a position that the cord crosses the wristpin half between the ends of the latter and across the center of the crankshaft. With the crankshaft supported in this position, the bearings may be rebabbitted, or otherwise adjusted to properly support the shaft. Mr. Oliver Gibbons, of Lookout, Cal., has been granted a patent on this engine aliner.

ADJUSTABLE HEAD FOR PIANO HAMMERS.

The piano hammer, which is illustrated in the accompanying engraving, is provided with a head, on which the felt strips are adjustable. The head of the hammer is resiliently supported on the shank, so as to permit of a quicker rebound than in the ordinary hammer. The hammer is formed with the usual back stop A and butt B, with a shank which supports the head D. The base E is mounted on the end of the shank and thence a pair of wire arms extend upward to a pair of blocks F and G, which are thus

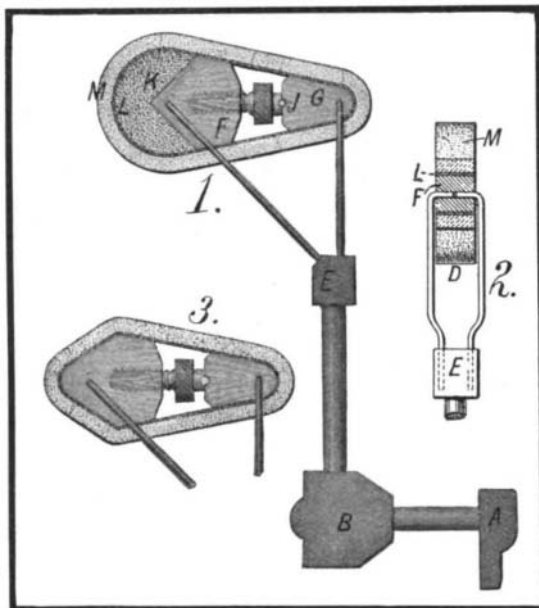

ADJUSTABLE HEAD FOR PIANO HAMMERS.

resiliently supported by the shank. Between these blocks a spreading screw is mounted, which is provided with a pin J, adapted to engage a depression in the block G to prevent the screw from turning after it has been set at the desired adjustment. The block F is formed with a V-shaped end over which a filler K of felt, or suitable material is placed. Around the filler and the blocks is an endless felt strip preferably formed of an inner part L and an outer part M. By turning the screw the tension of the felt may be adjusted to any desired degree. When it is desirable to shift the felt, the screw is turned to loosen the tension, and it may then be moved to bring a fresh surface to the striking position. The wire members which support the blocks are bent inward at their upper end to engage perforations in blocks so that when it is desired to remove the head they can be made to release the blocks by merely spreading them apart. Fig. 3 shows a slightly modified form of the adjustable head. The inventor of this piano hammer is Mr. John W. E. Laker, Box 103, Victoria, B. C., Canada.

APPARATUS FOR TREATING RUBBER.

In preparing crude rubber from the juice of the rubber tree, the usual method is to dip a stick into the juice, and then hold it in a smudge, so that the smoke will coagulate the rubber in a thin layer on the stick. Layer upon layer is thus formed, until a large mass of the crude rubber is obtained. A machine for performing this work has recently been invented. The machine comprises a drum A, open at each end, but formed with flanges to retain the juice of the rubber tree when placed therein. The drum is formed with an

axle B, on which is a crank to permit of rotating it during the process of coagulating the rubber. The drum is mounted within a smoke chamber C, being supported on a pivot rod D, that enters a hollow portion of the axle of the drum. The axle at the opposite end of the drum passes through a cap, which closes a large opening in one side of the smoke box. Below the smoke chamber C is a fire chamber E of frusto-conical form. The two chambers are separated by a screen, which supports a mass of pebbles and broken stone. The purpose of this screen is to prevent soot

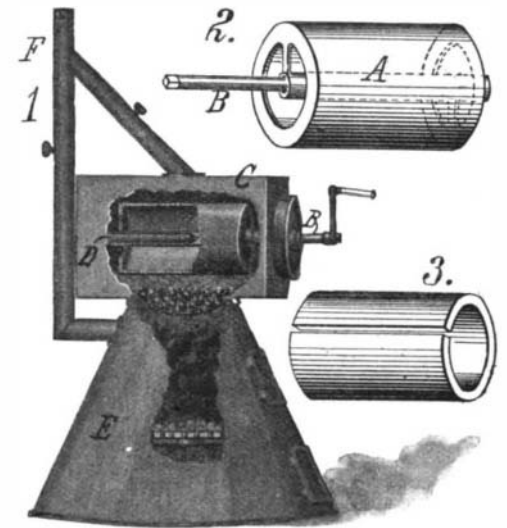

APPARATUS FOR TREATING RUBBER.

or ashes from passing upward and lodging in the rubber. A smoke pipe F is formed with two branches, one connecting with the smoke chamber C, and the other with the fire chamber E. In operation the drum is partly withdrawn from the smoke chamber, while its inner end is supported on the pivot rod D, and a quantity of the juice is poured into it. The drum is then moved back, and the smoke chamber is closed. Now, on operating the crank, the drum is revolved, and a thin layer is formed on the inner side of the drum. This layer gradually grows until the entire mass of rubber is coagulated. The dampers are then turned, to permit the smoke to pass up the chimney without going through the smoke chamber. The drum A can now be removed, and the mass of rubber taken out of the drum by cutting it lengthwise. The rubber thus formed will have the shape shown in Fig. 3. Mr. Enrique Molina, of 131 East 63rd Street, New York, is the inventor of this apparatus for treating rubber.

VALVE FOR FLUSH TANKS.

The valve which is illustrated herewith contains no gaskets or packing in its working parts, and hence is less liable to get out of order than the ordinary valve. The valve casing as indicated in the illustration, is fastened on the bottom B of the flush tank. The valve is formed with a stem C, which is adapted to slide vertically in the casing. Passing through an opening in the upper end of the stem is the float arm D, which is hinged to the casing and is provided at its opposite end with the customary float. The lower end of the stem is formed with a conical plug, constituting the valve proper, which is adapted to fit the conical valve seat, as indicated in Fig. 1. There are two pairs of openings, E and G, leading into a hollow portion of the valve stem. The upper pair E is adapted to register with a pair of ports F in the valve casing when the valve is depressed or opened, as shown in Fig. 2. When in this position, the water runs from the supply pipe, past the conical plug, through the ports G, into the hollow portion of the valve stem, and thence by way of openings E and ports F into the flush tank. It will be observed that the ports F are downwardly inclined, thus directing the streams of water downward, and preventing spattering over the sides of the tank. When the float arm D rises, the plug is seated, cutting off the supply of water. The

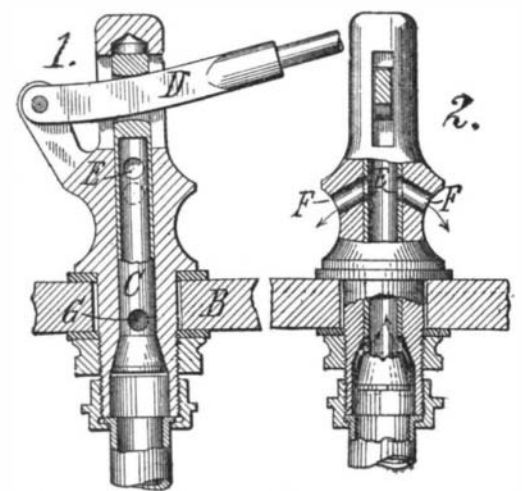

VALVE FOR FLUSH TANKS.