

ern bank is 262½ feet long between sills by 52½ feet wide, fitted with gates 40 feet deep and a swing bridge. On the upstream side the foundations comprise puddle clay topped with limestone pitching 65 feet 7 inches wide; while on the downstream side, to avoid the severe scouring of the water pouring through the sluices, there is a protective apron composed of limestone pitching carried to a distance of 131¼ feet from the toe of the dam. The floor is built up of concrete, 3 feet 3 inches thick, with a superimposed layer of granite rubble masonry 6 feet 6 inches thick. The total cost of the barrage has been approximately \$5,000,000 and it was formally opened by the Khedive on February 9th. The provision of this dam will insure a plentiful supply of water for irrigation through a great tract of fertile land, even in the lowest floods, and will remove all apprehensions regarding the safety of the crops within its area for all time. The chief engineer responsible for the works was Mr. Murdoch Macdonald, the Director General of Reservoirs for the Egyptian government.

IMPROVED VEHICLE WRENCH.

Pictured in the accompanying engraving is a wrench particularly adapted for unscrewing the nuts of carriage and wagon axles. The wrench differs from the ordinary in that it securely holds the nut

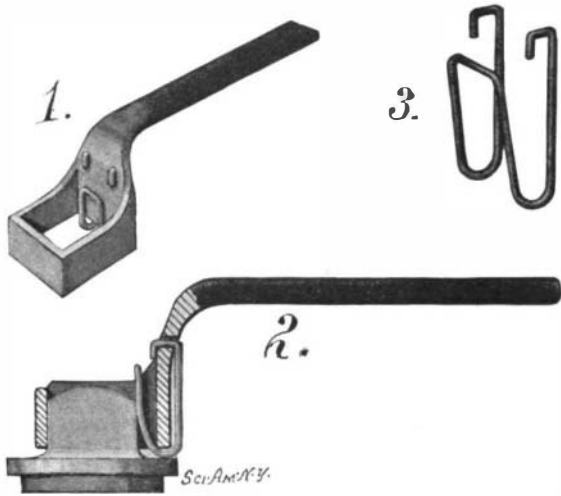

IMPROVED VEHICLE WRENCH.

in place, permitting of conveniently starting the nut when screwing it on the axle, and preventing it from falling and being lost when it is removed from the axle. The general form of the wrench is similar to the ordinary, consisting of the usual square socket with an extension at one side which serves as a handle. Fitted in the socket is a spring, the general form of which is indicated in Fig. 3. It will be observed that the spring is bent at its center, and then doubled, so as to provide a portion which extends into the socket and another portion which passes along the outside. The outer portion terminates in a pair of hooks which pass through openings in the wrench just below the handle, and serve to hold the spring firmly in place. When using a wrench of this sort the operator may keep his hands clean, for he does not have to touch the nut. The wrench clings to the nut after it has been removed, and there is no danger of its becoming soiled by falling to the ground. The inventor of this improved vehicle wrench is Mr. Carroll J. Atkins, Cando, N. D.

DEVICE FOR OPERATING WINDOW SHUTTER.

In cold weather, or when a rain storm suddenly comes up and it is desirable to close the window shutters, it is rather unpleasant to have to expose oneself to the elements by opening the window and reaching out for the shutter arm or catch. The accompanying illustration shows one method of overcoming this ob-

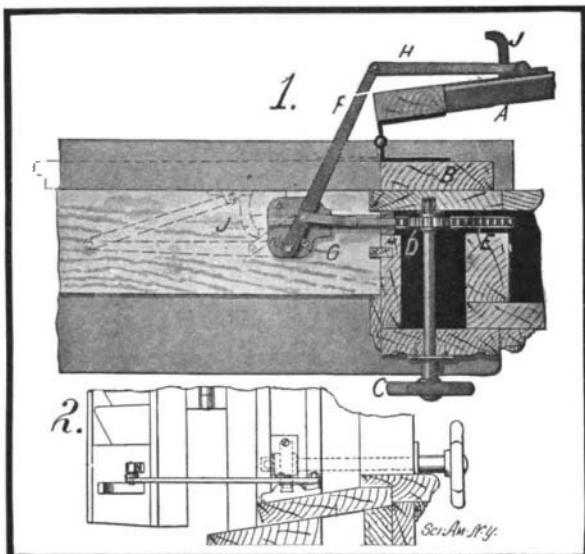

DEVICE FOR OPERATING WINDOW SHUTTER.

jectionable task by operating the shutter from within the room. A sectional view, in plan, of the mechanism used is shown in Fig. 1. The shutter *A* is hinged to the outer frame *B* of the window. Projecting through the inner side of the frame is a hand wheel *C*, mounted on a shaft which carries a pinion *D*. The latter engages a rack *E*, adapted to slide through the stile of the window frame. At its outer end this rack bar is connected by a link to a lever arm *F*. The lever arm is pivoted at one end to a plate *G* secured to the window sill, while at its opposite end it is connected by a link *H* to the shutter *A*. When the hand wheel *C* is turned in clockwise direction, the rack bar *E* is fed toward the left, causing the lever arm *F* to swing on its pivot, closing the shutter *A*. The end of the rack bar which slides in a track formed in the plate *G* engages a hook *J*, carried by the shutter *A* when the latter is closed, as shown by dotted lines in Fig. 1. This serves to lock the shutter in closed position. The inventor of this shutter-operating mechanism is Mr. August Weber, of Long Branch, N. J.

KETTLE STILL.

A simple apparatus for distilling water is illustrated herewith, which should prove quite valuable in districts where the water is so impure that it must be filtered and boiled before it can be used. The apparatus is in the form of a kettle, and, in fact, may be used as a kettle when it is not desired to use it as a still. The body of the kettle, which is indicated by the letter *A* in the engraving, is provided with a main spout *B* at one side, and a smaller spout *C* at the opposite side. The interior of the kettle is divided into two compartments by means of a partition *D*, and the spout *C* communicates with the upper compartment. The partition *D* is formed with a central tubular por-



KETTLE STILL.

tion, opening through the top of the kettle to permit of pouring water into the lower compartment. A bucket *E* is used with the kettle and is provided with a flanged portion at the bottom adapted to fit into the tubular portion of the partition *D*. Communication between the interior of the bucket *E* and the lower compartment of the kettle is had through an opening *G* surrounded by an upwardly-extending flange. Adapted to fit into the bucket *E*, or formed integrally therewith, is a second bucket *F* which is of such dimensions as to provide a narrow chamber between the two buckets. In use, the lower compartment of the kettle is filled with the water to be distilled, and as this water is brought to a boiling point over a fire, the steam generated passes into the bucket *E* and is condensed by coming into contact with the bucket *F*. The latter is filled with cold water so as to keep it cool and insure proper condensation of the steam. The condensed steam cannot flow back into the chamber *A*, owing to the flange surrounding the opening *G*, but it flows through a small pipe into the upper chamber of the kettle. Thence it may be poured out through the spout *C* when desired. It will be observed that the spout *B* is almost entirely cut off from communication with the body of the kettle *A*, except for a small aperture at the bottom, the object of this being to prevent the steam from escaping through the spout *B*. Mr. A. W. Blunden, of Sebastopol, Cal., has recently secured a patent on this kettle still.

A NOVEL ELECTRIC MOTOR.

Pictured in the accompanying engraving is an electric motor which is operated by an oscillating armature. The motor is formed with a C-shaped permanent magnet *A*. The oscillating armature is supported on a shaft *B* between the poles of the permanent magnet. The armature consists of four electromagnets numbered 1 to 4 in the illustration, and the polarity of

magnets 1 and 3 is of the same sign, but opposite to that of the magnets 2 and 4. By alternately changing the polarity of these electromagnets, a rocking motion of the armature is produced, owing to the action of its poles on those of the permanent magnet. The armature shaft *B* is formed with an arm *C*, connected by a pitman *D* to the revolving power shaft of the motor. The latter carries a flywheel at each end. Connected to the power shaft by means of a crank and link *E*, is a crank arm formed on the rock shaft *F*. The latter carries four disks *G* of insulating material, which are connected by means of rods *H* and *J*. Bearing against these rods are the contact springs *K* and *L*, and the

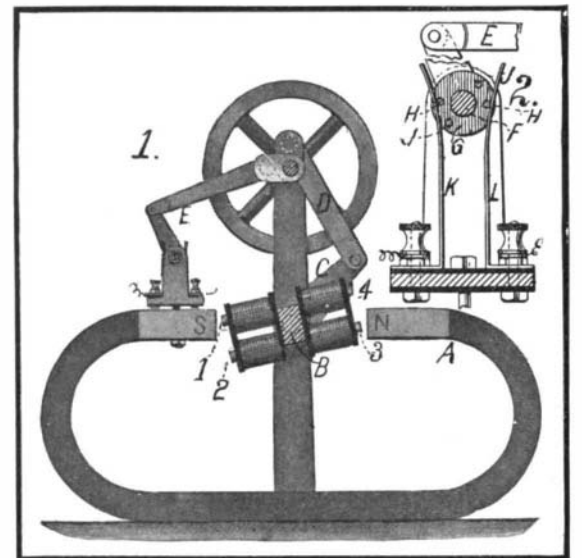

A NOVEL ELECTRIC MOTOR.

circuits are so arranged that as the shaft *F* is rocked back and forth by the rotation of the power shaft the current is alternated, thus alternating the polarity of the electromagnets. When starting the motor, it is merely necessary to rock the armature out of the neutral position, after which it will continue to rock and acting through arm *C* and pitman *D*, keep the power shaft in motion. Mr. Gustaf Seidel, of Saunderstown, R. I., is the inventor of this electric motor.

IMPROVED GARMENT HANGER.

One of the objections to the ordinary garment hanger is the fact that the arms are set at a fixed position which cannot be altered to suit different styles of garments, and the length of the arms cannot be adjusted to meet various requirements. The garment hanger which is illustrated herewith is designed to overcome these faults. The two arms *A* are formed of sheet metal and are reduced at one end where they are joined by a bolt or pivot *B*. The body of each arm is folded over, forming a flat sleeve adapted to receive an extension member *C*. The outer end of each member *C* is shaped to support the shoulder of the garment. At the under side of each arm *A* are a number of openings *D*, adapted to receive a projection *E* on the inner end of the extension member *C*. Thus, when the extension member is drawn out to the desired degree it will be held in place by engagement of the projection *E* with one of the apertures *D*. Each arm *A*, at the pivot end, is provided with an arcuate extension *G*. One of these arcs is provided with a number of projecting teeth which are adapted to be engaged by a single tooth on the other arc, to hold the two arms at the angle at which they are set. The hanger *F*, which is secured to the pivot bolt, is offset so that when the two arms are folded together it may be turned down against their edges (Fig. 2). The inventor of this garment hanger is Mr. Reginald C. Thomas, of 337 State Street, Brooklyn, N. Y.

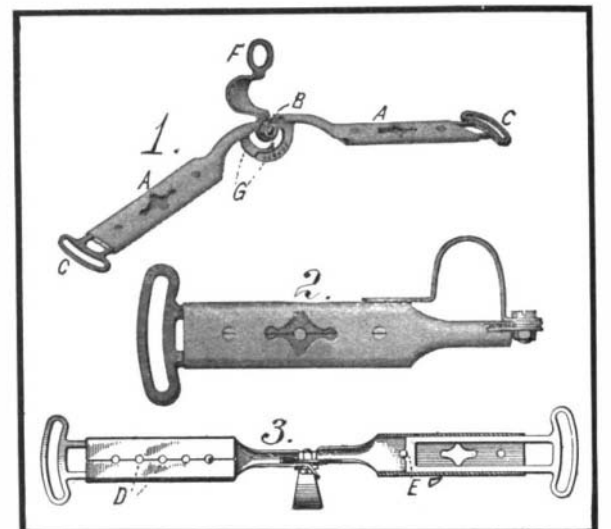

IMPROVED GARMENT HANGER.